

# REPAIR MANUAL 1999-2010

125/144/150/200

SX, SXS, MXC, EGS, EXC,  
EXC SIX DAYS, XC, XC-W

REPARATURANLEITUNG

MANUALE DI RIPARAZIONE

MANUEL DE REPARATION

MANUAL DE REPARACION



Art. NR.: 3.206.082-E

**KTM**

**PartShark.com**  
**877-999-5686**

**REPAIRMANUAL1999-2010**

125/144/150/200

SX, SXS, MXG, EGS, EXC, EXC SIX DAYS, XC, XC-W

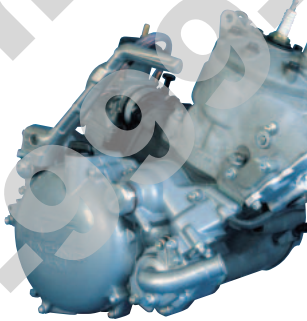

KTM Group Partner



**PartShark.com**  
**877-999-5686**



**1 SERVICE-INFORMATION**

---

**2 GENERAL INFORMATION**

---

**3 REMOVING AND REFITTING ENGINE**

---

**4 DISASSEMBLING THE ENGINE**

---

**5 SERVICING INDIVIDUAL COMPONENTS**

---

**6 ASSEMBLING THE ENGINE**

---

**7 ELECTRICAL**

---

**8 FUEL SYSTEM**

---

**9 TROUBLE SHOOTING**

---

**10 TECHNICAL SPECIFICATIONS**

---

**11 PERIODIC MAINTENANCE SCHEDULE**

---

**12 WIRING DIAGRAMS**

---

**13**

---

**14**

---

**15**

---

**16**

**PartShark.com**  
**877-999-5686**



**PartShark.com**  
**877-999-5686**

## EXPLANATION - UPDATING

<b>3.205.74-E</b>	<b>Repair Manual 125/200 SX, MXC, EXC</b> Basic version Model year 1999 (Engine number with first digit "9")	<b>3/1999</b>
<b>3.205.88-E</b>	<b>Updating of Rep.Manual 3.205.74-E</b> Model year 2000/2001 (2000: Engine number with first digit "0") (2001: Engine number with first digit "1")	<b>8/2000</b>
<b>3.210.27-E</b>	<b>Updating of Rep.Manual 3.205.74-E</b> Model year 2002 (Engine number with first digit "2")	<b>7/2001</b>
<b>3.206.005-E</b>	<b>Updating of Rep.Manual 3.205.74-E</b> Model year 2003 (Engine number with first digit "3")	<b>11/2002</b>
<b>3.206.017-E</b>	<b>Updating of Rep.Manual 3.205.74-E</b> Model year 2004 (Engine number with first digit "4")	<b>10/2003</b>
<b>3.206.021-E</b>	<b>Updating of Rep.Manual 3.205.74-E</b> Model year 2005 (Engine number with first digit "5")	<b>8/2004</b>
<b>3.206.031-E</b>	<b>Updating of Rep.Manual 3.205.74-E</b> Model year 2006 (Engine number with first digit "6")	<b>9/2005</b>
<b>3.206.050-E</b>	<b>Updating of Rep.Manual 3.205.74-E</b> Model year 2007/8 (Engine number with first digit "7" and "8")	<b>9/2007</b>
<b>3.206.062-E</b>	<b>Updating of Rep.Manual 3.205.74-E</b> Model year 2009/10 (Engine number with first digit "9" and "0")	<b>7/2009</b>

Modification / Updating:  
Technical Details, Technical Specifications,  
tightening torques, Periodic Maintenance Schedule

**PartShark.com**  
**877-999-5686**

## INTRODUCTION

This repair manual offers extensive repair-instructions and is an up-to-date version that describes the latest models of the series. However, the right to modifications in the interest of technical improvement is reserved without updating the current issue of this manual.

A description of general working procedures common in workshops has not been included. Safety rules common in the work shop have also not been listed. We take it for granted that the repairs are made by qualified professionally trained mechanics.

Read through the repair manual before beginning with the repair work.

**⚠ WARNING ⚠**  
**STRICT COMPLIANCE WITH THESE INSTRUCTIONS IS ESSENTIAL TO AVOID DANGER TO LIFE AND LIMB.**

**! CAUTION !**  
**NON-COMPLIANCE WITH THESE INSTRUCTIONS CAN LEAD TO THE DAMAGE OF MOTORCYCLE COMPONENTS OR RENDER MOTORCYCLES UNFIT FOR RIDING !**

**“NOTE“ POINTS OUT USEFUL TIPS.**

Use only ORIGINAL KTM SPARE PARTS.

The KTM high performance engine is only able to meet user expectations if the maintenance work is performed regularly and professionally.



REG.NO. 12 100 6061

In accordance with the international quality management ISO 9001 standard, KTM uses quality assurance processes that lead to the highest possible product quality.

© 2006 by KTM-SPORTMOTORCYCLE AG, Mattighofen AUSTRIA; All rights reserved; Reprint, also in extracts, with written allowance of KTM-SPORTMOTORCYCLE AG, Mattighofen only.

**PartShark.com**  
**877-999-5686**



## REPLY FAX FOR REPAIR MANUALS

We have made every effort to make our repair manuals as accurate as possible but it is always possible for a mistake or two to creep in.

To keep improving the quality of our repair manuals, we request mechanics and shop foremen to assist us as follows:

If you find any errors or inaccuracies in one of our repair manuals – whether these are technical errors, incorrect or unclear repair procedures, tool problems, missing technical data or torques, inaccurate or incorrect translations or wording, etc. – please enter the error(s) in the table below and fax the completed form to us at 0043/7742/6000/5349.

**NOTE:**

- Enter the complete item no. for the repair manual in column 1 (e.g.: **3.206.062-E**).  
You will find the number on the cover page or in the left margin on each right page of the manual.
- Enter the corresponding page number in the repair manual (e.g.: **5-7e**) in column 2.
- Enter the current text (inaccurate or incomplete) in column 3 by quoting or describing the respective passage of the text. If your text deviates from the text contained in the repair manual, please write your text in German or English if possible.
- Enter the correct text in column 4.

Your corrections will be reviewed and incorporated in the next issue of our repair manual.

Item no. of repair manual	Page	Current text	Correct text

Additional suggestions, requests or comments on our Repair Manuals (in German or English):

---

---

---

---

---

---

---

---

---

---

**Name mechanic/shop foreman**

**Company/work shop**

**PartShark.com**  
**877-999-5686**

# GENERAL INFORMATION

# 2

## INDEX

<b>BLEEDING THE HYDRAULIC CLUTCH</b> .....	<b>.2-2</b>
<b>ADJUSTING THE OIL PUMP (ONLY WITH SEPARATE LUBRICATION)</b> .....	<b>.2-3</b>
<b>CHECKING THE EXHAUST CONTROL</b> .....	<b>.2-4</b>
<b>CHANGING THE FRONT BRAKE FLUID</b> .....	<b>.2-5</b>
<b>CHANGING THE REAR BRAKE FLUID</b> .....	<b>.2-6</b>
<b>CHECKING BRAKE PADS AND BRAKE DISCS</b> .....	<b>.2-6</b>

PartShark.com  
877-999-5686

**PartShark.com**  
**877-999-5686**

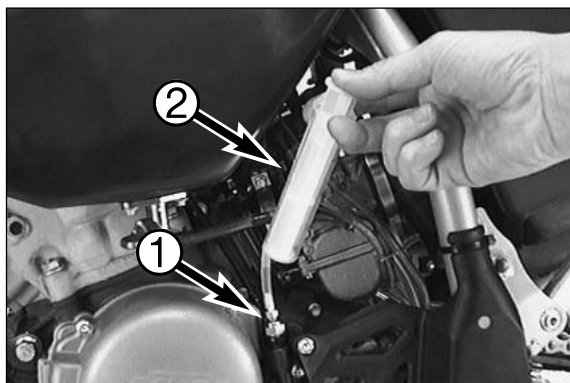

### Bleeding the hydraulic clutch

- Remove screws and take off the cover together with the rubber bellows.
- At the slave cylinder of the clutch, remove the bleeder nipple ①. Mount the bleeder syringe ② which is filled with SAE 10 biodegradable hydraulic oil (ex. Motorex Kupplungs-Fluid 75).

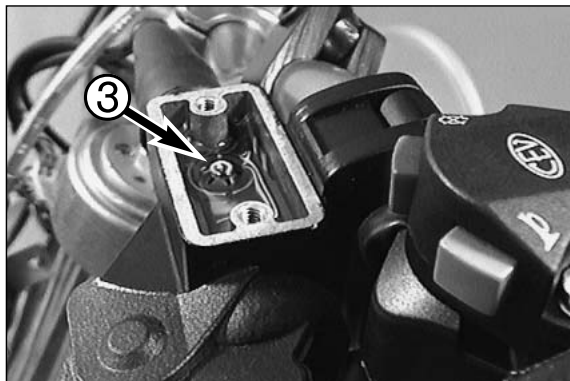

- Refill oil, until it is discharged from the bore ③ of the master cylinder in a bubble-free state. Make sure that the oil does not overflow.

---

! **CAUTION** !

---

HAVING COMPLETED THE BLEEDING PROCEDURE, YOU HAVE TO VERIFY THAT THE OIL LEVEL IN THE MASTER CYLINDER IS CORRECT. ONLY USE SAE 10 BIODEGRADABLE HYDRAULIC OIL (EX. MOTOREX KUPPLUNGS-FLUID 75) WHEN REFILLING THE MASTER CYLINDER. NEVER USE BRAKE FLUID NOR MIX BIODEGRADABLE HYDRAULIC OILS WITH MINERAL OILS.

### Adjusting the oil pump (only with separate lubrication)

NOTE: Prior to adjusting the oil pump, you have to check and if necessary, adjust the clearance of the throttle cable.

- Loosen the 3 bolts ❶ of the oil pump housing and remove the oil pump cover ❷. To make adjustment and control easier, loosen the bolts of the intake flange ❸, remove 4 of them and move the flange side wards.

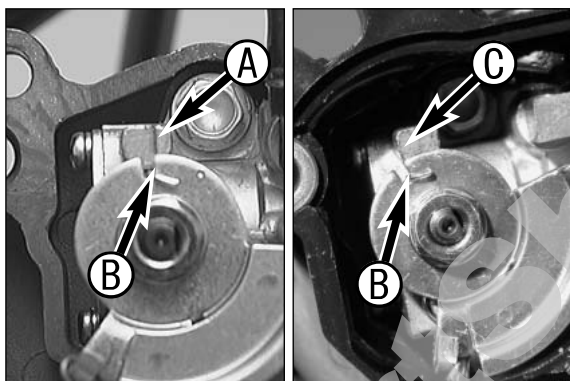
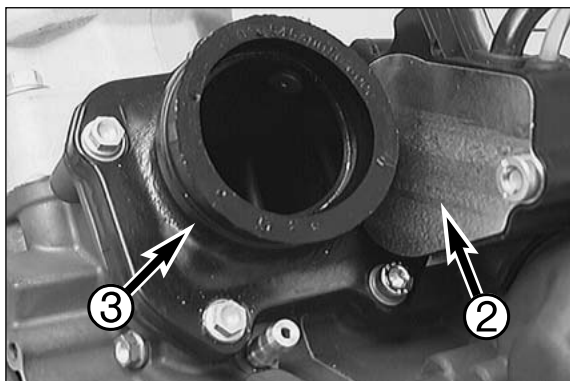
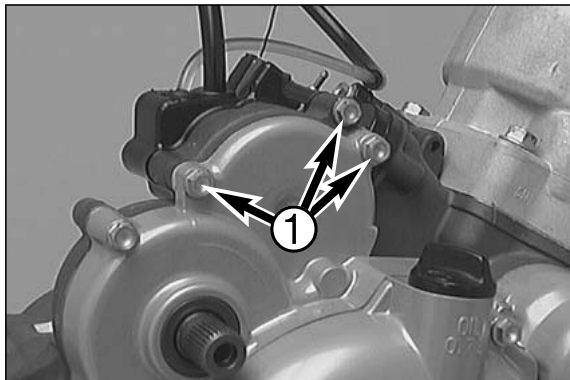

- If the oil pump has been adjusted correctly the mark ❸ must coincide with the notch ❹ on the cable pulley (except 125 EXE and 125 Supermoto).
- On 125 EXE and 125 Supermoto-models the notch ❹ must coincide with the edge ❺.

! **CAUTION** !

IF THE ADJUSTMENT OF THE OIL PUMP IS NOT CORRECT, THE ENGINE IS NOT SUPPLIED WITH THE CORRECT AMOUNT OF OIL AND THIS CAN RESULT IN ENGINE DAMAGE.

- If necessary, loosen the lock nut ❹ and correct the adjustment by turning the adjusting screw ❺ as required.
- Following the adjustment procedure, the lock nut has to be tightened again.

- Mount cover ❷ and flange ❸, tighten the 2 bolts.

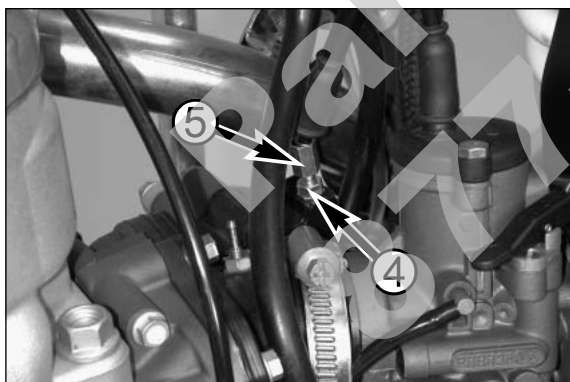

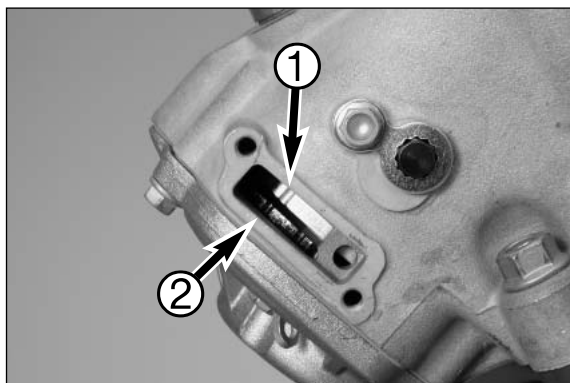

### Checking the exhaust control (engine running)

- Remove the left side cover from the cylinder.
- Start engine.
- Mark ① of the control segment should be near mark ② of the guide plate.

! **CAUTION** !

BASE POSITION MUST BE ADJUSTED WITH A DEPTH GAUGE - SHOWN IN CHAPTER 6-10 - DIMENSION "Z".

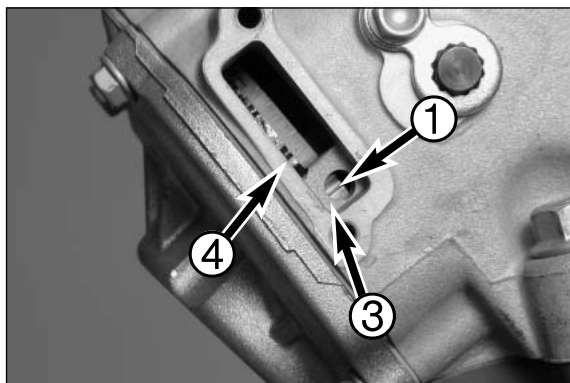

- Open throttle flap, with increasing the revolutions, mark ① moves downwards to the bore in the housing ③.

! **CAUTION** !

- Mark ④ is not used.
- If mark ① does not reach bore ③ or does not move, the exhaust control mechanism is to be overhauled.

- Mount cover and tighten the bolts.

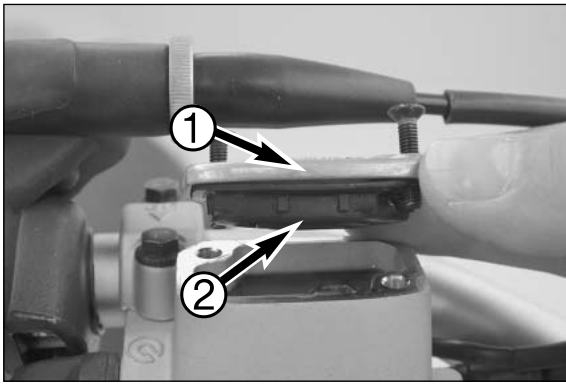

### Changing the front brake fluid

- Move the hand brake cylinder into a horizontal position.
- Disassemble the cover ❶ together with the rubber boot ❷ from the brake fluid reservoir.
- Use a syringe to extract the used brake fluid and fill with fresh DOT 5.1 brake fluid (Motorex Brake Fluid DOT 5.1).

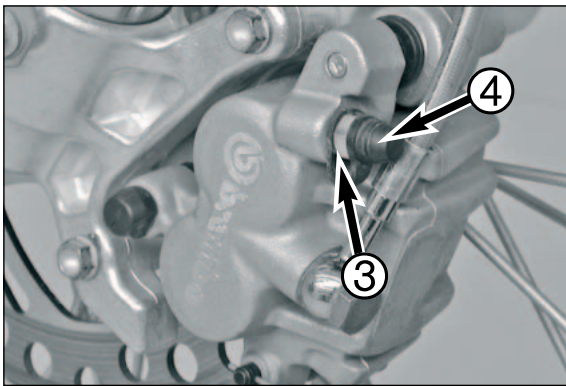

- Use a commercial extractor (shop equipment) to extract the used brake fluid out of the system through the bleeder screw ❸ on the brake caliper. Make sure the brake fluid reservoir is always filled with enough fresh brake fluid.
- Tighten the bleeder screw ❸ and attach the dust cap ❹ again.

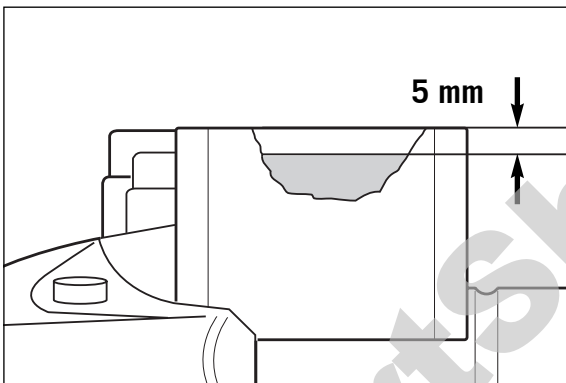

- Fill with DOT 5.1 brake fluid (Motorex Brake Fluid DOT 5.1) up to 5 mm under the top edge of the reservoir. Remount the rubber boot, cover and screws.
- Wash off any overflowing or spilled brake fluid with water.
- Pull the hand brake lever until you feel the point of pressure.

---

**! CAUTION !**

---

- NEVER USE DOT 5 BRAKE FLUID. IT IS BASED ON SILICONE OIL AND DYED PURPLE. GASKETS AND BRAKE HOSES WILL BE DAMAGED IF DOT 5 BRAKE FLUID IS USED.
- BRAKE FLUID CAN CAUSE SKIN IRRITATIONS. AVOID CONTACT WITH THE SKIN OR EYES. IF BRAKE FLUID SPLASHES INTO YOUR EYES, RINSE THOROUGHLY WITH WATER AND CONSULT A DOCTOR.
- MAKE SURE NO BRAKE FLUID COMES INTO CONTACT WITH PAINTED PARTS SINCE BRAKE FLUID WILL CORRODE THE PAINTWORK!
- ONLY USE CLEAN, NEW BRAKE FLUID FROM TIGHTLY SEALED CONTAINERS.



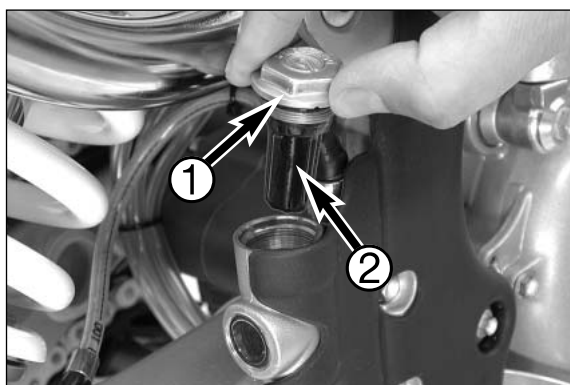

### Changing the rear brake fluid

- Move the vehicle into a vertical position.
- Disassemble the screw cap ❶ together with the rubber boot ❷ from the brake fluid reservoir.
- Use a syringe to extract the used brake fluid and fill with fresh DOT 5.1 brake fluid (Motorex Brake Fluid DOT 5.1).

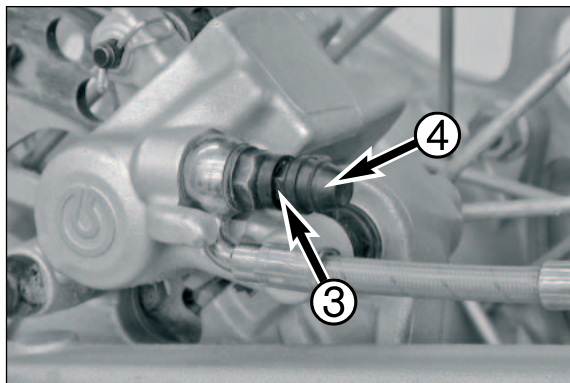

- Use a commercial extractor (shop equipment) to extract the used brake fluid out of the system through the bleeder screw ❸ on the brake caliper. Make sure the brake fluid reservoir is always filled with enough fresh brake fluid.
- Tighten the bleeder screw ❸ and attach the dust cap ❹ again.

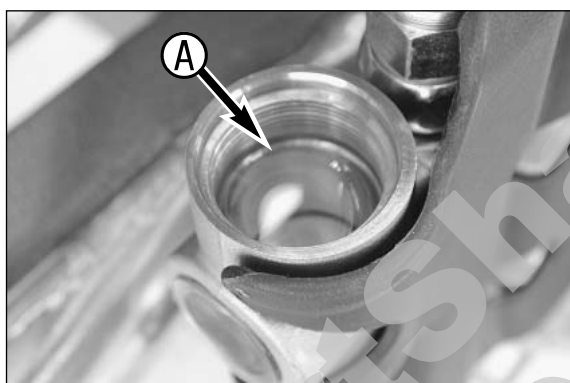

- Fill with DOT5.1 brake fluid (Motorex Brake Fluid DOT 5.1) up to the mark A on the inside of the reservoir.
- Check the O-ring of the screw cap for damage, exchange it if necessary and remount the screw cap again.
- Wash off any overflowing or spilled brake fluid with water.
- Press the foot brake pedal until you feel the point of pressure.

### CAUTION

- NEVER USE DOT 5 BRAKE FLUID. IT IS BASED ON SILICONE OIL AND DYED PURPLE. GASKETS AND BRAKE HOSES WILL BE DAMAGED IF DOT 5 BRAKE FLUID IS USED.
- BRAKE FLUID CAN CAUSE SKIN IRRITATIONS. AVOID COMING INTO CONTACT WITH THE SKIN OR EYES. IF BRAKE FLUID SPLASHES INTO YOUR EYES, RINSE THOROUGHLY WITH WATER AND CONSULT A DOCTOR.
- MAKE SURE NO BRAKE FLUID COMES INTO CONTACT WITH PAINTED PARTS SINCE BRAKE FLUID WILL CORRODE THE PAINTWORK!
- ONLY USE CLEAN, NEW BRAKE FLUID FROM TIGHTLY SEALED CONTAINERS.

### Checking brake pads and brake disks

- See Owner's Manual

**PartShark.com**  
**877-999-5686**

# REMOVING AND REFITTING ENGINE

# 3

## INDEX

<b>REMOVING THE ENGINE</b> .....	<b>.3-2</b>
<b>INSTALLING THE ENGINE</b> .....	<b>.3-3</b>

PartShark.com  
877-999-5686

**PartShark.com**  
**877-999-5686**



## Removing the engine

NOTE: The cylinder head and the cylinder can be removed without removing the engine. It is also possible to work on the clutch, the primary drive and the shift drum locating device without removing the engine. The water pump can be removed and installed without removing the clutch cover.

- Thoroughly clean the motorcycle.
- Use a suitable supporting device to jack up the motorcycle.
- Remove the seat and the tank with the spoilers.

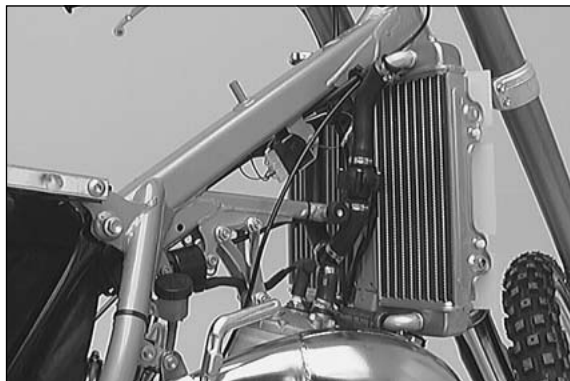

- Drain the cooling liquid.
- Remove the exhaust system and the engine brace.
- Disconnect the radiator hoses at the engine.
- Remove the carburetor.

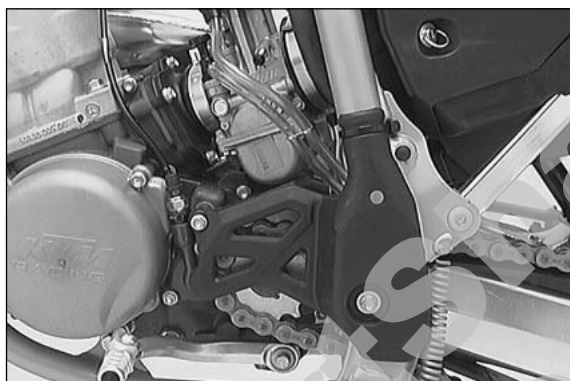

- Dismount the brake cylinder cover (does not apply to SX/SXS from model 2007).
- Remove the engine sprocket cover and the chain.
- Disconnect the electrical wires.



- Unscrew the clutch master cylinder and reposition the clutch line such that it will not get entangled when the engine is lifted out.
- Unhook the return spring of the foot brake pedal from the clutch cover.

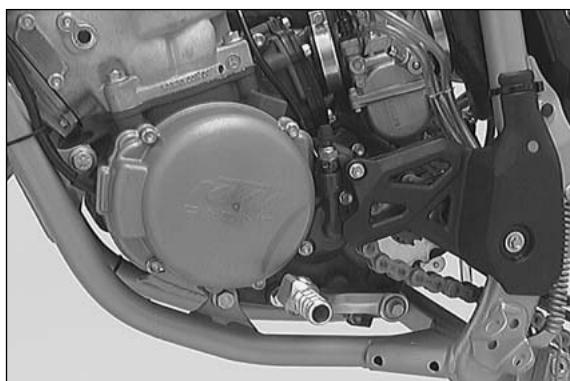

- Undo the engine mounting bolts.
- Remove the swingarm pivot and pull the swingarm backwards.
- Lift the engine out of the frame on the left side.

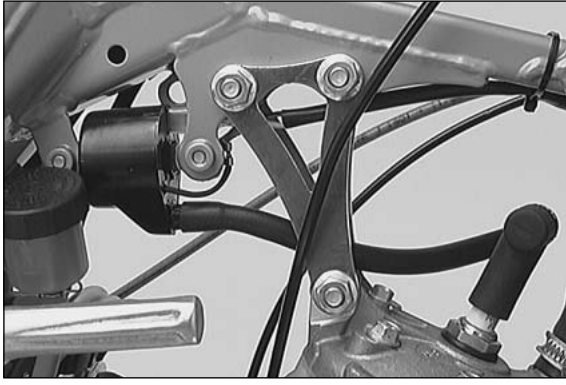

### Installing the engine

- Lift the engine into the frame from the left side, slightly grease and mount the swingarm pivot. Tighten the collar nut with 100 Nm.
- Screw in the engine mounting bolts.
- Mount the engine brace.

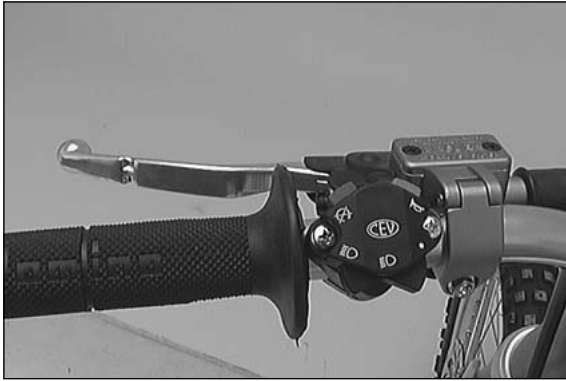

- Connect the electrical wires.
- Position the clutch line correctly, and the mount clutch master cylinder on the handlebar.

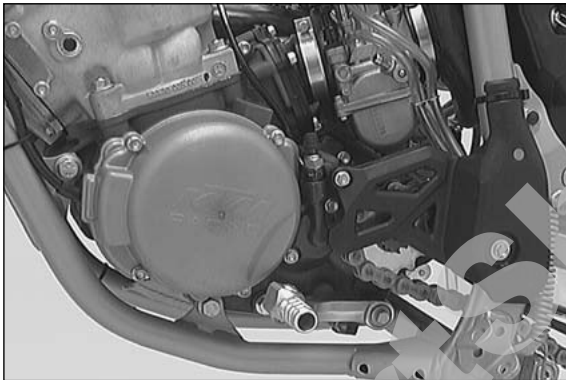

- Mount the chain and the engine sprocket cover.

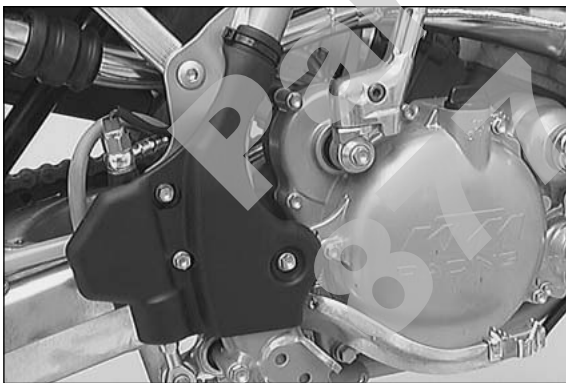

- Mount the brake cylinder cover (does not apply to SX/SXS from model 2007).

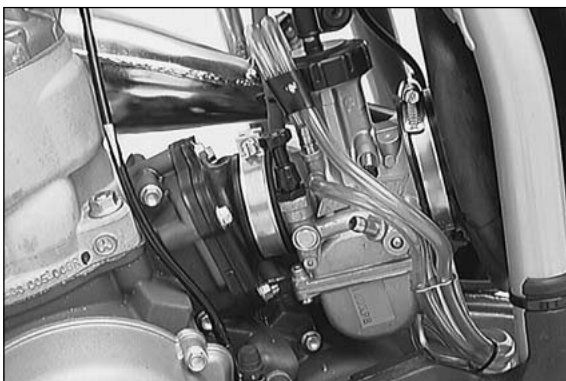

- Mount the carburetor.

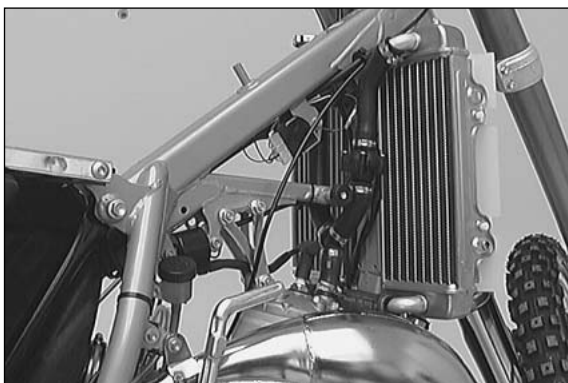

- Connect the radiator hoses to the engine and fill the cooling system with a mixture of 40 % antifreeze and 60 % water. Undo out the bleeder screws on the cylinder head and on the right radiator (if fitted). Retighten the screws as soon as the cooling liquid that emerges is free of air bubbles.

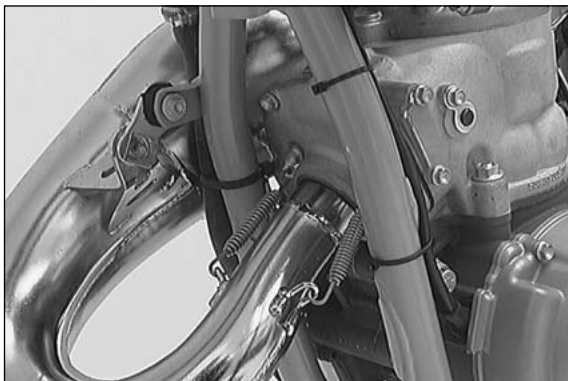

- Mount the exhaust system.
- Mount the tank with the spoilers and the seat.

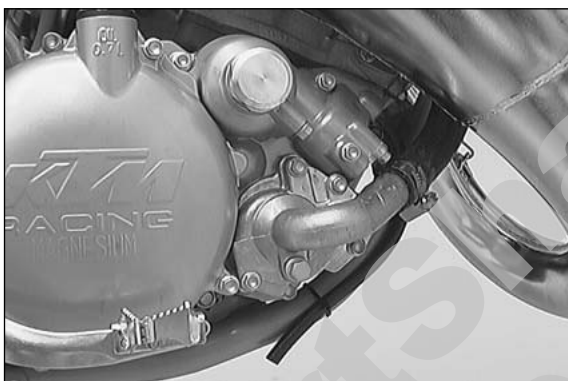

- Fix the breather tube to the frame.
- Check the electrical system for faultless operation.
- Adjust the carburetor.
- Test ride.
- After the test ride check the engine, the cooling system and the exhaust system for leaks.

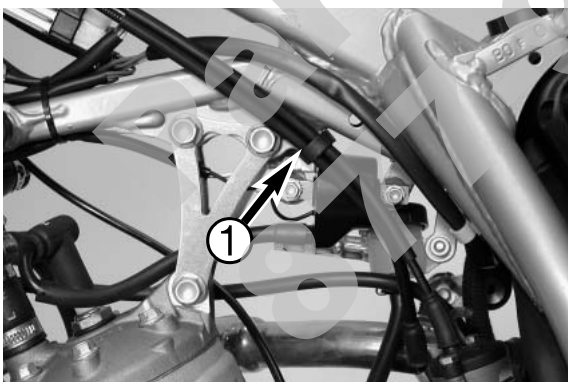

#### Fixing the cables to the frame - Models with separate lubrication

! CAUTION !

TO PREVENT DISENGAGEMENT OF THE THROTTLE CABLE AND THE OIL PUMP CABLE IT IS NECESSARY TO FIX ❶ THE CABLES ABOVE THE CARBURATOR TO THE FRAME.

**PartShark.com**  
**877-999-5686**



# DISASSEMBLING THE ENGINE

# 4

## INDEX

<b>SPECIAL TOOLS – ENGINE 125/200</b> .....	<b>4-2</b>
<b>DRAINING THE GEAR OIL</b> .....	<b>4-3</b>
<b>DISMOUNTING THE CLUTCH SLAVE CYLINDER</b> .....	<b>4-3</b>
<b>CYLINDER HEAD, CYLINDER AND PISTON</b> .....	<b>4-3</b>
<b>IGNITION</b> .....	<b>4-4</b>
<b>ENGINE SPROCKET</b> .....	<b>4-4</b>
<b>REED VALVE HOUSING, INTAKE FLANGE AND CLUTCH COVER</b> .....	<b>4-5</b>
<b>REED VALVE HOUSING, INTAKE FLANGE AND OIL PUMP</b> <b>- MODELS WITH SEPARATE LUBRICATION</b> .....	<b>4-6</b>
<b>REMOVING THE CLUTCH AND PRIMARY DRIVE</b> .....	<b>4-6</b>
<b>SHIFT DRUM LOCATING, KICKSTARTER</b> .....	<b>4-7</b>
<b>DIVIDING THE ENGINE HOUSING</b> .....	<b>4-8</b>
<b>REMOVING THE SHIFT MECHANISM AND TRANSMISSION</b> .....	<b>4-9</b>
<b>REMOVING THE CRANKSHAFT</b> .....	<b>4-9</b>

**PartShark.com**  
**877-999-5686**

## SPECIAL TOOLS – ENGINE 125 / 200

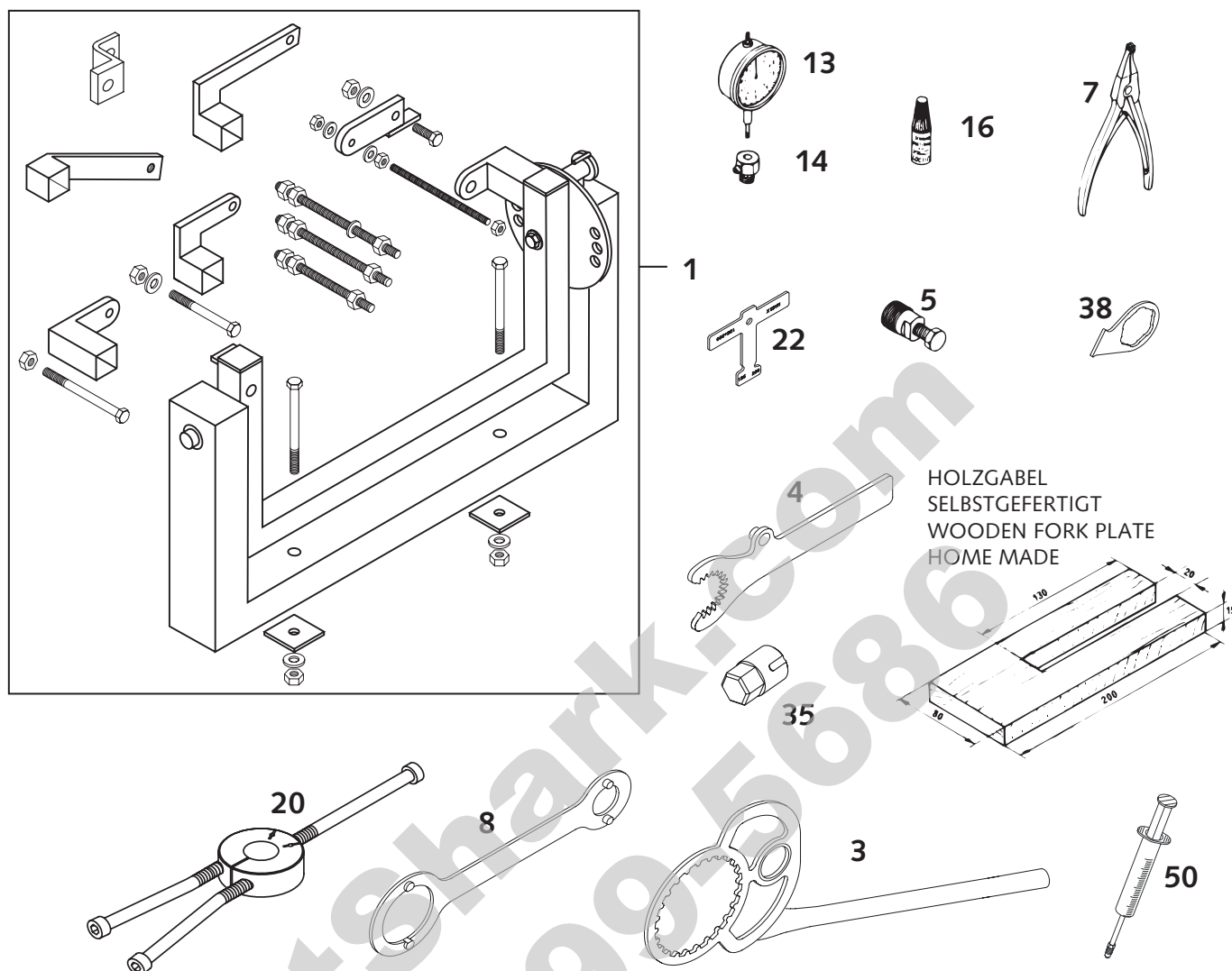

Art.-Nr. 3.206.062-E

Repair manual KTM 125 / 144 / 150 / 200

FIG	PART. NO.	DESCRIPTION
1	560.12.001.000	Universal engine work stand
3	503.29.003.000	Clutch holder 125 / 200
4	503.29.004.000	Holding spanner for primary gear wheel
5	546.29.009.044	Magneto extractor M27x1 Kokusan
7	510.12.011.000	Circlip plier
8	546.29.012.100	Holding spanner for flywheel Kokusan 2K-1/2/3/4
13	501.12.013.000	Dial gauge 1-10 mm
14	501.12.030.000	Dial gauge support
16	6 899 785	Loctite 243 blue 6 ccm
20	584.29.037.037	Mounting tool inner ring NJ206
22	503.29.022.000	Adjusting plate for control flap
38	503.29.038.000	Holding plate for locating drum
50	503.29.050.000	Vent injection hydr. clutch

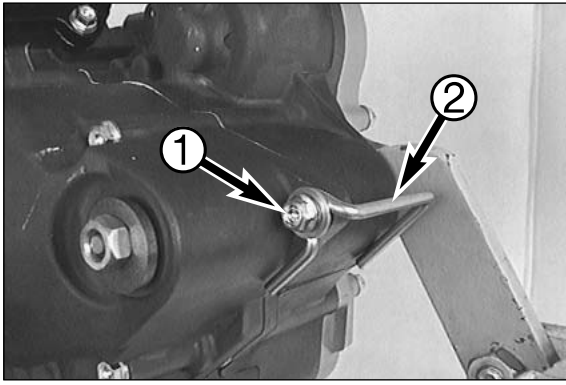

- Thoroughly clean the engine.
- Clamp the engine into the mounting rack.
- Remove the kickstarter and the shift lever.

up to model 2002:

- Remove bolt **1** and take off wire hanger **2**.

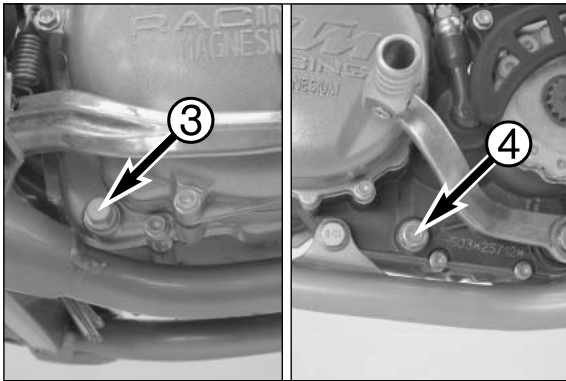

#### Draining the gear oil

- Remove oil drain plugs **3** and **4** and drain the used oil into an appropriate container.

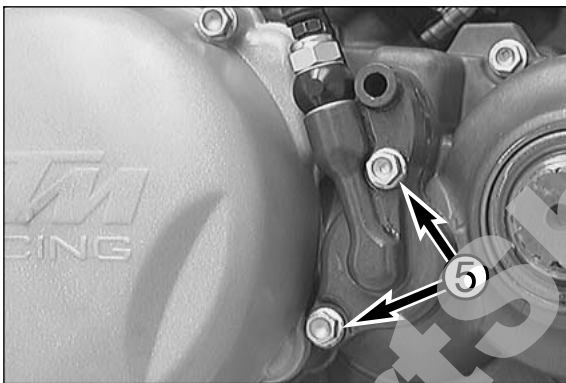

#### Dismounting the clutch slave cylinder

- Remove the 2 bolts **5** and withdraw the clutch slave cylinder together with the gasket.
- Pull the push rod out of the drive shaft.

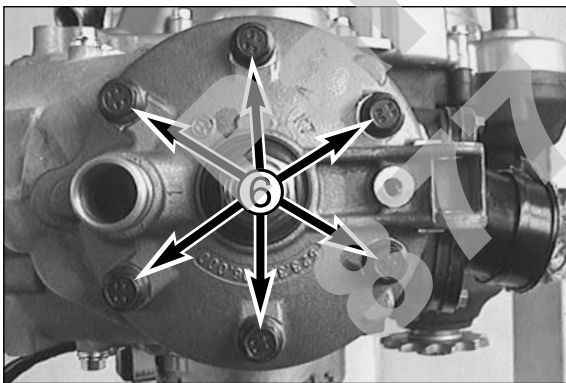

#### Cylinder head, cylinder and piston

- Undo the 6 bolts **6** and remove the cylinder head together with the gasket.

NOTE: An O-ring is used instead of the gasket on 125 cc engines from model 2002 onwards and 200 cc engines from model 2003 onwards.

- Take the O-ring(s) out of the groove in the cylinder.

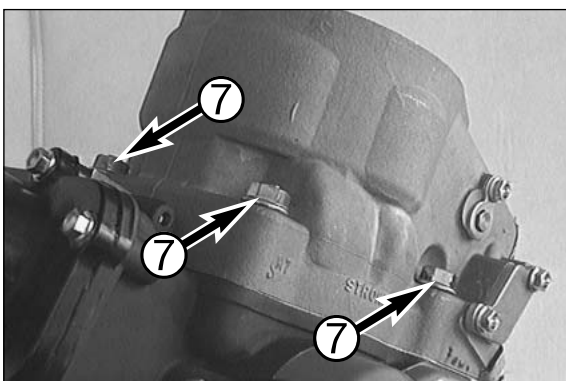

- Remove the 4 collar nuts **7** at the cylinder base and remove the cylinder.

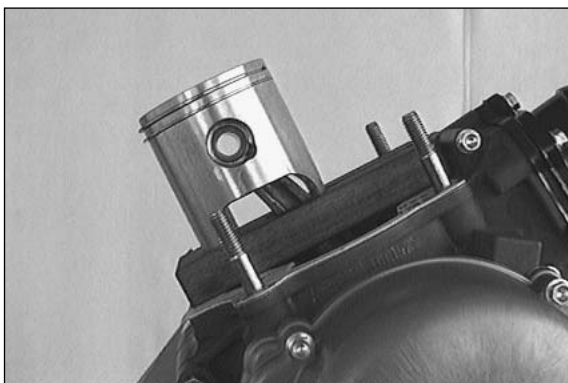

- Cover the crankcase.
- Place the piston onto an appropriate wooden support and remove both piston pin retainers.
- Press the piston pin out of the piston without applying excessive force. An appropriate mandrel can be used if necessary.
- Remove the piston and take the piston pin bearing out of the conrod eye.
- Remove the cylinder base gaskets.

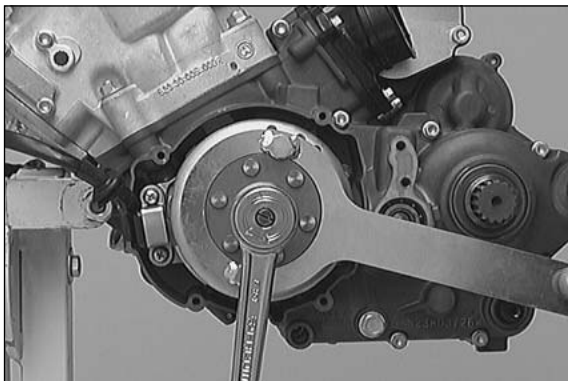

### Ignition

- Remove the 4 bolts and take off the ignition cover together with the gasket.
- Hold the rotor with the special tool and undo the hexagon nut.
- Take the hexagon nut and the detent edged ring off the crankshaft.

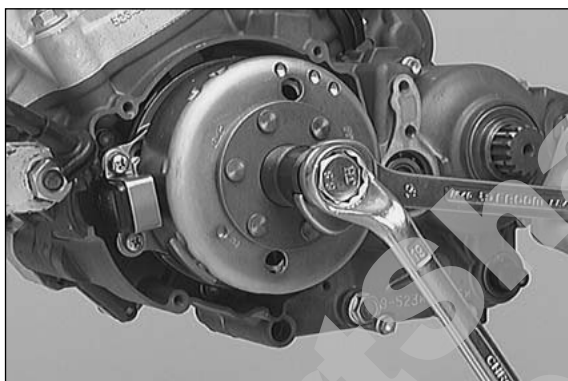

- Twist the rotor extractor into the thread of the rotor (LH thread) and remove the rotor.

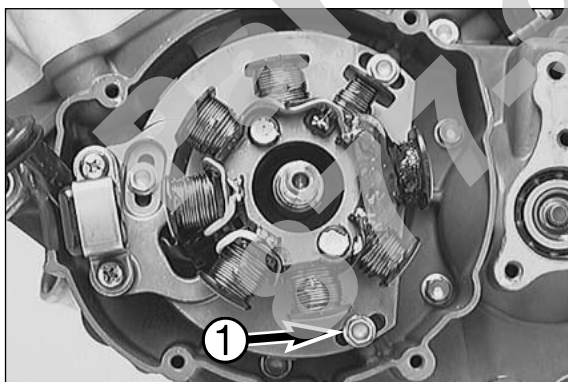

- Remove the 3 collar bolts ❶ and take the stator out of the housing.
- Take the woodruff key out of the crankshaft.

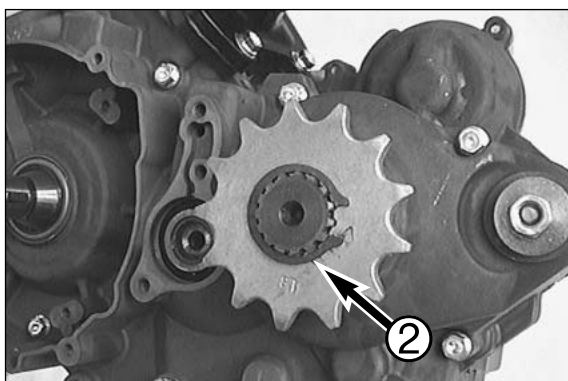

### Engine sprocket

- Use a pair of circlip pliers to take the circlip ❷ off the countershaft.
- Take the engine sprocket, the distance bushing and the O-ring off the countershaft.

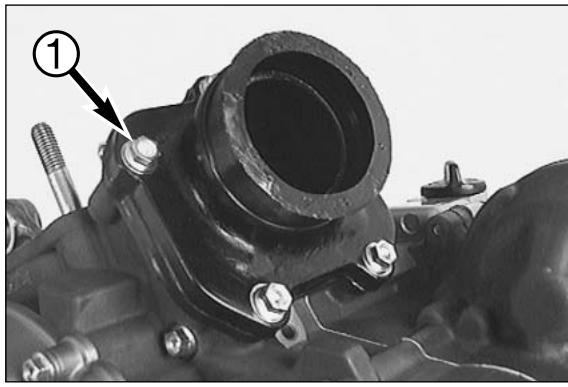

### Reed valve housing, intake flange and clutch cover

- Remove the 5 bolts ① together with the corrugated washers, remove the intake flange and the reed valve housing.

NOTE: An O-ring is used instead of the gasket on 125 cc engines from model 2002 onwards and 200 cc engines from model 2003 onwards.

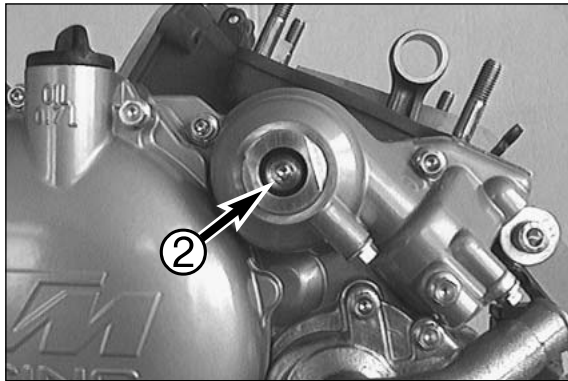

NOTE: The following step need not be performed unless you intend to take the centrifugal timer out of the clutch cover.

- Remove the cover ③ of the centrifugal timer together with the seal ring and undo screw ②.

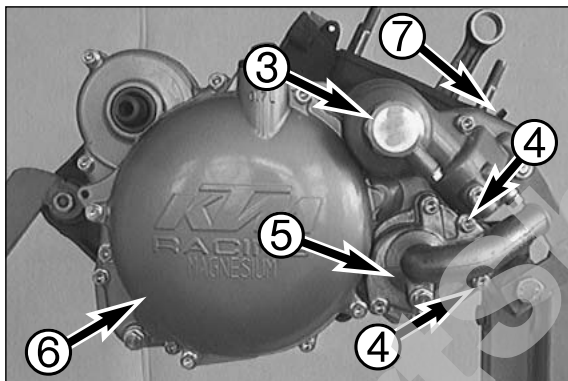

- Remove all bolts of the clutch cover and the 2 front-end bolts ④ of the water-pump cover, then dismantle the clutch cover.
- Remove the clutch cover gasket and pull the dowels out of the housing.
- Take the O-ring ③ out of the water bore.

NOTE: The water pump cover ⑤, exterior cap ⑥ and the hexagon cap nut ③ need not be removed. The water pump and the centrifugal timer are left in the clutch cover.

---

**CAUTION**

---

WHEN REMOVING THE CLUTCH COVER MAKE SURE THAT THE ROCKER ARM ⑦ OF THE EXHAUST CONTROL DOES NOT JAM IN THE HOUSING AND IS NOT DAMAGED.

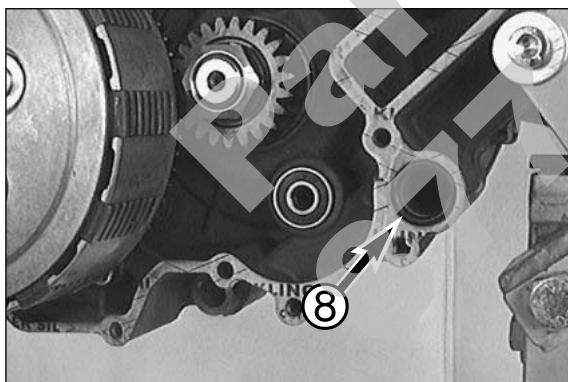

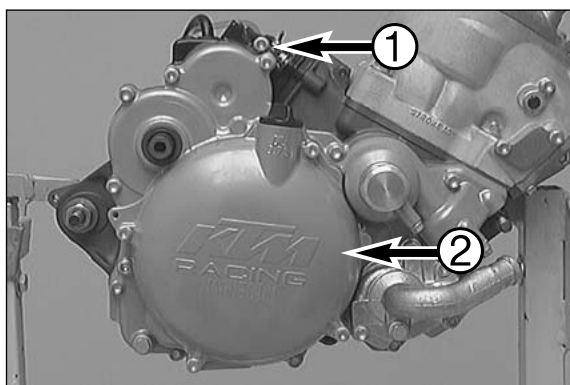

### Reed valve housing, intake flange and oil pump (separate lubrication)

- When dismantling the clutch cover ② additionally remove the bolt ①

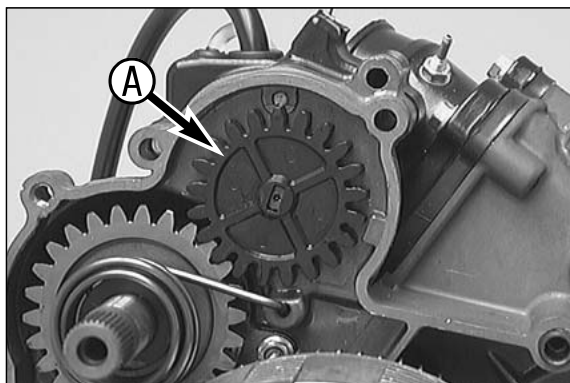
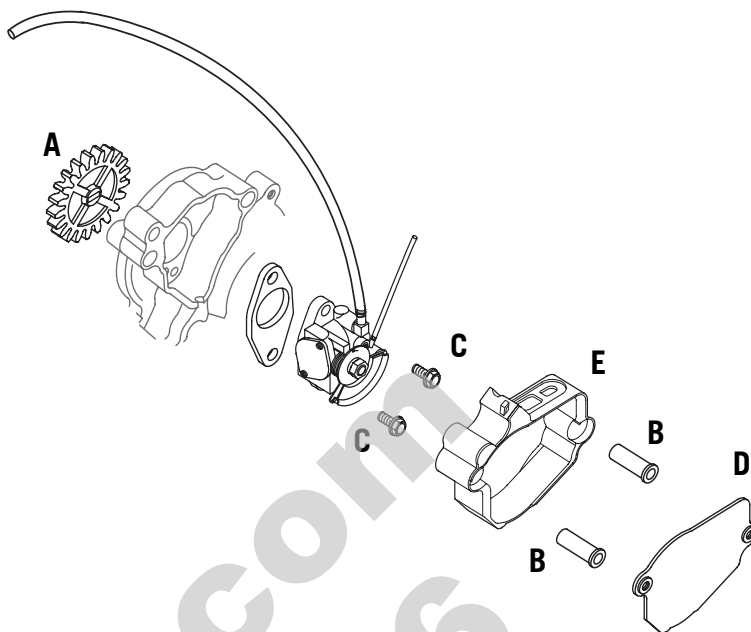

- Pull the oil pump wheel A off the oil pump
- Remove the cover D from the oil pump housing.
- Remove the 4 bolts of the intake flange and then move the intake flange sideways as shown.
- Pull the 2 dowel bushings B out of the housing.

NOTE: Bolt ③ at the intake flange can only be unscrewed when the oil pump housing E has been dismantled.

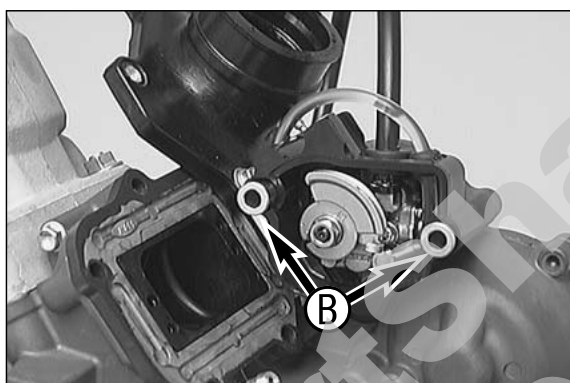

- Pull the oil pump housing off the engine case and swing it sideways (see picture).
- Remove the 2 bolts C, and withdraw oil pump together with gasket from the engine case.
- Remove the bolt ③ at the intake flange, and dismantle the intake flange together with reed valve housing.

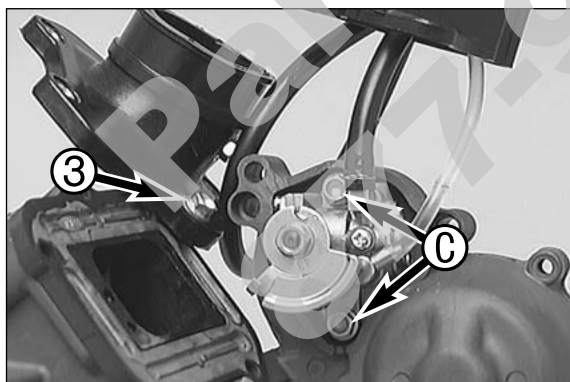

### Removing the clutch and primary drive

- Undo the 5 bolts ④ in diagonal order to prevent jamming of the clutch discs when the springs relax.
- Remove bolts, spring retainers and springs.
- Take the pressure cap and the disc package out of the outer clutch hub.
- Pull the thrust bearings out of the main shaft.

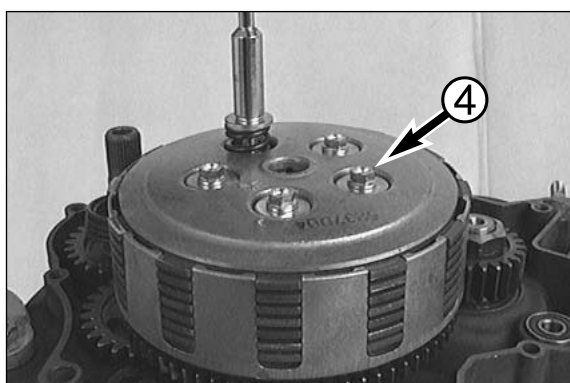



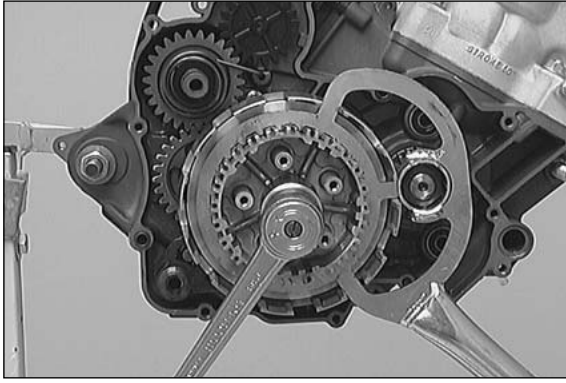

- Open the lock washer of the inner clutch hub.
- Mount the clutch holder on the inner clutch hub and undo the hexagon nut.
- Remove the clutch holder.
- Take the hexagon nut, the lock washer and the inner clutch hub off the main shaft.

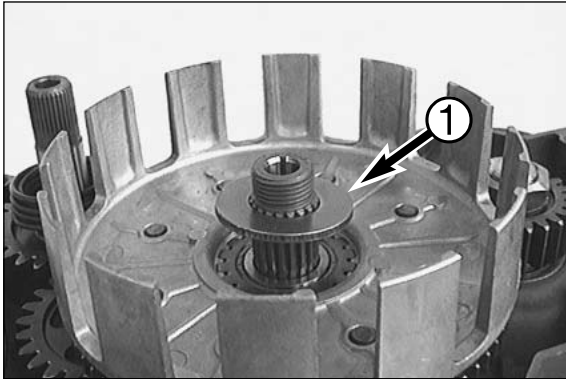

- Take the supporting disc ① and the outer clutch hub together with the bearing off the main shaft.

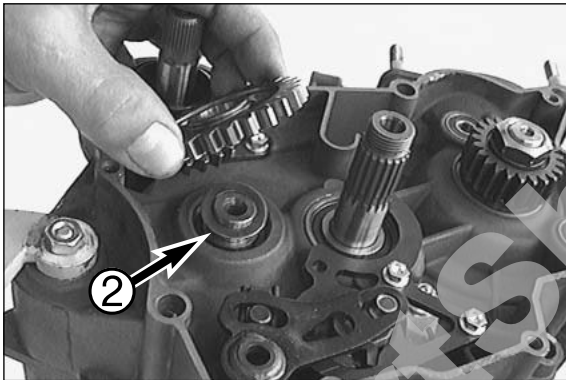

- Remove the intermediate starter gear and the stop disc ②.

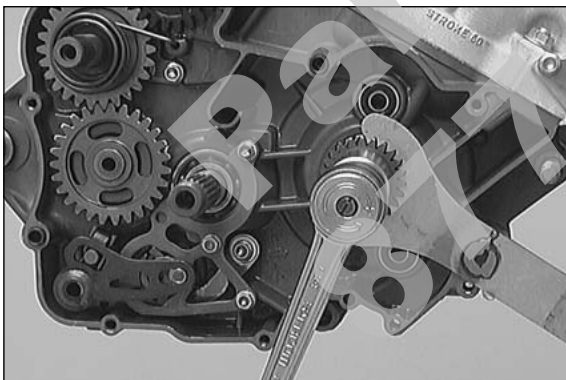

- Mount the primary gear holder and undo the hexagon nut (LH thread).
- Remove the primary gear holder.
- Take the hexagon nut, the detent edged ring and the primary gear off the crankshaft.
- Take the woodruff key out of the crankshaft.

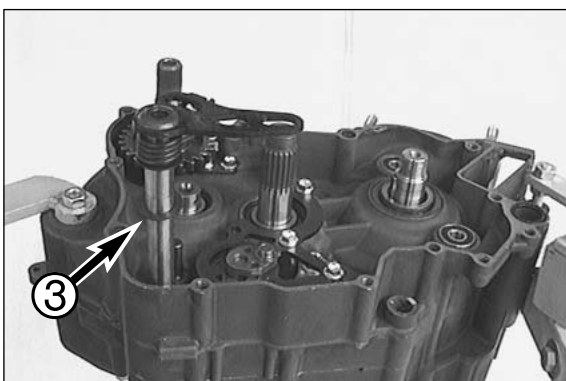

### Shift drum locating, kickstarter

- Simply pull the shift shaft out of the housing. Keep in mind the stop disc ③ (It can be left in the housing).



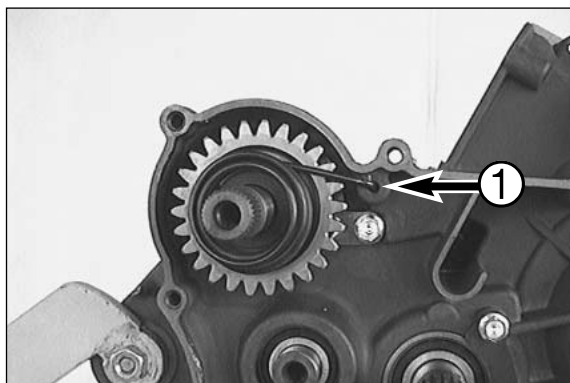

- Carefully unhook the kickstarter spring from bore **1**, (pretensioned spring) and release it.
- Rotate the kickstarter shaft approximately 1/4 turn counterclockwise and pull it out of the housing. Keep in mind the stop disc behind !

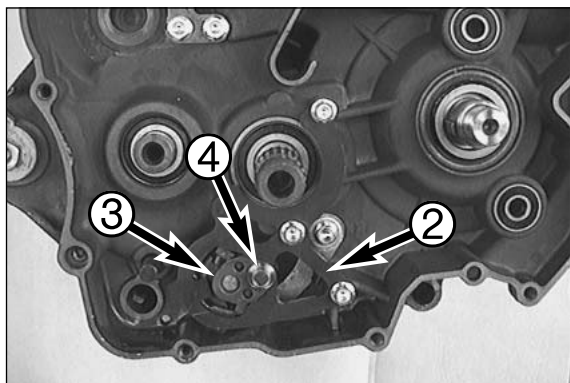

- Undo the 3 bolts and remove the gear shifting gate **2** together with the ratchet carrier **3**. Proceed with care by watching out for the collar bushing **4** on the ratchet carrier.

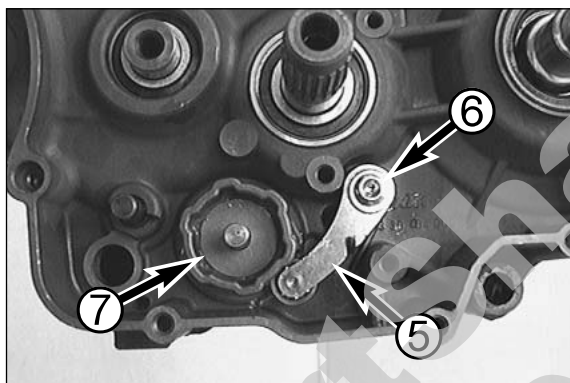

- The locking lever **5** need not be removed unless the engine housing is exchanged.
- To do this, undo bolt **6**, then remove the locking lever together with the spring.
- Take the washer **7** out of the locking drum.

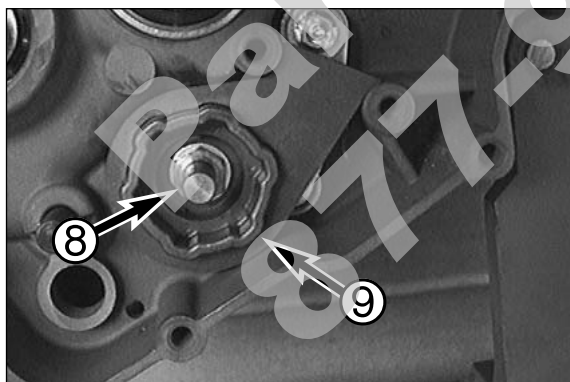

- Hold the locking drum **9** with the special tool, undo bolt **8** and remove the bolt together with the washer.
- Pull the locking drum off the shift roller.

---

**! CAUTION !**

---

THE LOCKING DRUM MUST BE HELD WITH THE SPECIAL TOOL TO PREVENT DAMAGING THE BUSHINGS ON THE DRIVING PINS OF THE SHIFT FORKS.

### Dividing the engine housing

- Swing the ignition side upwards and remove all 12 housing bolts.
- Undo the engine mounting device on the mounting rack.
- Lift the left housing half by the lifting points of the housing, using appropriate tools, or separate it from the right housing half by lightly tapping the countershaft with a plastic hammer.

---

**! CAUTION !**

---

TO PREVENT DAMAGING THE SEALING SURFACES, DO NOT USE A SCREWDRIVER OR SIMILAR TOOL TO LEVER THE HOUSING HALVES APART!

- Remove the housing half and the gasket.
- Keep in mind the stop disc of the main shaft (it can stick to the inside of the housing).

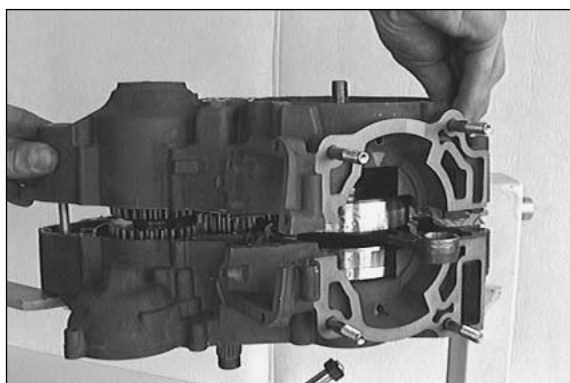

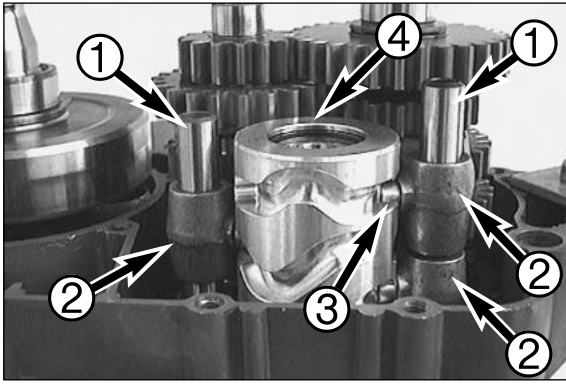

### Removing the shift mechanism and transmission

- Pull out the shift rails ① and swing the shift forks ② including the rollers ③ sideways.
- Pull the shift roller ④ out of the grooved ball bearing.
- Take the shift forks ② out of the housing.

NOTE: When dismantling the shift forks, make sure that you do not lose the rollers ③ on the shift forks.

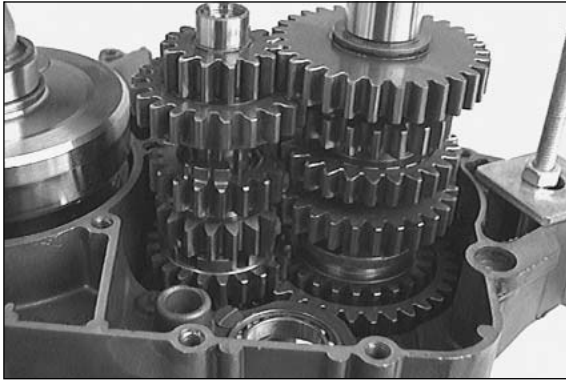

- Pull the complete main shaft and the countershaft together out of the bearing seats.

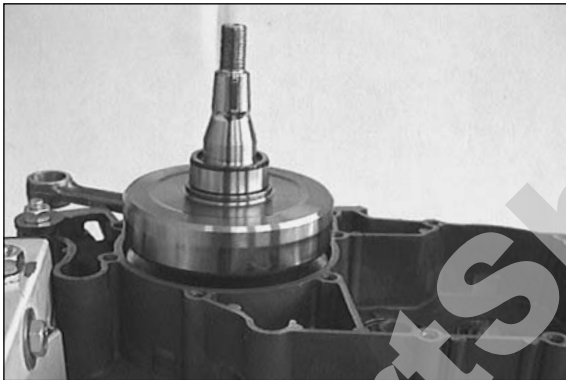

### Removing the crankshaft

- Pull the crankshaft out of the bearing seat (if necessary lightly tap it with a plastic hammer).

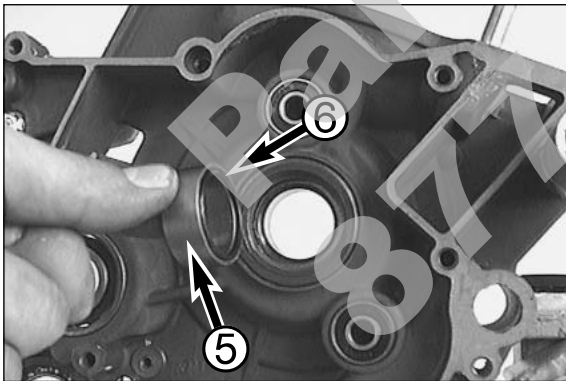

- Take the distance bushing ⑤ and the O-ring ⑥ out of the right crankshaft seal ring.

- Clean all parts, check for wear and exchange worn components.

NOTE: All gaskets, shaft seal rings, O-rings and bearings should be exchanged on each complete engine overhaul.

# SERVICING INDIVIDUAL COMPONENTS

# 5

## INDEX

<b>RIGHT HOUSING HALF</b> .....	<b>5-2</b>
<b>LEFT HOUSING HALF</b> .....	<b>5-3</b>
<b>CRANKSHAFT</b> .....	<b>5-4</b>
<b>CRANKSHAFT WEBS – MEASURE OUTER DIMENSION</b> .....	<b>5-4</b>
<b>PISTON</b> .....	<b>5-4</b>
<b>PISTON RING END GAP</b> .....	<b>5-4</b>
<b>CHECKING THE CYLINDER FOR WEAR</b> .....	<b>5-5</b>
<b>NIKASIL COATING OF CYLINDER</b> .....	<b>5-5</b>
<b>DISMOUNTING AND CHECKING THE EXHAUST CONTROL SYSTEM IN THE CYLINDER</b> .....	<b>5-6</b>
<b>PREASSEMBLING THE CYLINDER</b> .....	<b>5-7</b>
<b>DISMOUNTING THE EXHAUST CONTROL SYSTEM IN THE CLUTCH COVER AND CHECKING PARTS FOR WEAR</b> .....	<b>5-10</b>
<b>PREASSEMBLING THE CLUTCH COVER</b> .....	<b>5-10</b>
<b>DISASSEMBLING AND CHECKING THE WATER PUMP</b> .....	<b>5-11</b>
<b>PREASSEMBLING THE WATER PUMP</b> .....	<b>5-11</b>
<b>CHECKING THE CLUTCH FOR WEAR</b> .....	<b>5-12</b>
<b>REED VALVE HOUSING, INTAKE FLANGE</b> .....	<b>5-13</b>
<b>KICKSTARTER</b> .....	<b>5-14</b>
<b>PREASSEMBLING THE KICKSTARTER SHAFT</b> .....	<b>5-14</b>
<b>SHIFTING MECHANISM</b> .....	<b>5-16</b>
<b>PREASSEMBLING THE SHIFTING SHAFT</b> .....	<b>5-16</b>
<b>TRANSMISSION</b> .....	<b>5-17</b>
<b>ASSEMBLING THE MAIN SHAFT</b> .....	<b>5-17</b>
<b>ASSEMBLING THE COUNTERSHAFT</b> .....	<b>5-18</b>
<b>IGNITION, SPARK PLUG</b> .....	<b>5-19</b>
<b>CHECK STATOR AND PULSE GENERATOR</b> .....	<b>5-19</b>

### Engine housing

Note: Read through the following section before commencing work. Then determine the assembly sequence so that the engine housing halves only need to be heated up once before replacing the bearings.

Having first removed the dowels, in order to expel the bearings or remove them with light mallet blows, the housing halves must be placed on a suitably large plane surface, supporting the whole of the sealing surface without damaging it. A wooden panel is best used as a base.

Bearings or shaft seal rings should not be hammered into their seats. If no suitable press is available, use a suitable mandrel and hammer them in with great care. Cold bearings will normally drop into their seats at an engine housing temperature of approx. 150° C.

After cooling, should the bearings fail to lock in the bore, they are bound to rotate after warming. In this event the housing must be replaced.

**PartShark.com**  
**877-999-5686**

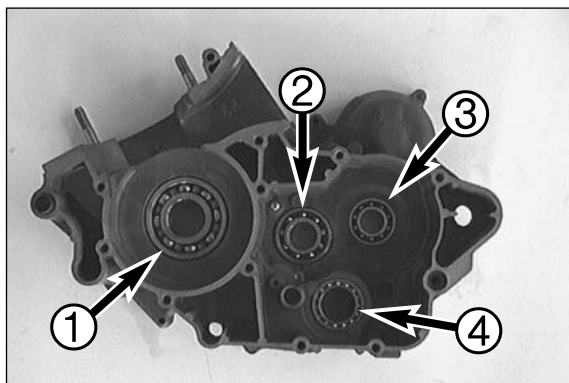

### Right housing half

Remove the shaft seal rings and use a hot plate to heat the housing half to a temperature of approximately 150° C.

NOTE: At a temperature of 150° C it is usually sufficient to tap the housing half onto a plane wooden surface and the bearings will simply drop out of the bearing seats. However, in some cases it is necessary to press the bearings out of their seats. To prevent damaging of the bearings, the device used to press in the new bearings must be designed in such a way that it touches only the outer ring of the bearing.

#### Grooved ball bearing of the crankshaft ❶

Press the old grooved ball bearing inwards from the outside. Insert a new grooved ball bearing from the inside and press it all the way into the seat.

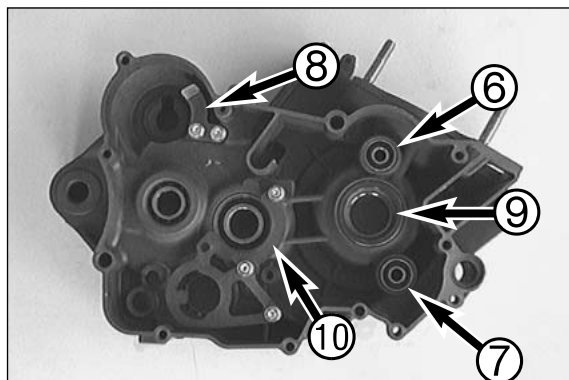

#### Grooved ball bearing of the main shaft ❷

Apply a suitable mandrel on the outside to press the grooved ball bearing inwards.

Before pressing the new grooved ball bearing inwards, mount the gear shifting gate ❶. Then, the grooved ball bearing can be pressed in from the inside and up to the stop.

### ! CAUTION !

APPLY ONLY A LIGHT PRESSURE WHEN PRESSING IN THE GEAR SHIFTING GATE. OTHERWISE, YOU WILL DAMAGE THE SHIFTING GATE.

#### Grooved ball bearing of the countershaft ❸

Apply a suitable mandrel on the outside to press the old grooved ball bearing inwards. Insert a new grooved ball bearing from the inside and press it all the way into the seat.

#### Grooved ball bearing of the shift roller ❹

Apply a suitable mandrel on the outside to press the old grooved ball bearing inwards. Insert a new grooved ball bearing from the inside and press it all the way into the seat.

### ! CAUTION !

– MODEL 2000 ONWARDS THE GROOVED BALL BEARING IS SECURED WITH A SCREW ❶, THIS IS TO BE REMOVED BEFORE PRESSING OUT THE BEARING AND TO BE MOUNTED AFTER PRESSING IN THE BEARING.

DUE TO THIS SCREW ❶ THE SHIFT ROLLER HAS CHANGED. AN "OLD" SHIFT ROLLER CAN NOT BE MOUNTED WITH A SCREW SECURING THE BEARING.

– DO NOT APPLY EXCESSIVE FORCE WHEN PRESSING THE GROOVED BALL BEARINGS FLUSH WITH THE COLLAR IN THE HOUSING. THE COLLAR WALL IS VERY THIN AND CAN EASILY BE DAMAGED!

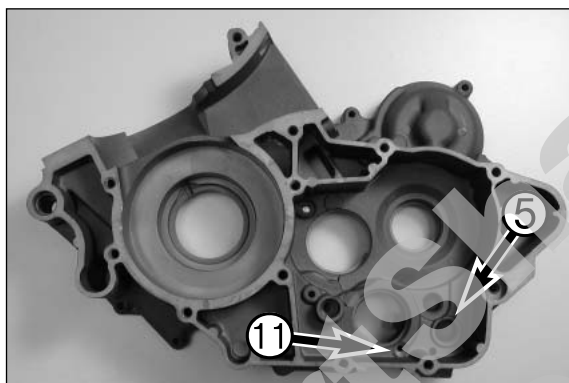

#### Needle bearing of the shifting shaft ❺ (from model 2002 on)

Use a suitable mandrel to press out the needle bearing. Insert the new needle bearing and press it all the way in.

#### Grooved ball bearing of the centrifugal timer ❻

Use an interior extractor and a Ø 5-7 mm insert to pull the grooved ball bearing out of the housing. Press a new grooved ball bearing all the way into the seat.

#### Grooved ball bearing of the water pump shaft ❼

Use an interior extractor and a Ø 5-7 mm insert to pull the grooved ball bearing out of the housing. Press a new grooved ball bearing all the way into the seat.

#### Kickstarter release plate ❸

When exchanging the release plate apply Loctite 243 to both bolts.

#### Shaft seal ring of the crankshaft ❾

Insert a new shaft seal ring from the outside and press it in flush with the open side facing inwards.

Then check the lubrication bore for the grooved ball bearing ❶ of the crankshaft for obstructions.

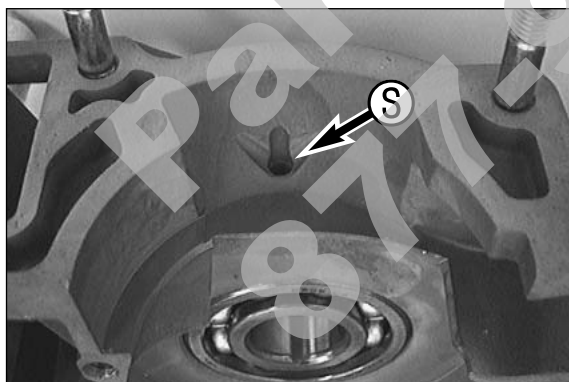

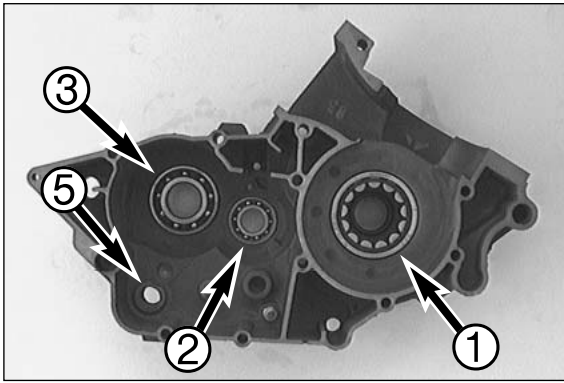

### Left housing half

Remove the shaft seal rings and use a hot plate to heat the housing half to a temperature of approximately 150° C.

NOTE: At a temperature of 150° C it is usually sufficient to tap the housing half onto a plane wooden surface and the bearings will simply drop out of the bearing seats. However, in some cases it is necessary to press the bearings out of their seats. To prevent damaging the bearings, the device used to press in the new bearings must be designed in such a way that it touches only the outer ring of the bearing.

#### Roller bearing of the crankshaft ❶

Apply a suitable mandrel on the outside to press the roller bearing inwards. Insert a new roller bearing from the inside and press it all the way into the seat.

#### Grooved ball bearing of the main shaft ❷

Apply a suitable mandrel on the outside to press the grooved ball bearing inwards. Insert a new grooved ball bearing from the inside and press it all the way into the seat.

**! CAUTION !**

TO PREVENT DAMAGING THE HOUSING, NEVER APPLY TOO MUCH FORCE WHEN PRESSING IN GROOVED BALL BEARINGS.

#### Grooved ball bearing of the countershaft ❸

Apply a suitable mandrel on the outside to press the grooved ball bearing inwards. Insert a new grooved ball bearing from the inside and press it all the way into the seat.

#### Shaft seal ring of the countershaft ❹

Insert a new shaft seal ring from the outside and press it in flush. Do not forget the stop disc (position it on the grooved ball bearing of the countershaft before mounting).

#### Needle bearing of the shifting shaft ❺ (from model 2002 on)

Use a suitable mandrel to press out the needle bearing. Insert the new needle bearing and press it all the way in.

#### Shaft seal ring of the shifting shaft ❻

Insert a new shaft seal ring from the outside and press it in flush.

#### Shaft seal ring of the crankshaft ❼

Insert a new shaft seal ring from the outside and press it in flush.

#### Lubrication bore of the crankshaft roller bearing ❽

Check for obstructions and, if necessary clean the bore with compressed air.

Check if the oil guiding rubber ❸ of the left housing half is correctly mounted (i.e. with the narrower end of the guide slots facing inwards) and apply a small quantity of grease to fix it in the housing. Brittle or hard oil guiding tubes must be replaced.

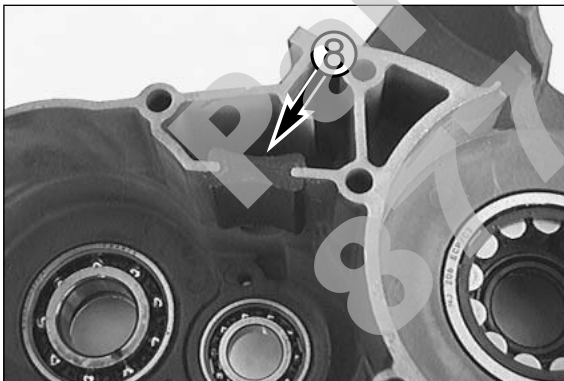
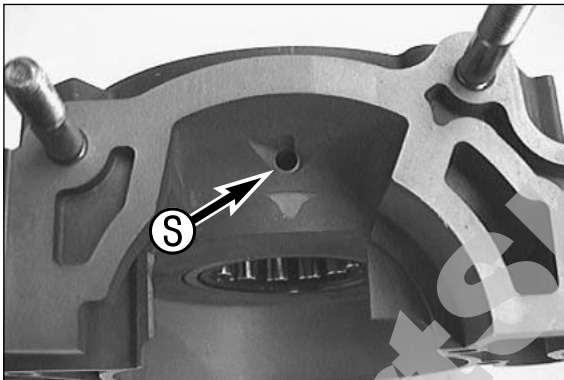
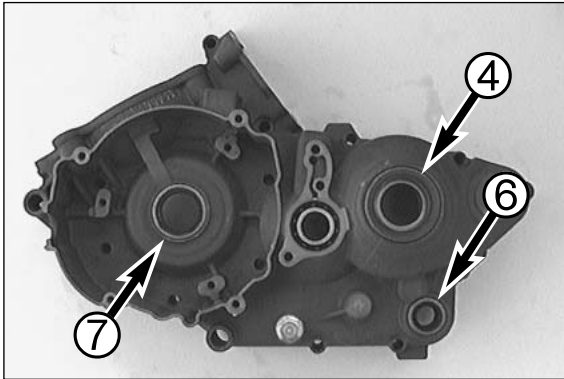

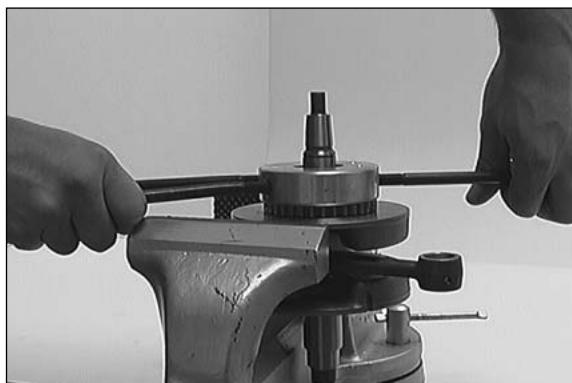

### Crankshaft

- When replacing the roller bearing, the inner crankshaft ring must also be renewed.
- Heat special tool 584.29.037.037 on a heating pad up to approx. 150°C and slip it on the inner ring immediately. Press the special tool together tightly to obtain a good heat transfer and pull the inner ring off the crankshaft.
- To mount the new inner ring, heat the special tool again to approx. 150°C, engage the inner ring and slip it on the crankshaft journal immediately.

### ! CAUTION !

NEVER CLAMP THE CRANKSHAFT WITH A STUD OR WEB IN THE VICE, AND NEVER TRY TO KNOCK THE BEARING INNER RING FREE. THE CRANKSHAFT WEBS MAY BE COMPRESSED AND THE CON-ROD PLUG AND BEARING MAY BE DAMAGED, THEREBY MAKING THE CRANKSHAFT UNUSABLE.

NOTE: Distance adjustment of the main bearings is not required.

- Place the crankshaft on a roller block or similar and using a test gage impact-test the crankshaft journals at their outer ends.

run out of crankshaft journals: max. 0.02 mm (0.0008 in.)

### Crankshaft webs – measure outer dimension

- Crankshaft webs – measure outer dimension with a sliding gauge as illustrated.

Crankshaft webs – outer dimension = 55 mm ± 0.05 mm

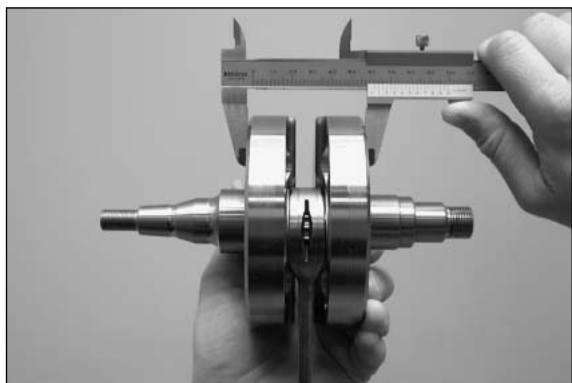

### Piston

If a used piston is to remain in service then the following should be checked:

1. Piston running surface: Check for pressure marks (seizing marks) minor friction marks can be removed with a fine abrasive stick.
2. Piston ring grooves: The piston rings must not get jammed in the grooves. To clean the grooves, use an old piston ring.
3. The piston ring locating pins must be firmly seated in the piston and must not be worn out.
4. Check the piston rings for wear and check the end gap.

- The piston is measured at the piston skirt, transverse to the piston pin 10 mm from the lower edge, as shown in the illustration.
- The smallest cylinder diameter minus the largest piston diameter determines the piston fitting clearance.

Piston fitting clearance

125/144: 0,06 mm

200: 0,055 mm

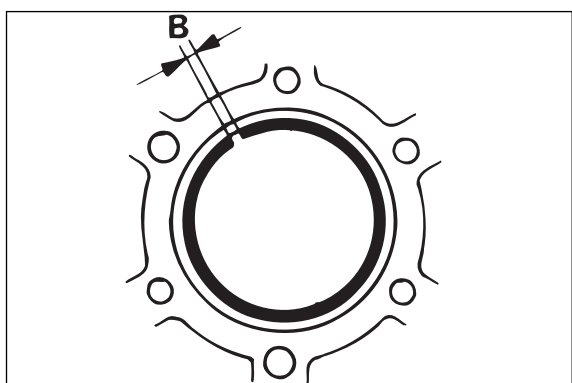

### Piston ring end gap

- Insert the piston ring into the cylinder and adjust it. The piston ring must be approx. 10 mm (0.5 in) from the top of the cylinder.
- The end gap **B** can now be checked with a feeler gauge.

End gap max. 0.40 mm (0.015 in)

NOTE: If the end gap is greater, check the piston and cylinder for wear. If the piston and cylinder wear are within the permitted tolerance limits, replace the piston ring.



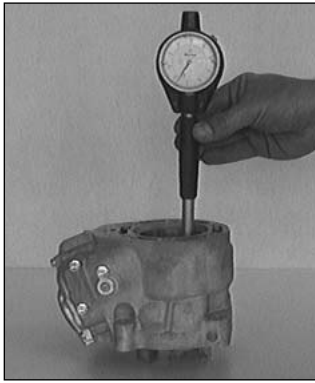
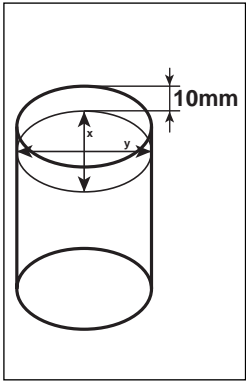

**Checking the cylinder for wear**

Measure the cylinder diameter approx. 10 mm (0.5 in) below the top of the cylinder edge. Check the diameter in several corresponding places to see if the cylinder has worn oval.

Cylinder diameter 125 cm <sup>3</sup> up to Model 2000	Piston size
54,250 - 54,262 mm	.....1
54,263 - 54,275 mm	.....2

Cylinder diameter 125 cm <sup>3</sup> from Model 2001	Piston size
54,000 - 54,012 mm	.....1
54,013 - 54,025 mm	.....2

Cylinder diameter 144 cm <sup>3</sup>	Piston size
56,000 - 56,012 mm	.....1
56,013 - 56,025 mm	.....2

Cylinder diameter 200 cm <sup>3</sup>	Piston size
64,000 - 64,012 mm	.....1
64,013 - 64,025 mm	.....2

If the cylinder diameter is larger than maximum, the cylinder must be replaced.

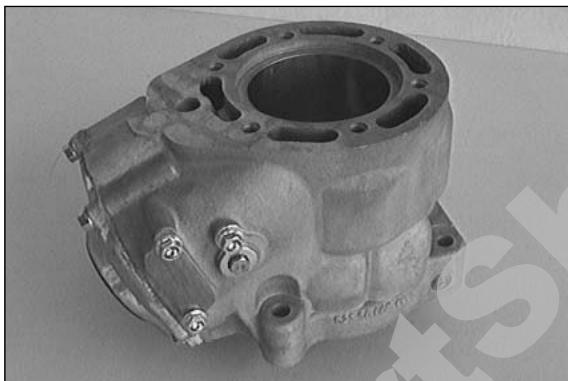
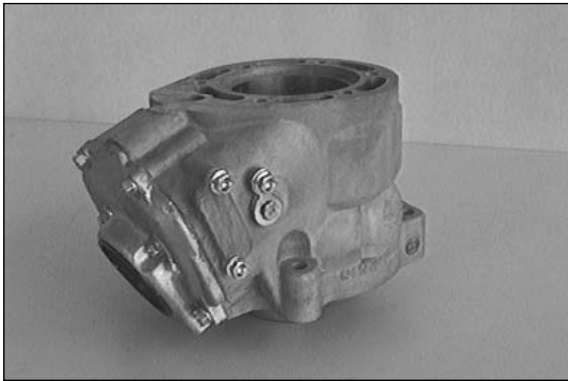

**Nikasil coating of cylinder**

Nikasil is the brand name for a cylinder coating process, developed by the piston manufacturer Mahle. The name is derived from the two materials used in this process - a nickel layer into which the particularly hard silicon carbide is imbedded.

The main advantages of the Nikasil coating are:

- excellent heat dissipation and thus better power output
- low wear
- low weight of the cylinder.

PartsShop.com  
877-999-1886



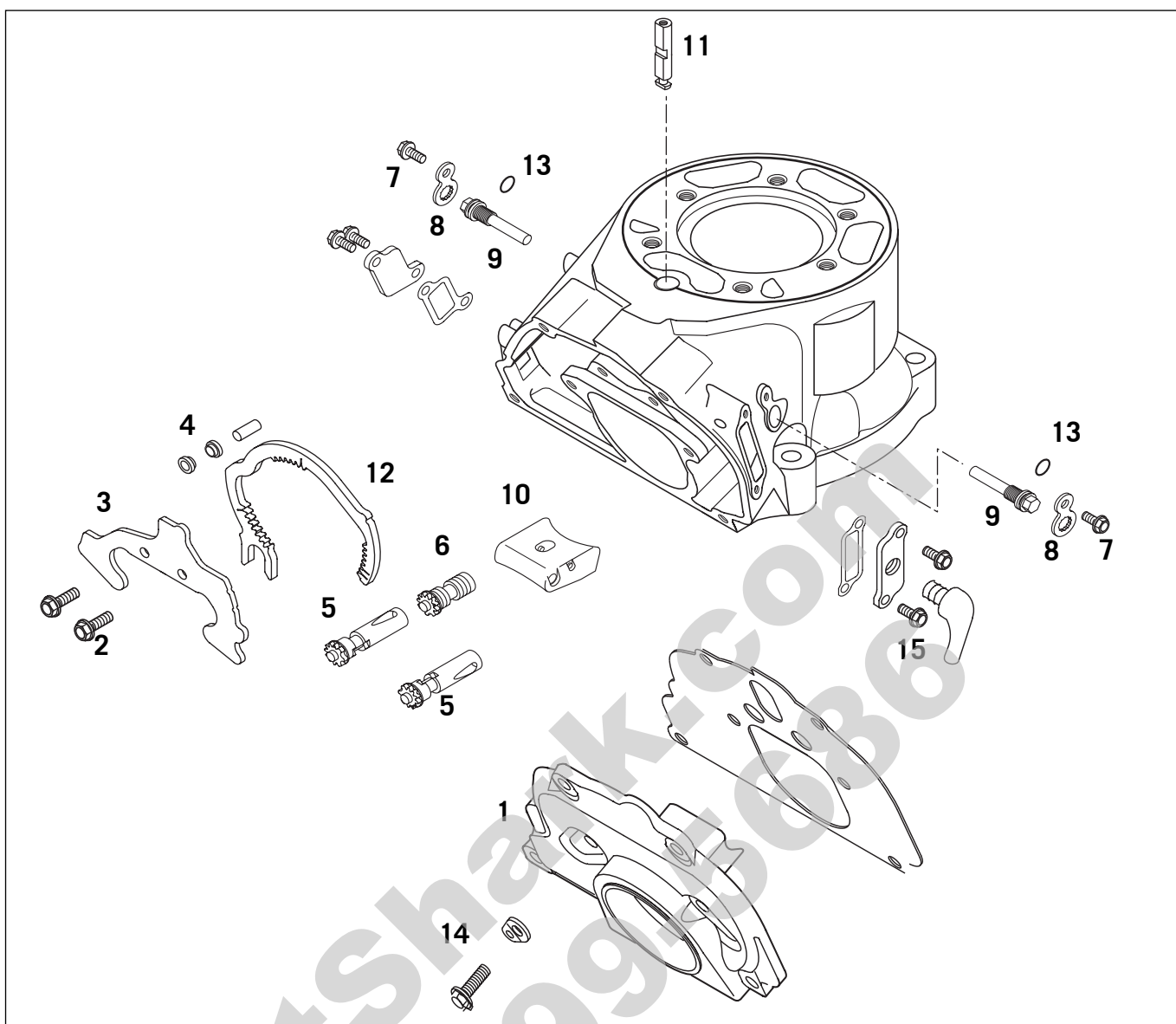

### Dismounting and checking the exhaust control system in the cylinder

- Remove the 6 bolts **14** and take off the exhaust flange **1** together with the gasket.
- Undo the 2 bolts **2** and take the guide plate **3** out of the cylinder.
- Remove the 3 collar bushings **4** and the control segment **12**. To prevent subsequent jamming of the exhaust control, do not damage the bearing surfaces of the collar bushings and the control segment **12**.
- Take the three roller guides **4** behind out of the cylinder.
- Pull the two control rollers **5** and the eccentric shaft **6** out of the bores in the cylinder.
- Undo the bolts **7** to the left and to the right and remove them together with the locking plates **8**.
- Unscrew the left and right control flap axles **9**.
- Slightly push the control flap **10** upwards through the exhaust port. Turn the lifting bolt **11** of the control flap a quarter of a full rotation (it is recommended to screw a M5x40 bolt into the thread of the lifting bolt) and pull it upwards out of the cylinder. Now the control flap can be taken out of the cylinder.
- Clean all parts of the exhaust control and check for wear and damage.

#### Roller guides **4**

Check the contact surface between the roller guides and the control roller segment for grooves and exchange them, if necessary.

#### Control rollers **5**

Check bearing for play.

Check the teeth of the control rollers for wear.

#### Control flap axles **9**

Check the control flap axles for wear (especially at the pins).

NOTE: To prevent sticking of the control flap **10** (125 EXE / 125 Supermoto models), there are nitrogenized control flap axles **9** (bright surface) available which succeed the original fitted axles (dark surface).

#### Control segment **12**

Check the contact surface between the control segment and the roller guides for grooves and exchange them if necessary.

#### O-rings **13**

Check the O-rings of the control flap axles for wear and brittleness and exchange them if necessary.

NOTE: From model 2002 the left side cover **15** is drilled for the crank case ventilation.

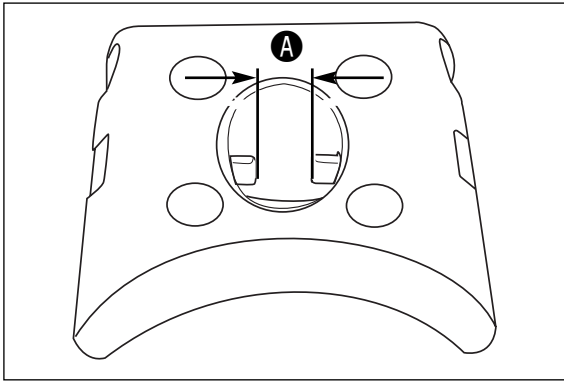
**Control flap 10**

Clean the control flap and check the pins inside for a tight fit. Measure the distance **A** between the two pins (see illustration). When mounted, the control flap must not scrape against the exhaust port.

Distance **A**: min. 5.5 mm (0.22 in)/max. 5.8 mm (0.23 in)

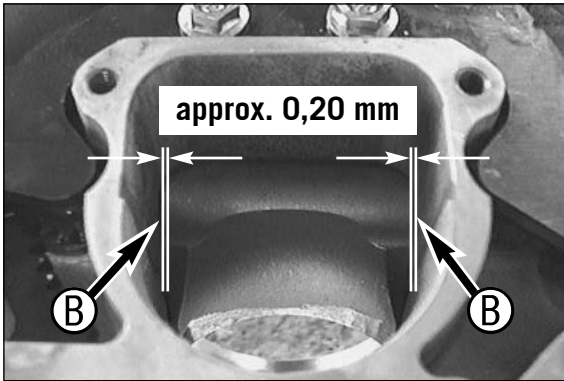
**Preassembling the cylinder**

- Grease the O-rings **10** and control flap axles **9** (especially at the pins).
  - Slide the control flap **10** through the exhaust duct into the cylinder, and position it such that the control flap axles can engage the 2 recesses of the control flap.
  - Mount the left and right control flap axles **9** without tightening them yet.
  - Insert two feeler gauges of identical thickness (approx. 0.20 mm / 0.008 in) between the control flap and the cylinder wall at points **B**. This distance must be equal on both sides.
  - Twist the control flap axles **9** all the way in and then 1/8 of a full turn out again.
  - Apply Loctite 243 to the two bolts **7** and use them to fix the two locking plates **8**, taking care to turn the control flap axles **9** as little as possible.
  - Remove the two feeler gauges and check the control flap for easy operation.
  - When installed, the control flap must not touch the exhaust duct.
- 
- Thoroughly oil the lifting bolt **11** and insert it from above into the bore in the cylinder. Insert the lifting bolt until it engages in the control flap **10**. Then rotate it a quarter of a full turn so that the flat section is perpendicular to the direction of travel and faces forward (in the direction of the exhaust port).
- 
- Thoroughly oil the control rollers **5** and insert them into the bores in the cylinder. Insert the control roller with one mark on the left and the control roller with 2 marks on the right side.
  - Thoroughly oil the eccentric shaft **6** of the control flap and mount it in the cylinder. Move the control flap up and down. The eccentric shaft should move with the control flap.

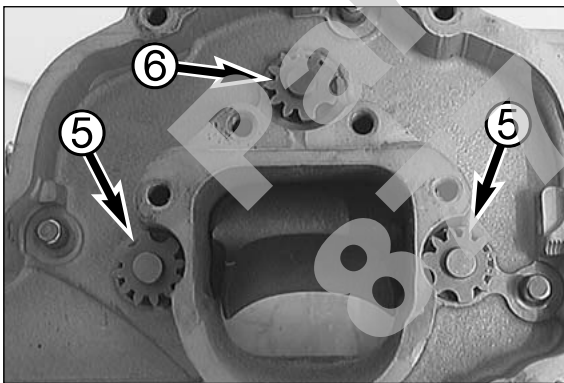
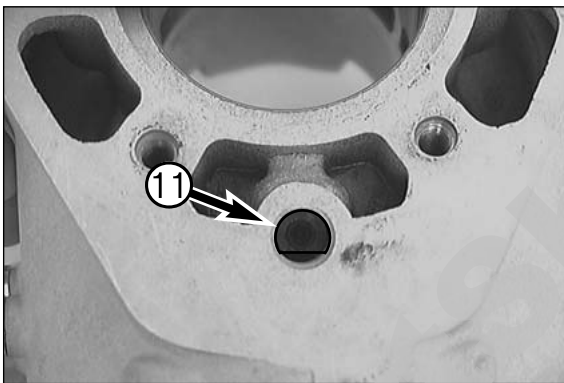

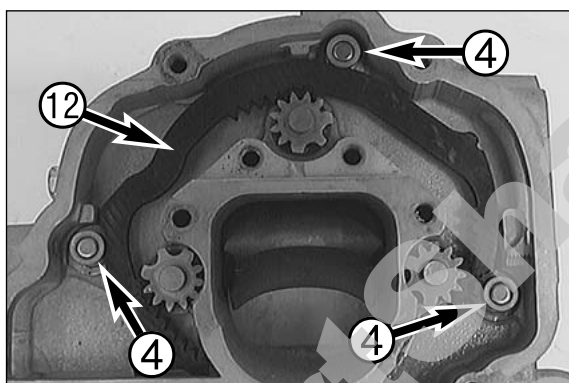
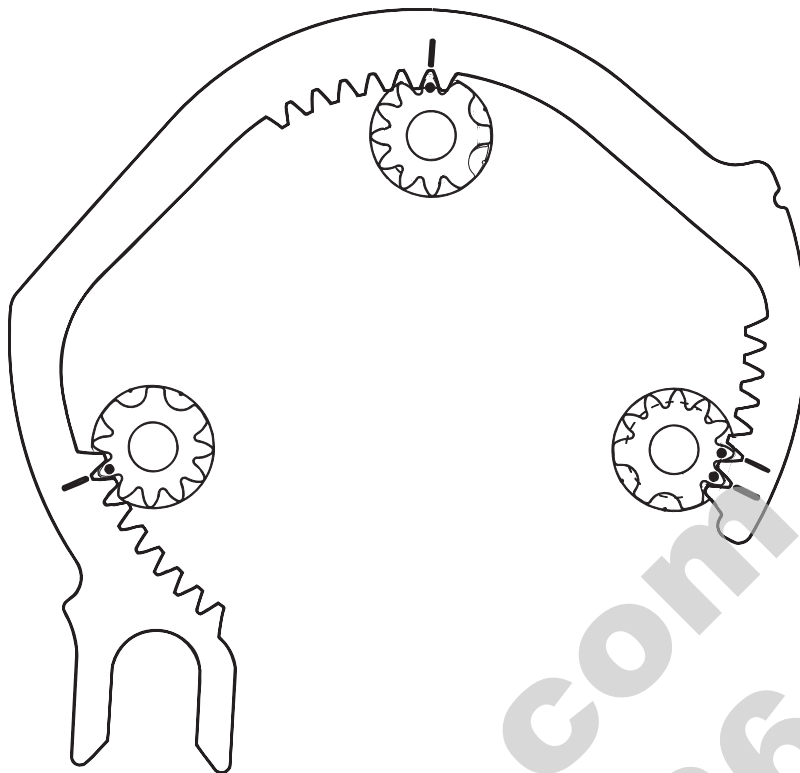

- Grease the pins in the cylinder and mount the 3 roller guides **4** with the large collar facing the cylinder.
- Turn the control rollers and the adjusting roller of the control flap so that the marks are on the outside (facing the control segment).
- Mount the control segment **12** in such a way that the marks on the control rollers coincide with those of the control segment (see illustration).

NOTE: When all marks are aligned, the control flap must be in the bottom position and the bores of the control rollers must be completely closed.

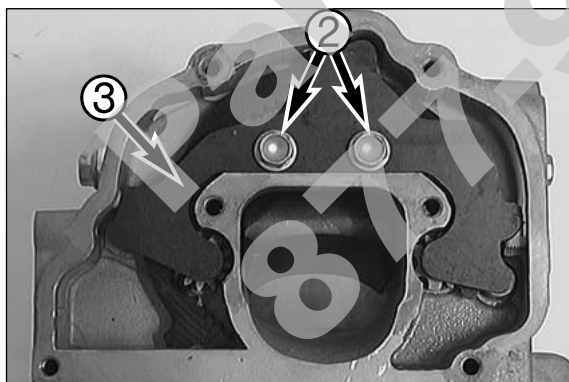

- Mount the three roller guides **4** with the small collar facing the cylinder.
- Mount the guide plate **3**, apply Loctite 243 to the two bolts **2** and use them to fix the guide plate in the cylinder.
- Turn the control segment clockwise. The control flap must open and the bores of the control rollers must be opened.

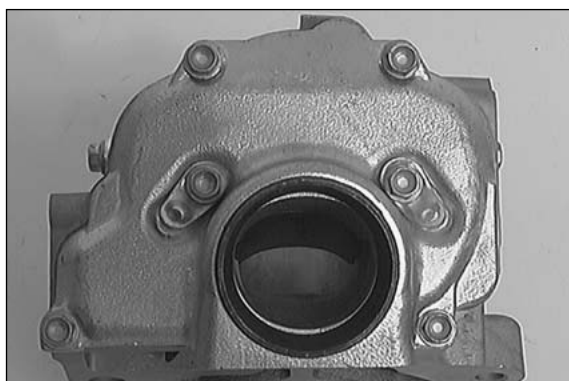

- Mount a new gasket.
- Fix the cover with the six bolts. Don't forget the 2 brackets for the exhaust springs.
- Finally, check the exhaust control system for easy operability

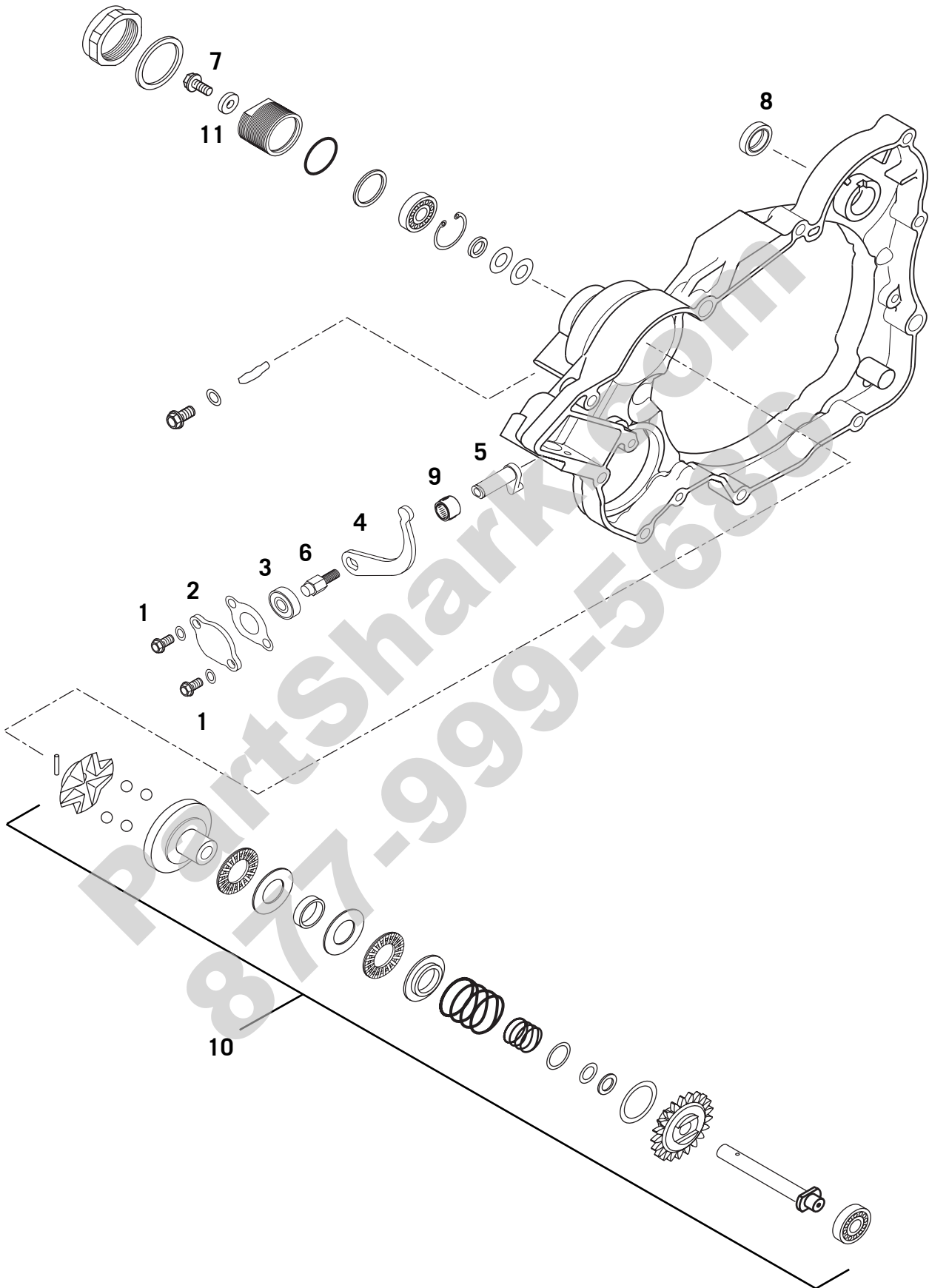

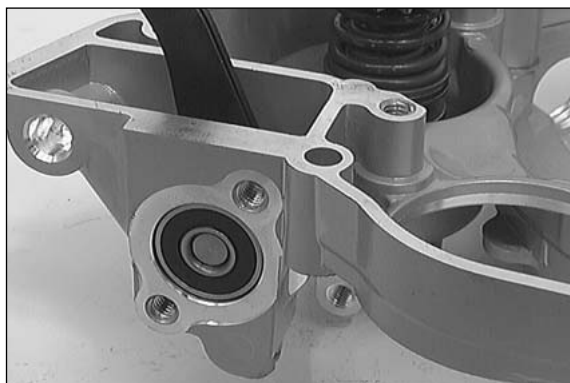

### Dismounting the exhaust control system in the clutch cover and checking parts for wear

- Undo the 2 bolts ① and remove the closure cap ② together with the gasket and the copper seal rings.
- Press the grooved ball bearing ③ below out of the clutch cover. To do this, push the rocker arm ④ of the centrifugal timer forward (in the direction of the grooved ball bearing).

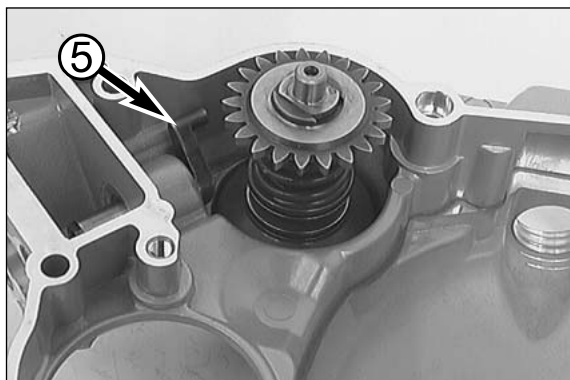

- Turn the adjusting lever ⑤ so that it rests against the clutch cover (see illustration).
- Undo the bolt ⑥ and pull the rocker arm ④ off the adjusting lever ⑤.
- Undo the collar bolt ⑦ of the centrifugal timer ⑩ and pull the centrifugal timer inwards out of the clutch cover.
- Pull the adjusting lever ⑤ out of the clutch cover.
- Clean all parts and check for wear.

#### Adjusting the lever ⑤

Check the pins of the adjusting lever for wear. Check the bearing surface between the adjusting lever and the needle bushing for wear.

#### Grooved ball bearing ③

Check for wear.

#### Needle bushing of the adjusting lever ⑨

The bearing bushing of the adjusting lever normally shows no signs of wear. If this is nevertheless the case, it is recommended to replace the entire clutch cover.

#### Shaft seal ring of the kickstarter shaft ⑧

Lever the used shaft seal ring out of the clutch cover with a screwdriver.

Grease the new shaft seal ring and insert it with the open side facing inwards. Press it in flush.

#### Centrifugal timer ⑩

The centrifugal advance device is factory-preset and must not be disassembled.

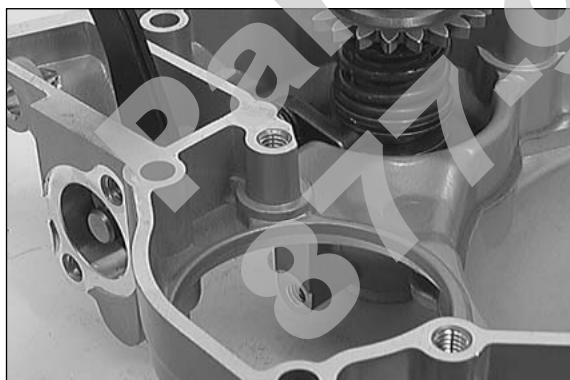
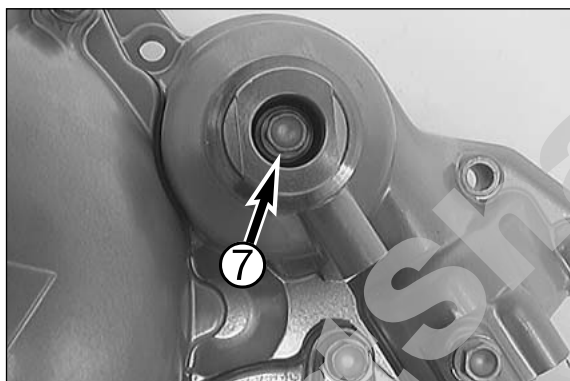

### Preassembling the clutch cover

- Grease the bearing ⑨ of the adjusting lever, insert the adjusting lever ⑤ into the clutch cover and let it rest against the clutch cover (see illustration).
- Fix the centrifugal timer with the bolt in the clutch cover. Secure the bolt with Loctite 243.

NOTE: The bolt ⑦ is tightened after mounting the clutch cover.

- Hook the pins of the adjusting lever ⑤ into the track of the centrifugal timer.
- Mount the rocker arm ④ on the adjusting lever ⑤ and fix it with the bolt.
- Insert the grooved ball bearing with the open side of the cage facing inwards into the clutch cover.
- Mount the cover ② with a new gasket and new copper gaskets.

! **CAUTION** !

WHEN MOUNTING THE COVER ②, MAKE SURE THAT THE FLAT SECTION A IS CORRECTLY ALIGNED TO PREVENT DAMAGING THE CLUTCH COVER.

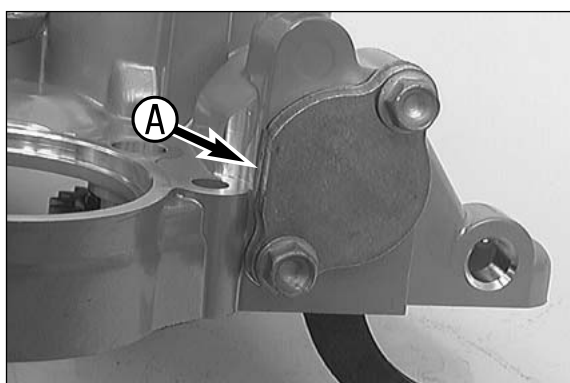



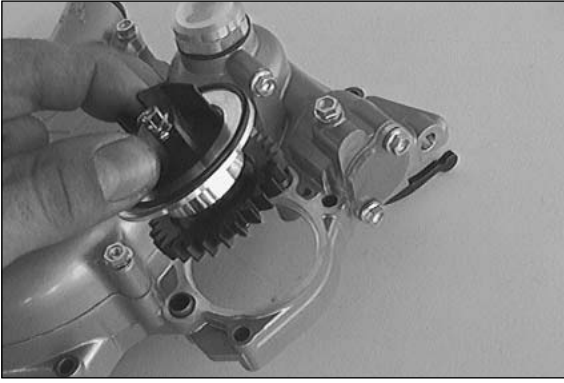

### Disassembling and checking the water pump

- Remove the 2 bolts of the water pump cover and take the cover off.
- Pull the water pump and the O-ring out of the clutch cover.
- Clamp the water pump with the water pump wheel facing upwards into the vise (use protective jaws).

! **CAUTION** !

TO PREVENT DAMAGING THE WATER PUMP DRIVING WHEEL, NEVER CLAMP THE WHEEL ITSELF INTO THE VISE.

- Remove the collar bolt ❶ together with the washer.
- Pull the water pump wheel ❷ upwards off the water pump shaft ❸.
- Take the water pump shaft out of the vise and pull the water pump shaft out of the housing ❹.

#### Shaft seal ring of the water pump shaft ❸

Use a screwdriver to lever the shaft seal ring out of the water pump housing.

Apply Loctite 648 to the outside of the new shaft seal ring and press it into the housing with the label facing inwards.

#### Grooved ball bearing of the water pump shaft ❹

The shaft seal ring ❸ must be removed to exchange the grooved ball bearing. Use an appropriate mandrel to press the grooved ball bearing out of the water pump housing ❹.

Press a new grooved ball bearing all the way into the seat. Apply Loctite 648 to the outside of a new water pump shaft seal ring and insert it with the label facing inwards.

#### Water pump driving wheel ❷

The water pump driving wheel should not turn on the water pump shaft.

Check the teeth of the water pump driving wheel for wear.

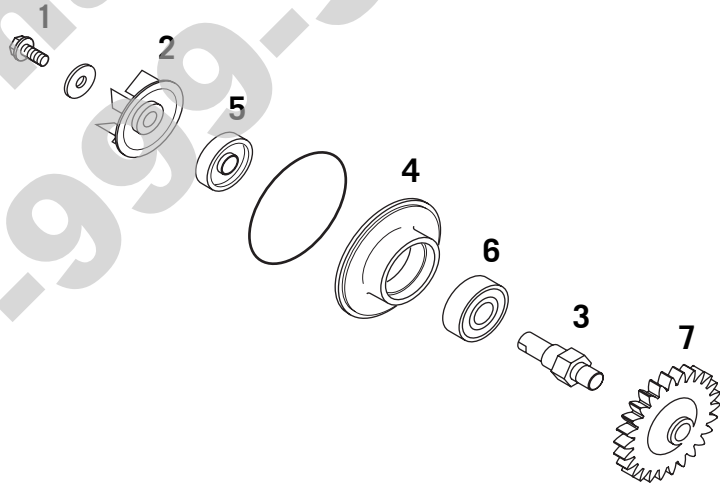
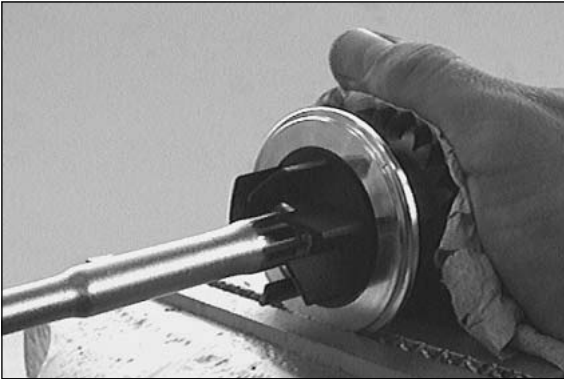

### Preassembling the water pump

- Grease the shaft seal ring ❸ and the grooved ball bearing ❹ of the water pump shaft, and insert the water pump shaft into the water pump housing ❹.
- Clamp the water pump shaft into the vise (use protective jaws).

! **CAUTION** !

TO PREVENT DAMAGING THE WATER PUMP DRIVING WHEEL, NEVER CLAMP THE WHEEL ITSELF INTO THE VISE.

- Put the water pump wheel ❷ on the shaft, apply Loctite 243 to the bolt ❶ and mount the bolt and washer.
- Place preassembled water pump and new O-ring into the clutch cover.
- Fix the water pump cover with 2 short bolts.

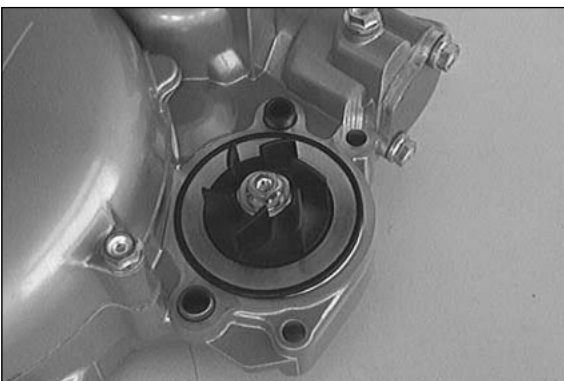

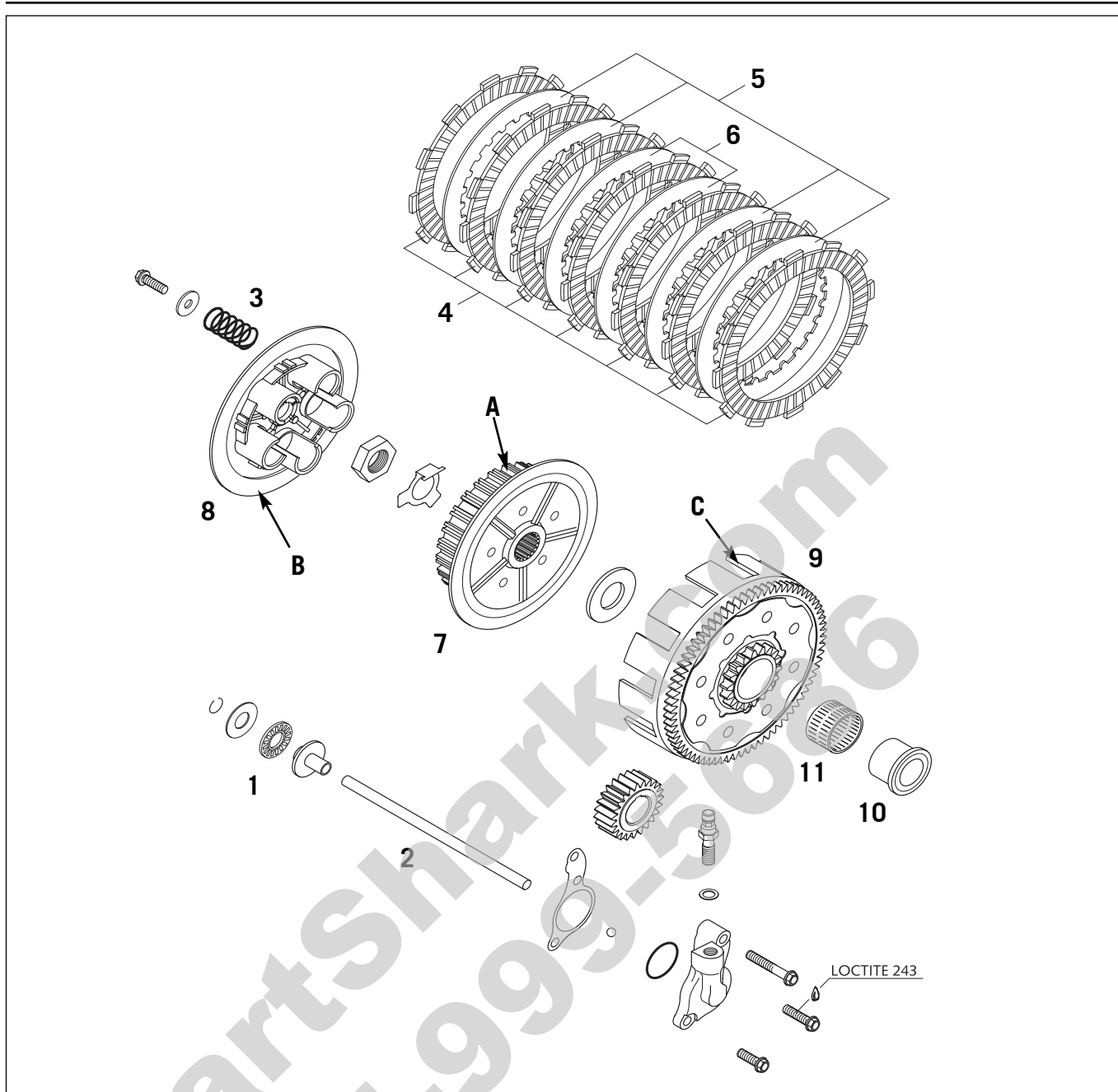

### Checking the clutch for wear

Thrust bearing ① - check it for score marks and easy operability.

Push rod ② - place it on a flat surface check and check for bends.

Clutch springs ③ minimum length: 38 mm up to model 2005 (new length 39 mm); if necessary exchange all 5 springs.  
39 mm as of model 2006 (new length 40 mm); if necessary exchange all 5 springs.

7 Lining discs ④ - minimum thickness: 2.9 mm (new 3,0 mm). Discs must be plane.

4 Clutch discs - aluminium ⑤ - discs must be plane; check for mechanical damage.

2 Clutch discs - steel ⑥ - discs must be plane; check for mechanical damage.

Inner clutch hub ⑦ - check the bearing surface of the lining disc for damage.

Check the bearing surfaces ① of the steel discs at the inner clutch hub. If the grooves are deeper than 0.5 mm replace the inner clutch hub.

Pressure cap ⑧ - check the bearing surface ② of the lining disc for damage.

Outer clutch hub ⑨ - check the stop faces ③ of the lining discs for wear. The outer clutch hub must be replaced if the grooves are more than 0.5 mm deep (see below).

Mount the inner ring ⑩ and the needle cage ⑪, check for play.

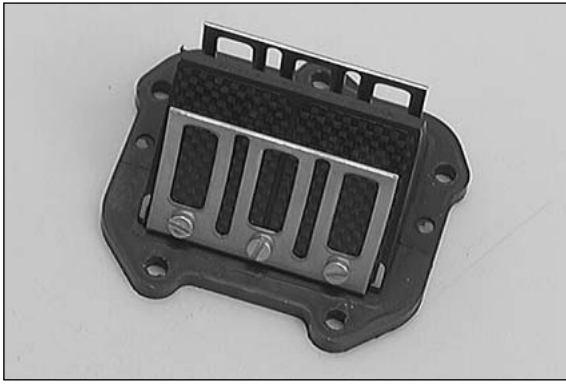

### Reed valve housing, intake flange

NOTE: The reed paddles ① + ⑥ slowly lose their tension during operation, thus reducing the overall performance. Damaged or worn reed paddles must therefore be replaced.

The entire reed valve housing must be exchanged if the sealing surfaces of the reed valve housing ② are also damaged.

!

#### CAUTION

!

WHEN MOUNTING THE REED VALVE HOUSING BE SURE TO APPLY LOCTITE 243 TO ALL BOLTS.

Velocity insert ③

Check for tight fit and damage.

Intake flange ④

Check for cracks and other damage.

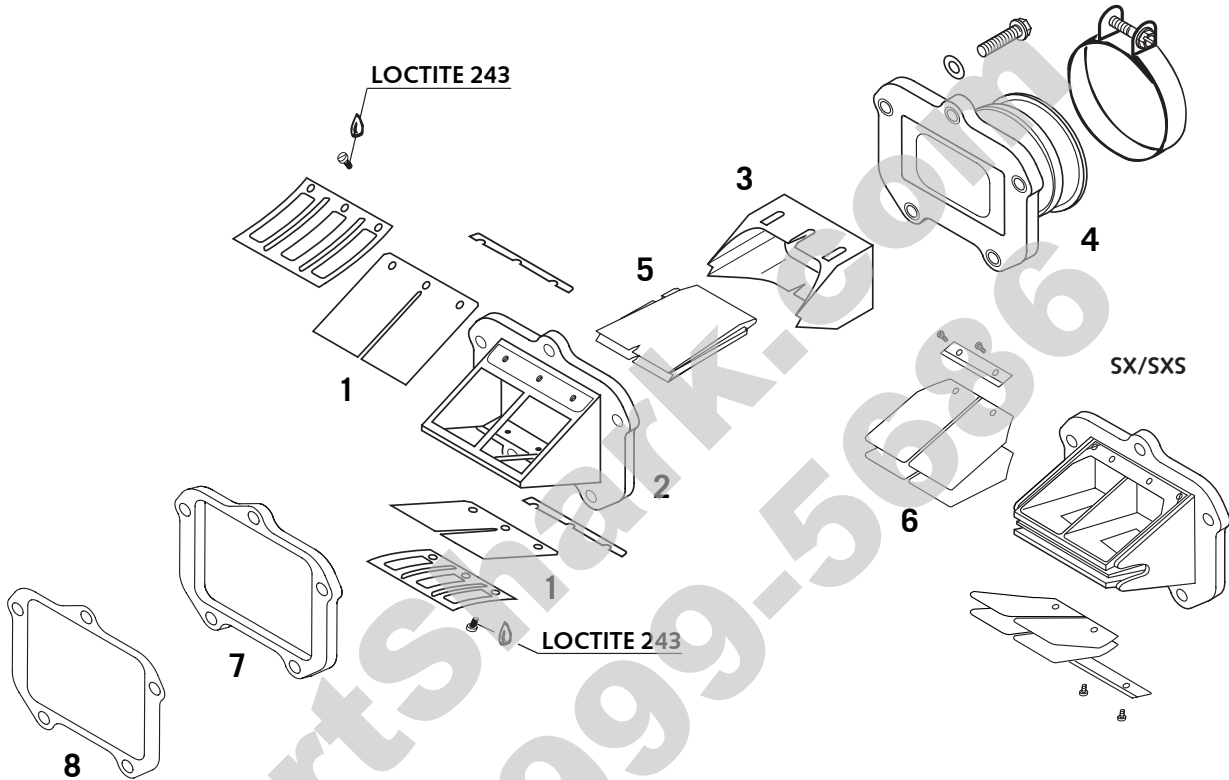

#### NOTE:

- Model 2000 onwards velocity insert ③ and wing ⑤ is only available as one part.
- No components are available for SX/SXS models from 2004 except for the reed paddles ⑥.
- A reed valve plate ⑦ is installed between the gasket ⑧ and reed valve housing ② in 200 cc engines from model 2006 onwards.

- Measure distance  $M$  between the stop plates with a sliding gauge (not applicable to the SX/SXS from the 2004 model onwards).

Distance  $M$  = 28 mm

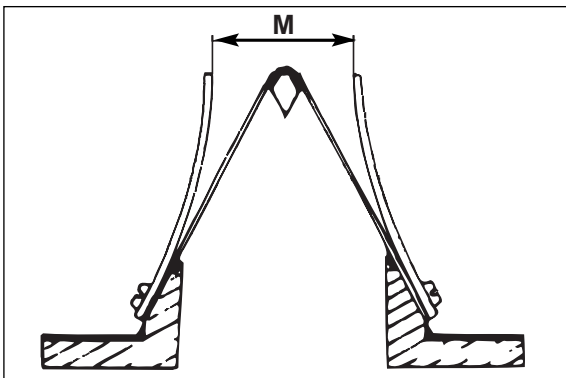



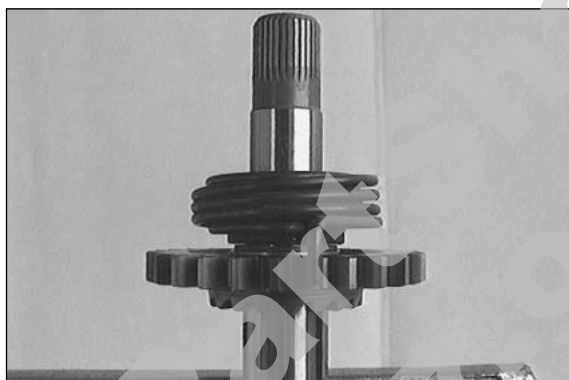
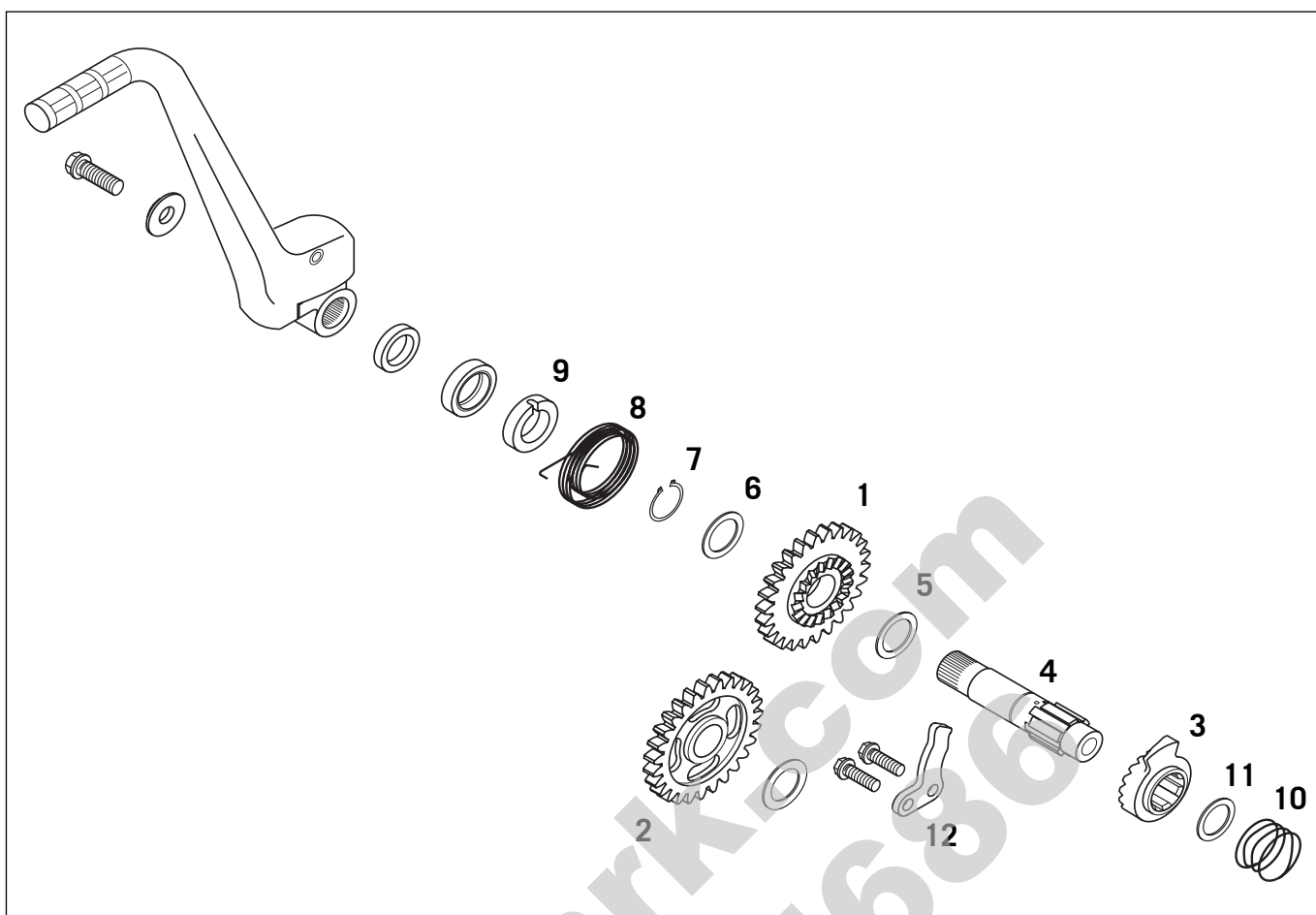

### Kickstarter

Take all components off the kickstarter shaft and clean them.

#### Kickstarter gear ①

Check the bearing for play and grooves.

#### Intermediate kickstarter gear ②

Check the bearing for play and grooves.

#### Locking pawl ③

Check for wear and damage.

#### Kickstarter shaft ④

Check for wear and damage, paying particular attention to pivot points and teeth. Check the lubrication bores for free passage.

### Preassembling the kickstarter shaft

- Mount the locking pawl on the kickstarter shaft. Ensure that the mark **A** on the locking pawl coincides with the bore **B** in the kickstarter shaft.
- Clamp the kickstarter shaft **4** into the vise (use protective jaws) with the teethed end facing upwards.
- Mount the stop disc **5** (17x24x1 mm) and the kickstarter gear **1** with the ratchet teeth facing downwards.
- Put the stop disc **6** (17x24x1 mm) on the shaft.
- Mount the circlip **7** with the sharp edges facing upwards.
- Mount the kickstarter spring **8**; insert the inner end of the kickstarter spring into the bore of the kickstarter shaft.
- Mount the driving hub **9**; the slot must be positioned above the inner end of the kickstarter spring.
- Take the kickstarter shaft out of the vise.
- Mount the ratchet gear spring **10** and the stop disc **11** on the kickstarter shaft.

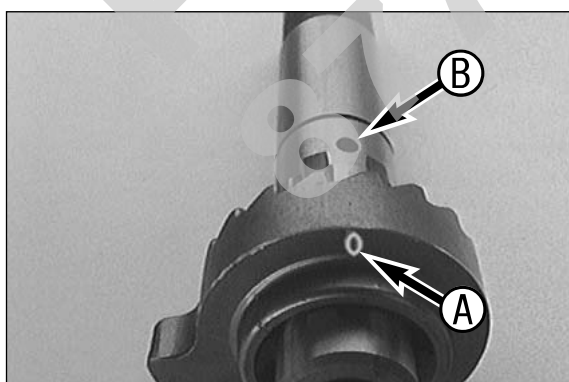

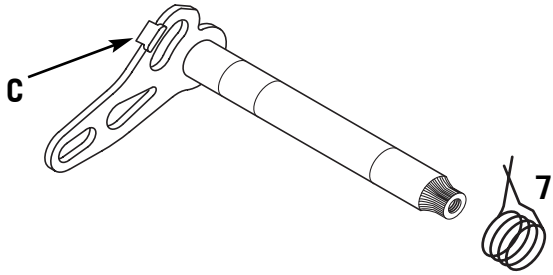

Shifting mechanism from model 2001 on

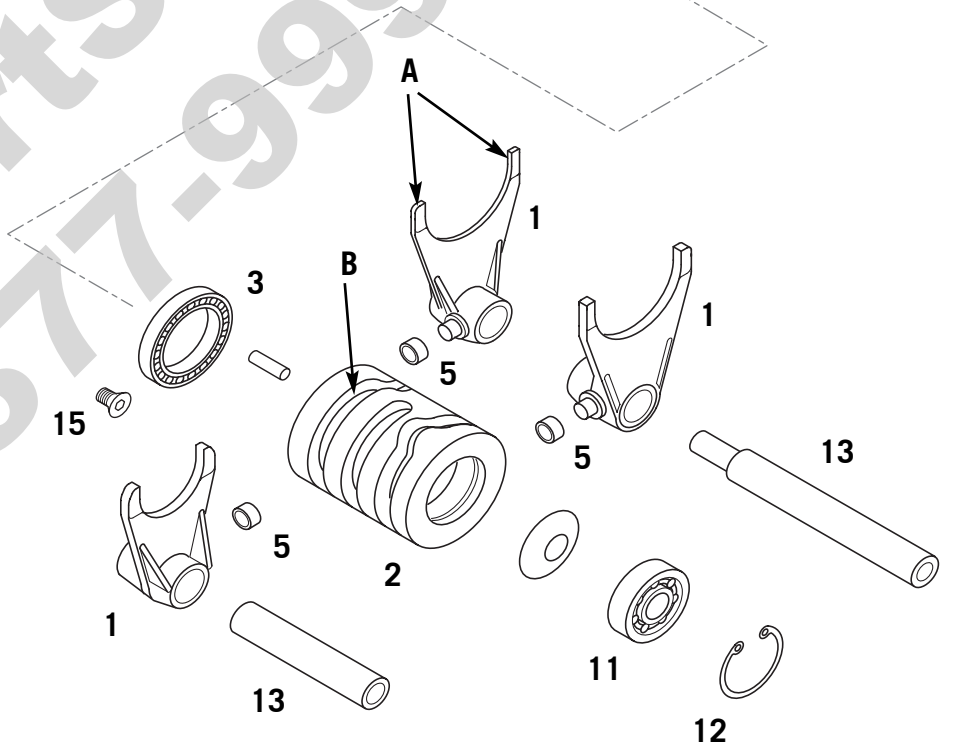
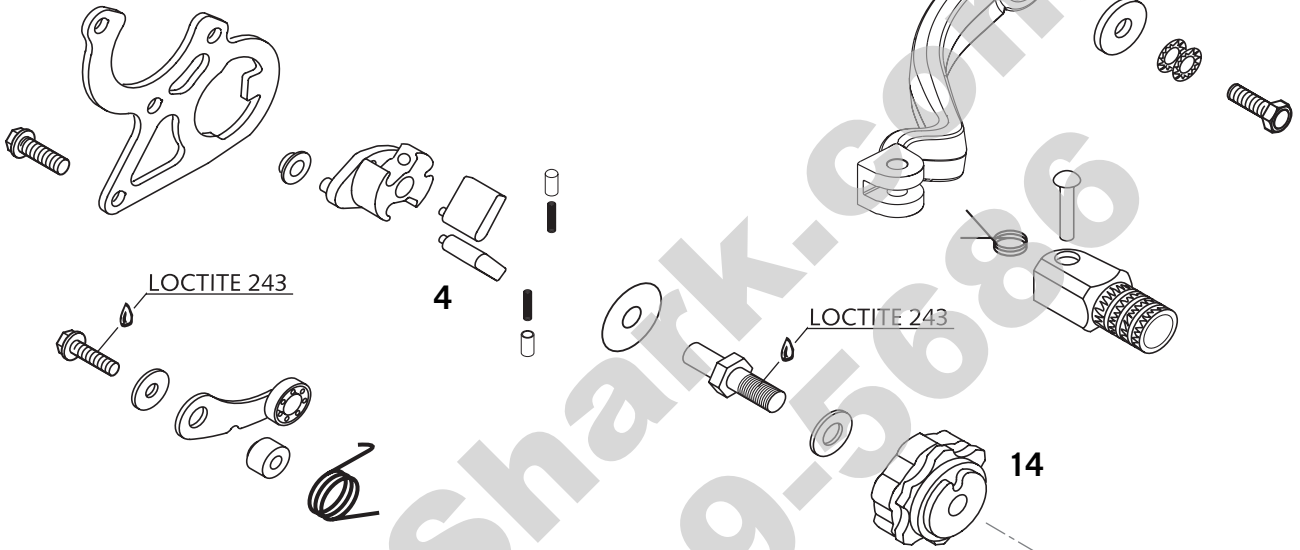
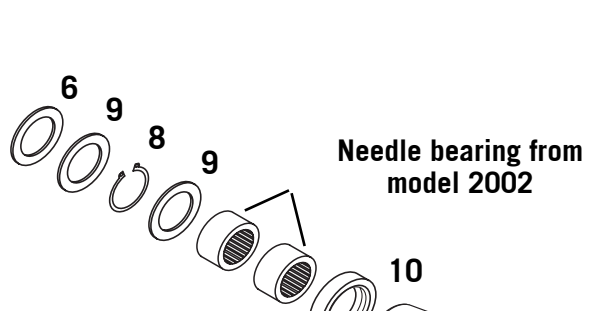

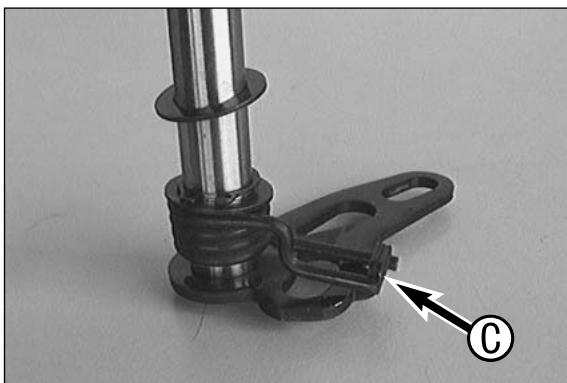

### Shifting mechanism

#### Shift forks ①

Check the blade ④ for wear.

#### Shift roller ②

Check the shift grooves ③ for wear.

Ensure that the shift roller rests properly in the grooved ball bearing ⑤. Check the grooved ball bearing ⑥ in the shift roller for wear. To replace it, remove the Seeger circlip ring ⑦ and pull the grooved ball bearing out of the shift roller (slide seat). Mount the Seeger circlip ring with the sharp edge pointing to the outside.

#### Shift ratchet ④

Check the contact surface toward the gear shifting gate for wear. The shift ratchets must not jam when mounted.

#### Grooved ball bearing ⑤

Check for smooth operation.

#### Sleeves ⑤ up to model 2002

The driving pin for the shift shaft must be free of pressure marks.

#### Shift rails ⑬

Impact-test the shift rails on a planar surface. Check shift rails for score and seizing marks. The easy operability of the shift forks on the shift rails must be ensured.

### Preassembling the shifting shaft (up to model 2000)

- Grease the 2 stop discs ⑥ (14,3x20x1 mm), and slide them onto the shift shaft.
- Mount the return spring ⑦ on the shift shaft; the two legs of the spring must rest against bracket ⑧ of the shift shaft.
- Put the disc ⑨ (14,3x20x1 mm) on the shaft, then mount the circlip ⑩ with the sharp edge facing upwards in the groove of the shift shaft.
- Put on the disc ⑨ (14,3x20x1 mm).

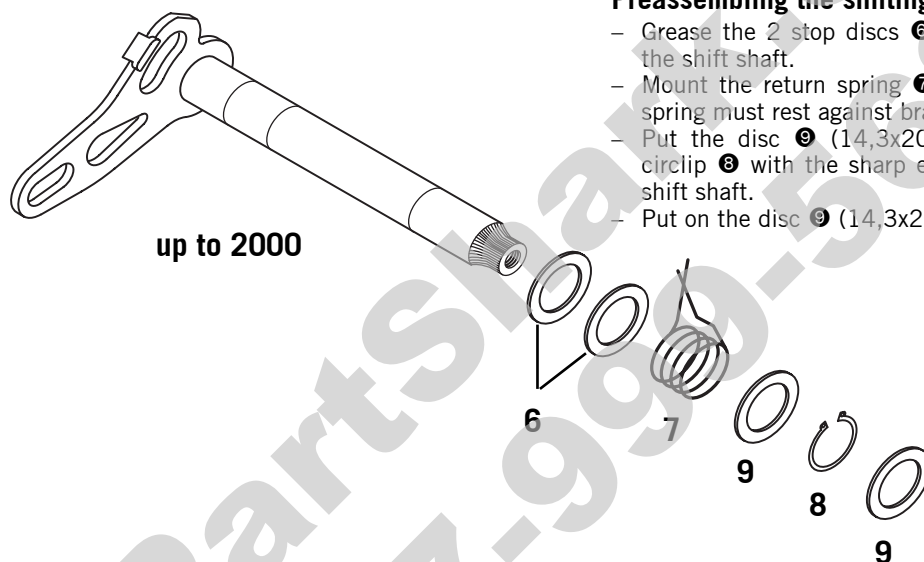

### Preassembling the shifting shaft (model 2001 onwards)

- Mount the return spring ⑦ on the shift shaft; the two legs of the spring must rest against bracket ⑧ of the shift shaft.
- Put discs ⑥ (14,2x22x1,5 mm) and ⑨ (14,3x20x1 mm) on the shaft, then mount the circlip ⑩ with the sharp edge facing upwards in the groove of the shift shaft.
- Put on the disc ⑨ (14,3x20x1 mm).

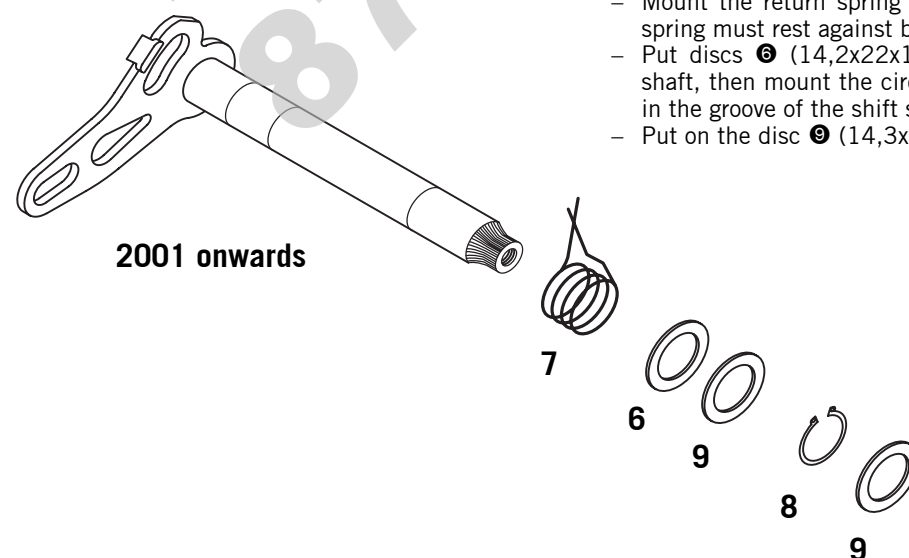

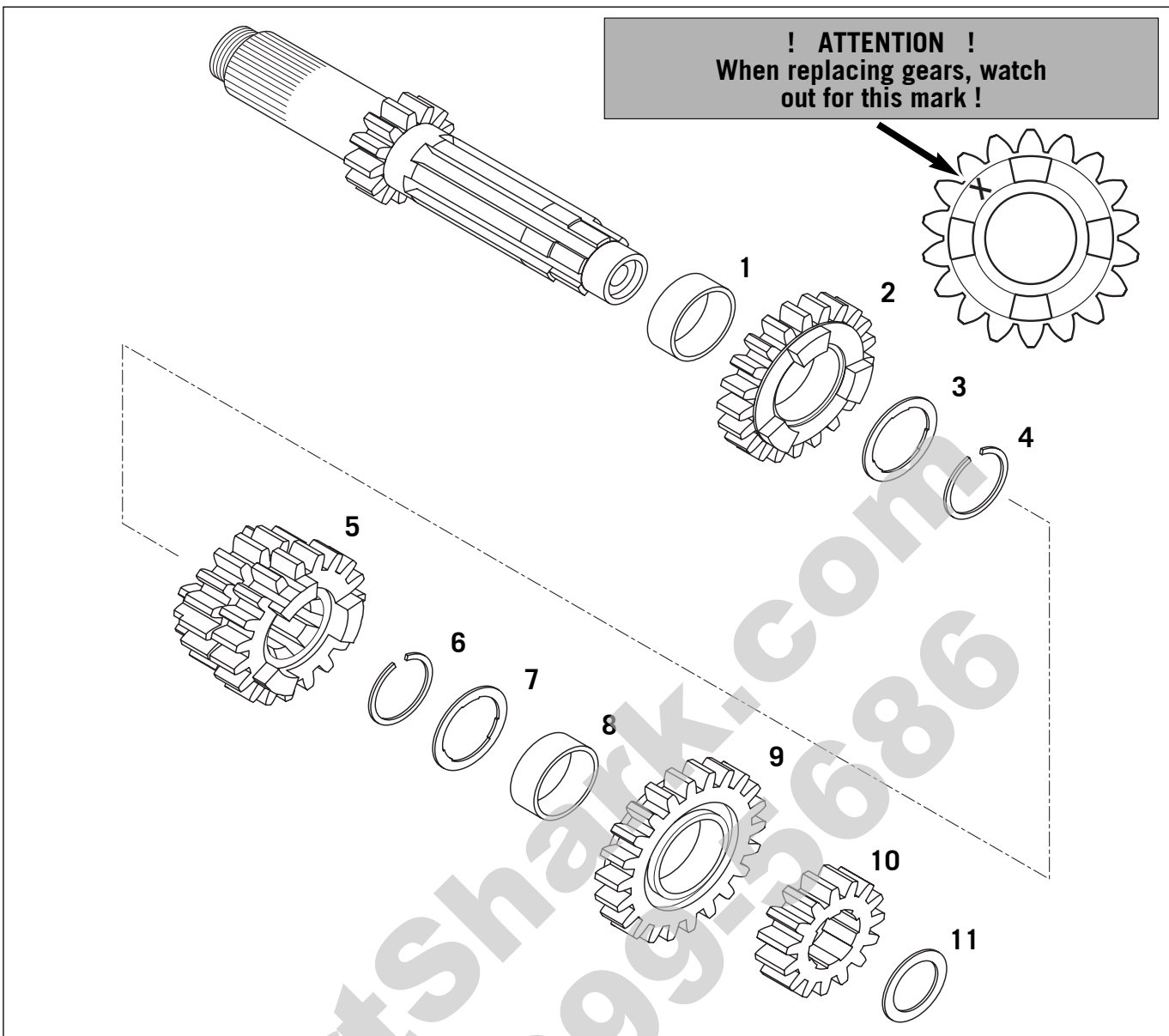

### Transmission

Clamp the main shaft or countershaft respectively, into the vise (use protective jaws). Remove the gears and check the following parts for wear and grooves:

- Bearing sleeves
- Pivot points of the main shaft and countershaft and pivot points of the idler gears
- Shift dogs of the gears
- Tooth faces of all gears
- Tooth profiles of the main shaft and countershaft as well as of the corresponding gears
- Check the profiles of all control gears for smooth operation

Thoroughly clean all parts and exchange damaged components. New axial securing elements should be mounted whenever repair work is performed.

### Assembling the main shaft

- Clamp the main shaft into a vise (use protective jaws) with the toothed end facing downwards.
- Carefully grease all parts before mounting them.
- Mount the bearing sleeve ① (22x25x11.1 mm) on the main shaft. Then put the 5<sup>th</sup> idler gear ② on the shaft with the shifting claws facing upwards.
- Put the stop disc ③ (22.2x27.8x1 mm) onto the shaft and mount the axial securing element ④.
- Mount the 3<sup>rd</sup>/4<sup>th</sup> sliding gear ⑤ with the small gear facing downwards and mount the axial securing element ⑥.
- Put the stop disc ⑦ (22.2x27.8x1 mm) onto the shaft.
- Mount the bearing sleeve ⑧ (22x25x11.1 mm) and the 6<sup>th</sup> idler gear ⑨ with the recess for the shifting claws facing downwards.
- Mount the 2<sup>nd</sup> fixed gear ⑩ and the stop disc ⑪ (17.2x26x1 mm).
- Then check all gears for smooth operation.

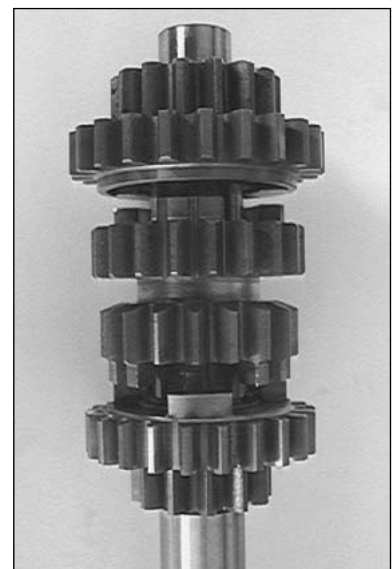

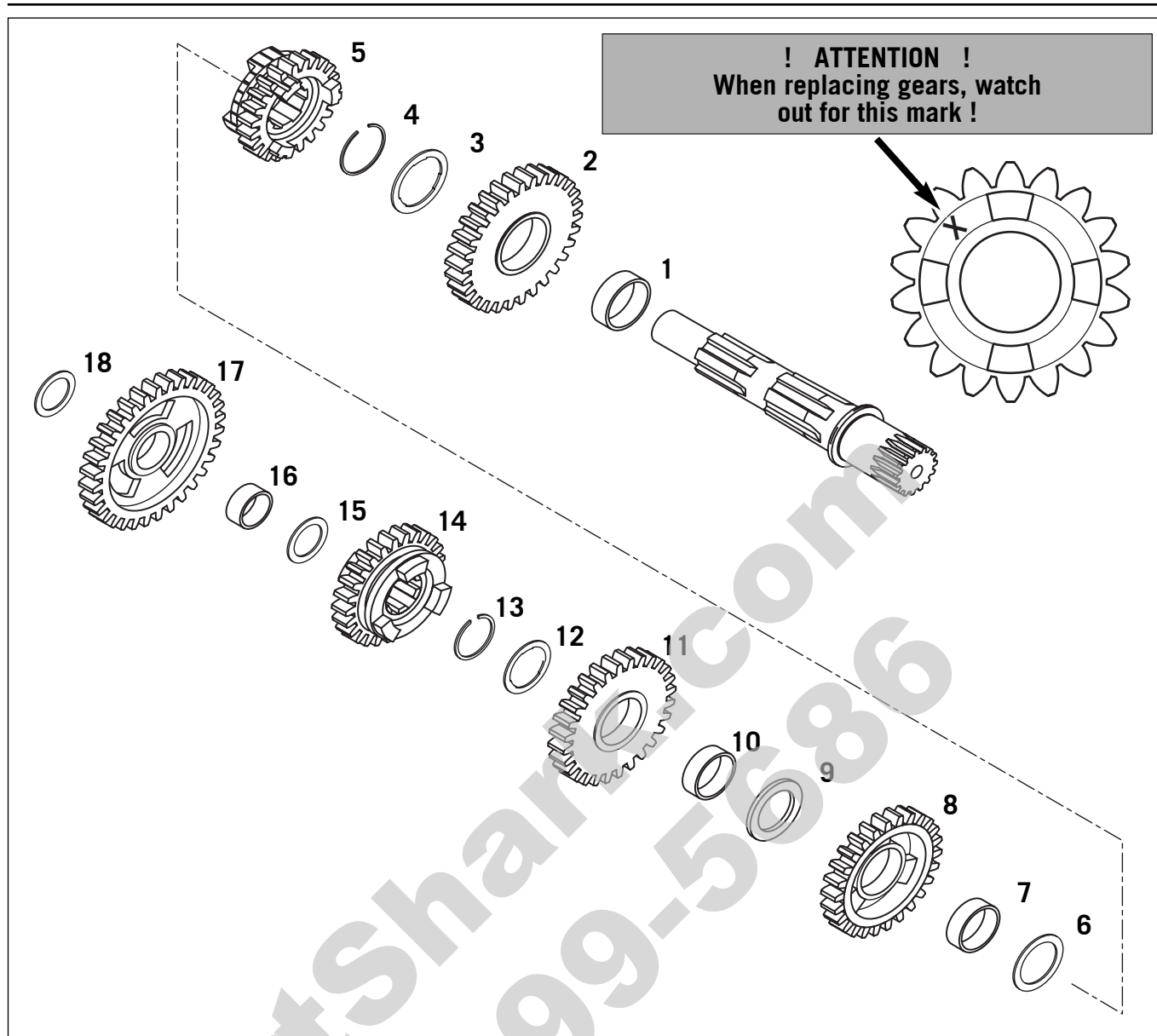

## Transmission

Clamp the main shaft or countershaft respectively, into the vise (use protective jaws). Remove the gears and check the following parts for wear and grooves:

- Bearing sleeves
- Pivot points of the main shaft and countershaft and pivot points of the idler gears
- Shift dogs of the gears
- Tooth faces of all gears
- Tooth profiles of the main shaft and countershaft as well as of the corresponding gears
- Check the profiles of all control gears for smooth operation

Thoroughly clean all parts and exchange damaged components. New axial securing elements should be mounted whenever repair work is performed.

## Assembling the countershaft

- Clamp the countershaft into the vise (use protective jaws!) with the toothed end facing downwards.
- All parts must be carefully greased before mounting.
- Mount the bearing sleeve ① (25x28x9.7 mm) and the 2<sup>nd</sup> idler gear ② with the recess for the shifting claws facing upwards.
- Mount the stop disc ③ (25.2x32x1 mm) and the axial securing element ④ on the countershaft.
- Mount the 6<sup>th</sup> idler gear ⑤ with the shift groove facing upwards, then mount the stop disc ⑥ (22.2x28x1 mm).
- Mount the bearing sleeve ⑦ (22x25x8.1 mm), the 4<sup>th</sup> idler gear ⑧ and the stop disc ⑨ (22.2x30x2.5 mm).
- Mount the bearing sleeve ⑩ (22x25x8.1 mm), the 3<sup>rd</sup> idler gear ⑪, the stop disc ⑫ (22.2x27.8x1 mm) with internal teeth and the axial securing element ⑬.
- Mount the 5<sup>th</sup> sliding gear ⑭ with the shift groove facing downwards and the stop disc ⑮ (17.2x26x1 mm).
- Mount the bearing sleeve ⑯ (17x20x9.7 mm), the 1<sup>st</sup> idler gear ⑰ with the collar facing upwards and the stop disc ⑱ (17.2x26x1 mm).





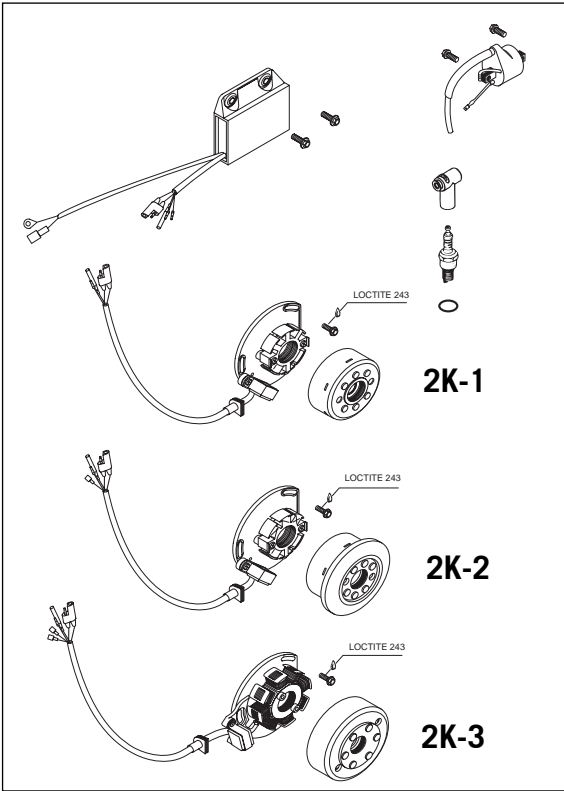

**Ignition**

**General information**

The measurements described below will only reveal severe problems. Coil short circuits leading to weak ignition sparks or low generator output respectively, can only be detected with the help of an ignition test bench. In the case of malfunction always check the cables and the plug and socket connections of the ignition system first.

Make sure to select the correct measuring range when performing measurements.

The CDI unit can be checked only on the ignition test bench.

**Spark plug**

Electrode distance: see Technical Specification

Insulator

Check for cracks and fissures.

**! CAUTION !**

ALWAYS USE A SPARK PLUG WITH RESISTOR. OTHERWISE PROBLEMS CAN OCCUR IN THE CDI UNIT.

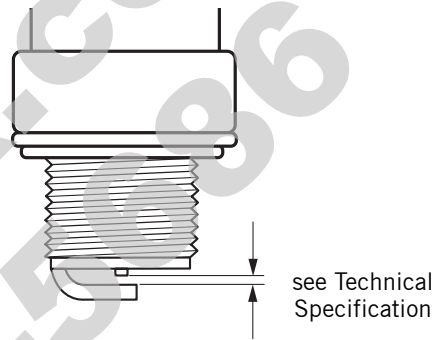

**Check stator and pulse generator**

Use an ohmmeter to perform the following measurements:

Ignition	Measure	cable colours	Resistance
2K-1	Pulser coil	red – green	100 Ω ± 20%
	Exciter	black/red – red/white	24,8 Ω ± 20%
2K-2	Pulser coil	red – green	100 Ω ± 20%
	Exciter	black/red – red/white	24,8 Ω ± 20%
	Charge coil	ground – yellow	0,74 Ω ± 20%
2K-3	Pulser coil	red – green	100 Ω ± 20%
	Exciter	black/red – red/white	12,7 Ω ± 20%
	Charge coil	ground – yellow	0,65 Ω ± 20%
		white – yellow	0,16 Ω ± 20%

NOTE: The measuring must be performed at a temperature of 20° C. Otherwise significant deviations must be expected. Replace the stator and/or the pulse generator if the measured values deviate significantly from the setpoint values.

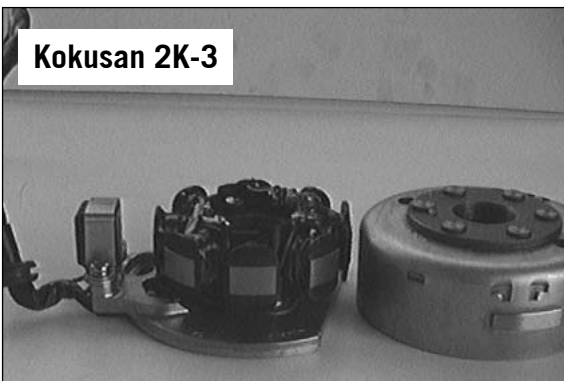
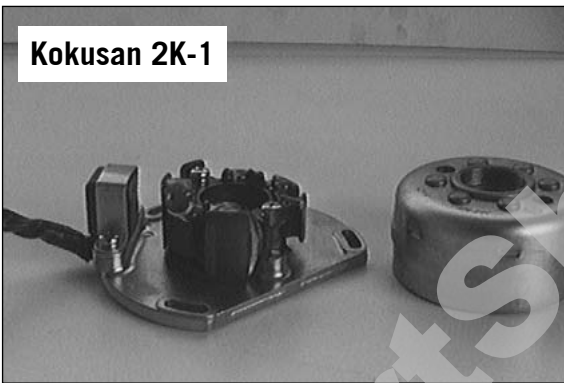

# ASSEMBLING THE ENGINE

# 6

## INDEX

<b>MOUNTING THE CRANKSHAFT</b> .....	<b>6-2</b>
<b>TRANSMISSION AND SHIFT MECHANISM</b> .....	<b>6-2</b>
<b>ASSEMBLING THE ENGINE HOUSING</b> .....	<b>6-3</b>
<b>ENGINE SPROCKET</b> .....	<b>6-3</b>
<b>IGNITION SYSTEM</b> .....	<b>6-3</b>
<b>SHIFT DRUM LOCATING DEVICE</b> .....	<b>6-4</b>
<b>KICKSTARTER</b> .....	<b>6-5</b>
<b>PRIMARY DRIVE AND CLUTCH</b> .....	<b>6-5</b>
<b>CLUTCH DISCS AND PRESSURE CAP</b> .....	<b>6-6</b>
<b>OIL PUMP, REED VALVE HOUSING AND INTAKE FLANGE (SEPARATE LUBRICATION)</b> .....	<b>6-7</b>
<b>CLUTCH COVER</b> .....	<b>6-8</b>
<b>REED VALVE HOUSING AND INTAKE FLANGE</b> .....	<b>6-8</b>
<b>PISTON AND CYLINDER</b> .....	<b>6-9</b>
<b>ADJUSTING DIMENSION "X"</b> .....	<b>6-9</b>
<b>ADJUSTING THE CONTROL FLAP (DIMENSION "Z")</b> .....	<b>6-10</b>
<b>CYLINDER HEAD</b> .....	<b>6-10</b>
<b>IGNITION COVER</b> .....	<b>6-11</b>
<b>MEASURING DIMENSION "Y"</b> .....	<b>6-11</b>
<b>MOUNTING THE CLUTCH SLAVE CYLINDER</b> .....	<b>6-12</b>
<b>REFILLING THE GEAR OIL</b> .....	<b>6-12</b>

**PartShark.com**  
**877-999-5686**



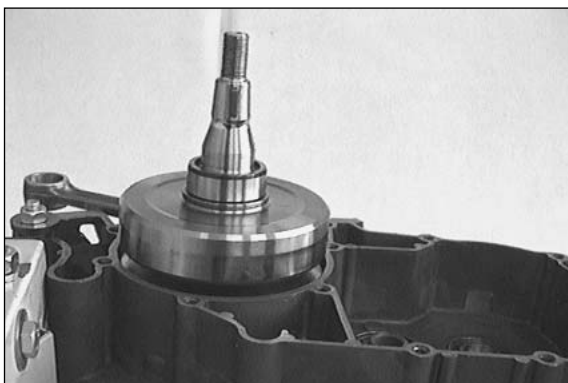

- Clamp the right housing half onto the mounting rack.

### Mounting the crankshaft

- Oil the grooved ball bearing of the crankshaft.
- Insert the crankshaft into the grooved ball bearing from above and carefully push it as far as it will go.

**! CAUTION !**

THE CONROD MUST BE DIRECTED TOWARDS THE CYLINDER WHEN THE CRANKSHAFT IS INSERTED!

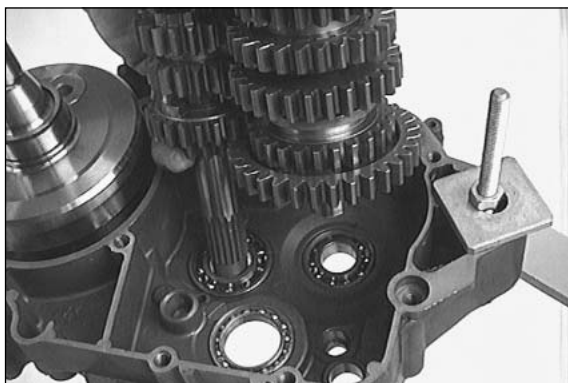

### Transmission and shift mechanism

- Mount the stop disc at the bottom of the countershaft and fix it with grease to prevent it from slipping off the shaft.
- Align the teeth of the main shaft and the countershaft and insert both shafts together into the bearing seats.

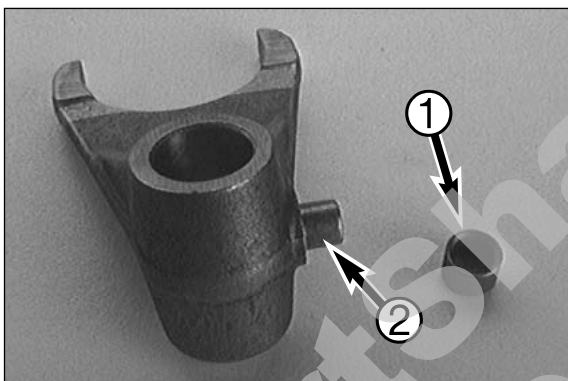

up to model 2002:

- Grease the driving pins ② of the shift forks and mount the rollers ①.

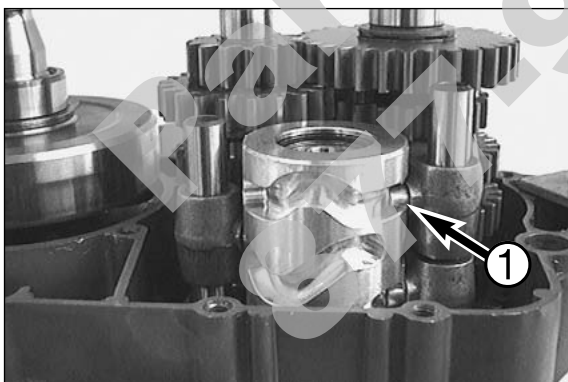

- Oil the blades of the shift forks and hook them into the sliding gears.
- Insert the shift roller into the bearing seat and hook the shift forks into the shift roller.
- Oil the shift rails and insert them into the shift forks (short rail facing the main shaft).

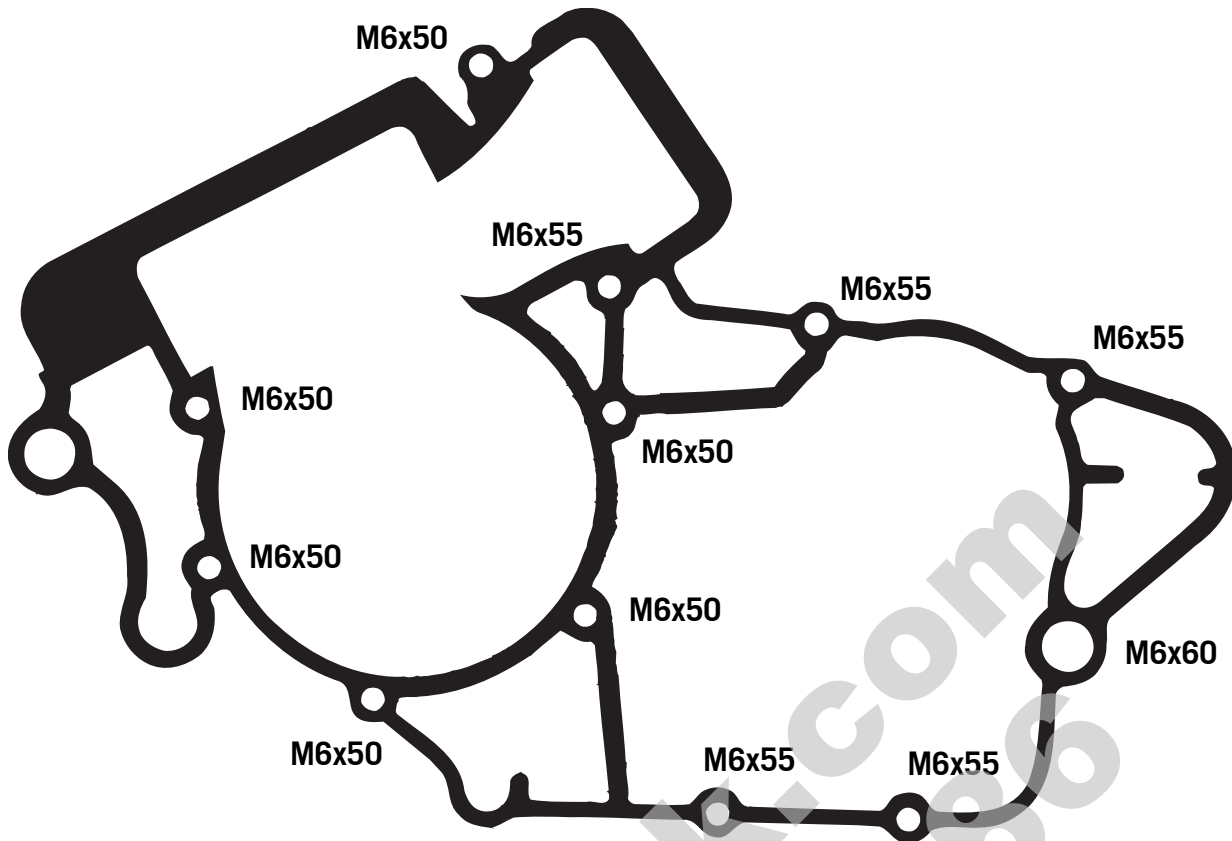

### Assembling the engine housing

- Remove the engine holder at the mounting rack.
- Make sure that both dowels are properly located in the right housing half.
- Slightly grease the sealing surface of the housing and mount a new gasket.
- Make sure that the rubber is properly inserted into the left housing half and that the sleeves have not slipped off the driving pins of the shift forks.
- Grease the shaft seal rings of the left housing half and put on the left housing half.
- Check the housing gasket for proper fit.
- Grease the threaded sections and the contact surfaces at the heads of the housing bolts. Insert the bolts and assemble the housing (bolt lengths are indicated in the illustration).
- Check all shafts for easy operation before and after tightening the housing bolts.
- Fix the engine on the mounting rack.
- Cut the protruding gasket off cleanly at the sealing surfaces of the cylinder base and the reed valve housing.

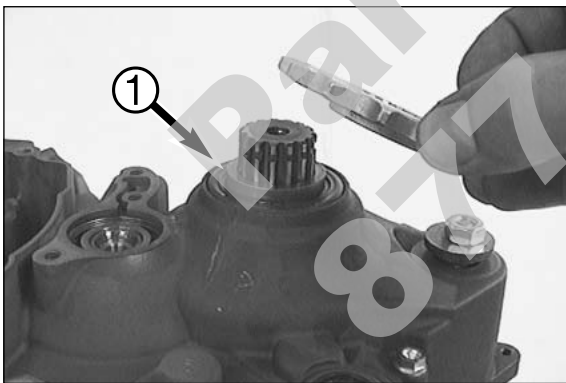

### Engine sprocket

- Oil the O-ring and put it on the countershaft.
- Mount the distance bushing ① in such a way that the O-ring is located in the chamfer.
- Put the chain sprocket onto the countershaft with the collar facing inwards and fix it with the circlip (sharp edge outwards).
- Tap the chain sprocket with a hollow mandrel or a similar tool to slightly pretension the O-ring and to press the circlip into the groove.

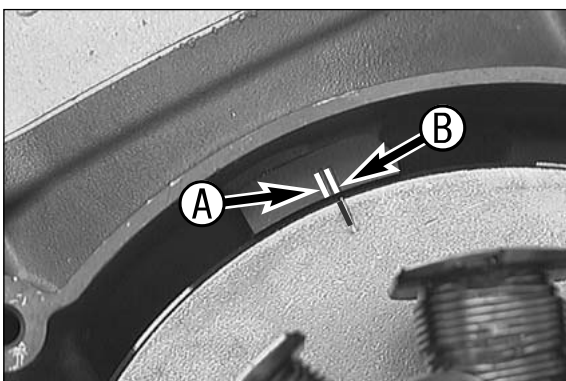

### Ignition system

- Insert the woodruff key into the crankshaft.
- Apply Loctite 243 to the thread of the bolt and fix the stator in the housing with the 3 bolts without yet tightening them.
- Turn the stator so that mark of the stator coincides with the middle mark of the housing. Then tighten all three bolts of the stator.

NOTE: The left-hand mark **A** in the housing is intended for the 2K-1 and 2K-2 ignition systems. The right-hand mark **B** in the housing is meant for the 2K-3 ignition system.

- Insert the cable guide into the housing.

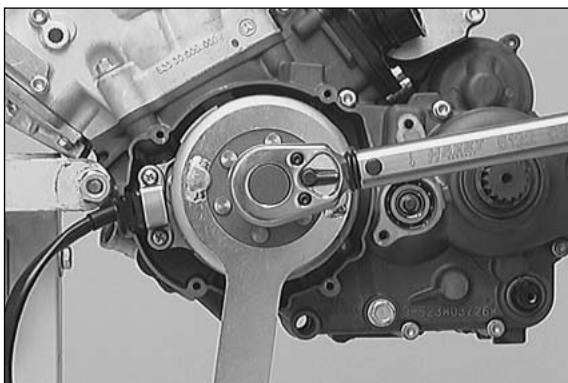

- Mount the rotor.
- Mount the detent edged ring and the nut.
- Hold the rotor with the holding spanner and tighten the hexagon nut with 60 Nm / 44 ft.lb.).

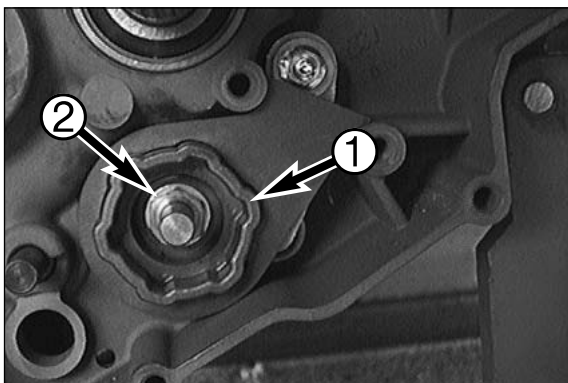

### Shift drum locating device

- Mount the locking drum ① on the shift roller. Keep in mind that the pin of the shift roller must engage in the corresponding recess of the locking drum.
- Slide the washer onto bolt ②, apply Loctite 243 on its thread and mount the bolt. Block the locking drum with a special tool (see picture), and tighten the bolt.

! **CAUTION** !

THE LOCKING DRUM MUST BE HELD WITH THE SPECIAL TOOL TO PREVENT DAMAGING THE BUSHINGS ON THE DRIVING PINS OF THE SHIFT FORKS.

NOTE: If the locking lever hasn't been removed, push it sideways against the resistance of the spring when mounting the locking drum.

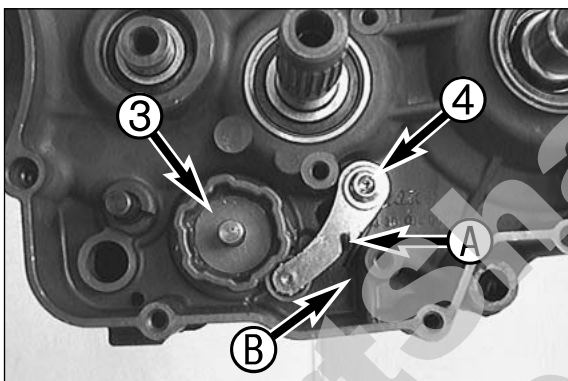

- Mount washer ③.
- Line the washer, the locking lever, the collar bushing (the small collar facing the head of the bolt) and the locking spring on bolt ④. Hook the end A of the locking spring into the locking lever.
- Apply Loctite 243 to bolt ④ and use it to fix the locking lever. Make sure that the other end of the locking spring rests against the housing bracket B.

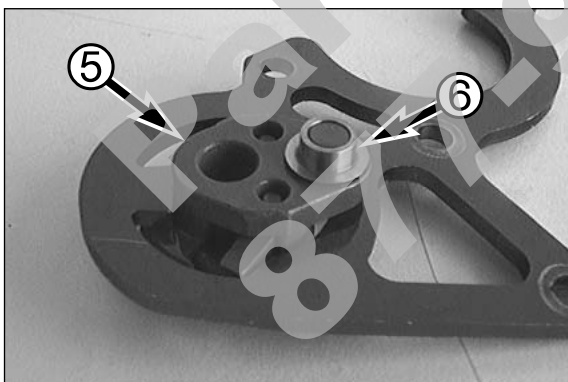

- Insert the ratchet carrier ⑤ into the gear shifting gate as shown in the illustration.
- Use a small quantity of grease to fix the collar bushing ⑥ on the ratchet carrier.

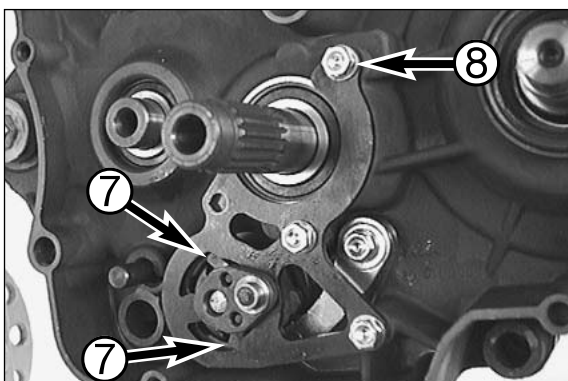

- Mount the ratchet carrier together with the gear shifting gate in the housing. The ratchets ⑦ must be slightly squeezed to insert the ratchet carrier into the locking drum.
- Fix the gear shifting gate with 3 bolts ⑧ on the housing.

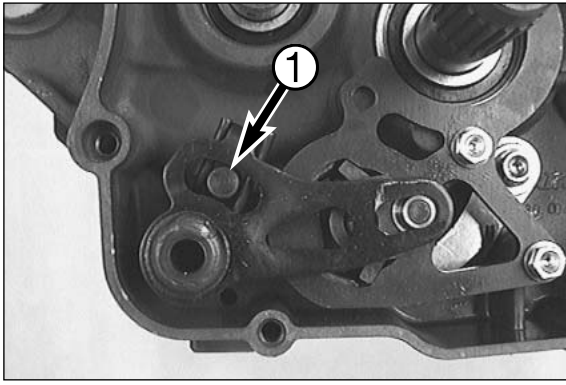

- Grease the shaft seal ring of the shift shaft.
- Oil the shift shaft and insert it into the housing. Do not forget the stop disc! When mounting the shift shaft make sure that both legs of the return spring rest against the prolongation of the shift rail ❶.

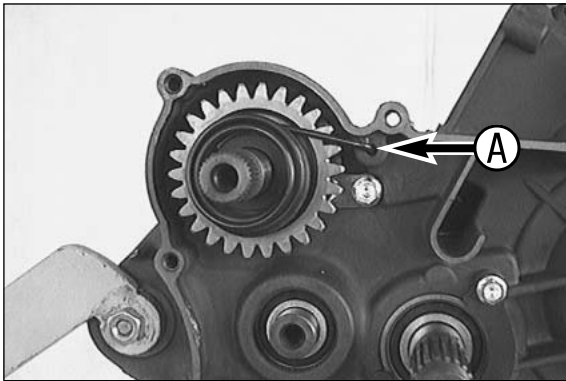

### Kickstarter

- Grease the bearing bore of the kickstarter shaft in the housing.
- Insert the preassembled kickstarter shaft into the housing so that the locking pawl is located on the kickstarter shaft behind the release plate in the housing.
- Pretension the kickstarter spring clockwise and hook it into the corresponding bore in the housing A.

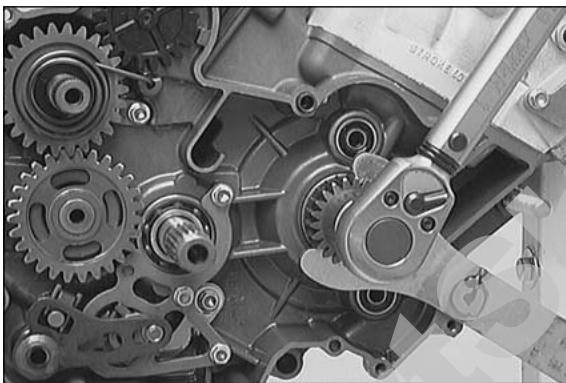

### Primary drive and clutch

- Grease the shaft seal ring of the crankshaft.
- Put the oiled O-ring (25x2 mm) onto the crankshaft and mount the distance bushing with the chamfer facing the crank web so that the O-ring is located in the chamfer.
- Insert the woodruff key into the crankshaft.
- Put the primary gear onto the crankshaft with the collar facing the housing.
- Mount a new detent edged ring and a hexagon nut (LH thread).
- Mount the holding spanner for the primary gear and tighten the hexagon nut.

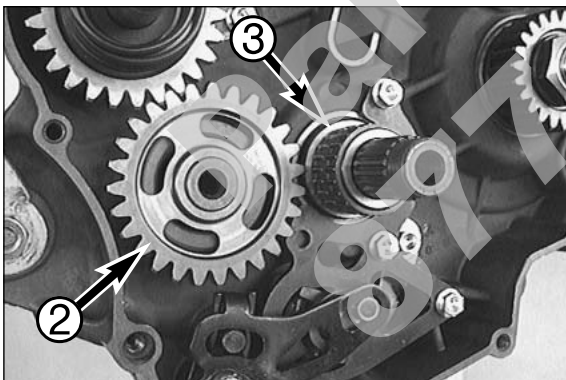

- Put the stop disc (17.2x26x1 mm) and the intermediate starter gear ❷ onto the countershaft.
- Oil the bearing of the outer clutch hub ❸ and put it onto the main shaft.



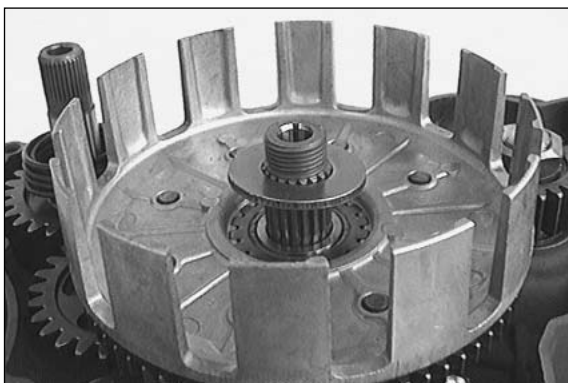

- Mount the outer clutch hub and the supporting disc (20x39.6x3 mm) on the main shaft.

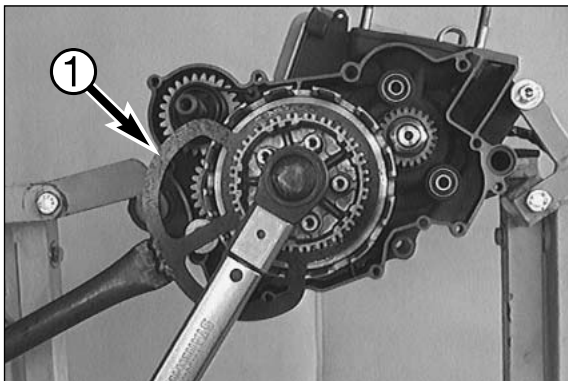

- Mount the inner clutch hub, a new lock washer and the hexagon nut on the main shaft.
- Mount the clutch holder ❶ and tighten the hexagon nut.
- Remove the clutch holder and secure the hexagon nut by bending the two brackets of the lock washer upwards.
- The bracket of the lock washer that meshes with the inner clutch hub must be carefully hammered down after tightening the hexagon nut to make sure that it rests properly against the inner clutch hub.

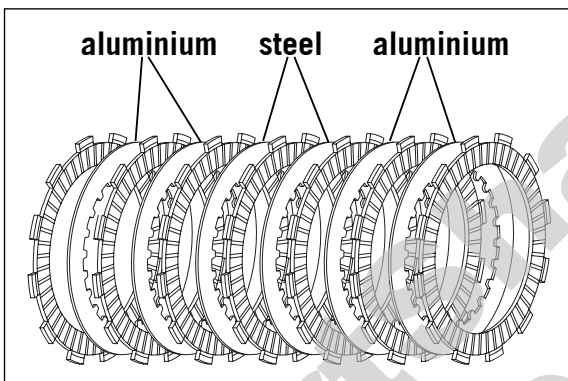

**Clutch discs and pressure cap**

- Oil the thrust bearing and insert it into the main shaft.
- Properly oil the lining discs before mounting them.

NOTE: These engines have 4 clutch discs of aluminium and 2 clutch discs of steel. These must be mounted in the following order:

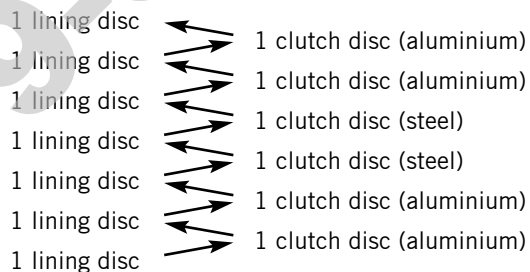

- One of the lining discs must be on top.
- Mount the pressure cap, then the clutch springs, the spring retainers and the collar bolts.
- Tighten the collar screws crosswise to torque, otherwise the thread in the driver will be damaged.

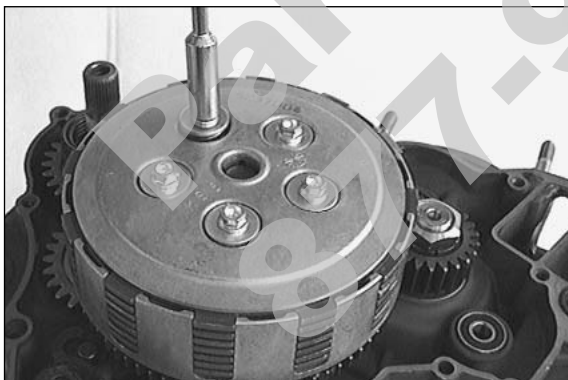

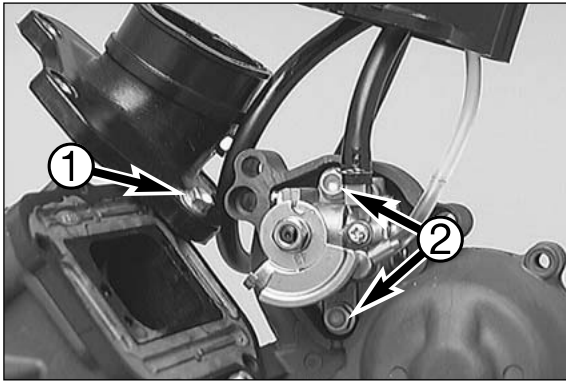

### Oil pump, reed valve housing and intake flange (separate lubrication)

- Insert the reed valve housing into the engine case and position the intake flange such that the bolt ① can be mounted. Mount the bolt, but only tighten it such that it is still possible to rotate the intake flange.
- Insert the oil pump with a new gasket into the engine case and fix it with the 2 bolts ②.

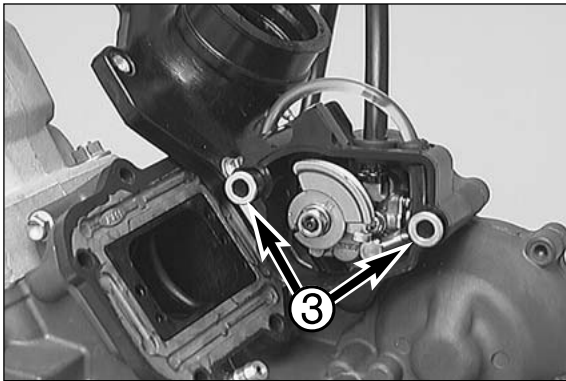

- Mount the oil pump housing. When mounting be careful not to kink the two hoses .
- Mount the 2 dowel bushings ③.

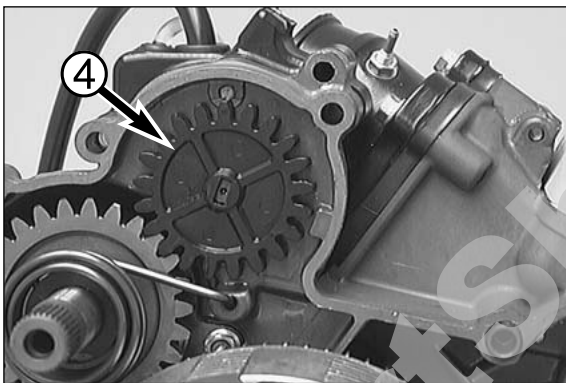

- Slide the oil-pump wheel ④ onto the oil pump.

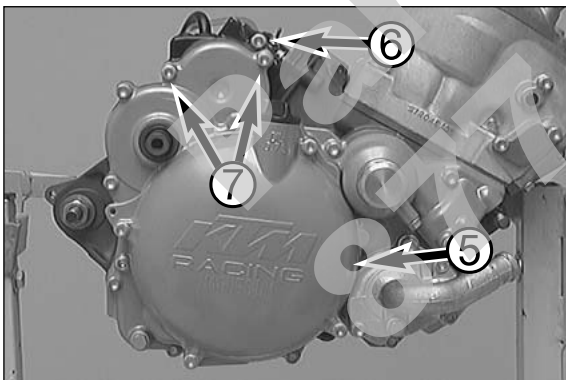

- Mount the clutch cover ⑤ and tighten the bolts including ⑥. To tighten the two bolts ⑦ it is necessary to hold the oil pump cover ③ in position.

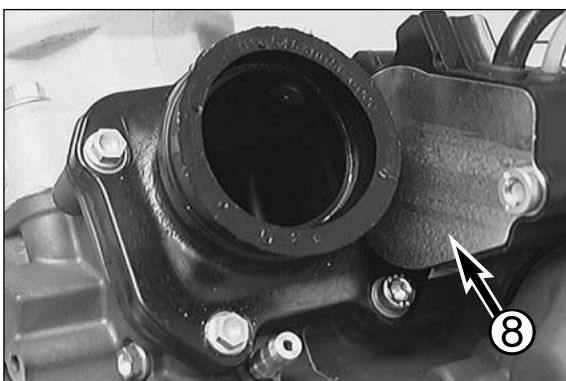

- Mount the remaining 4 bolts of the intake flange and tighten each of the 5 bolts.

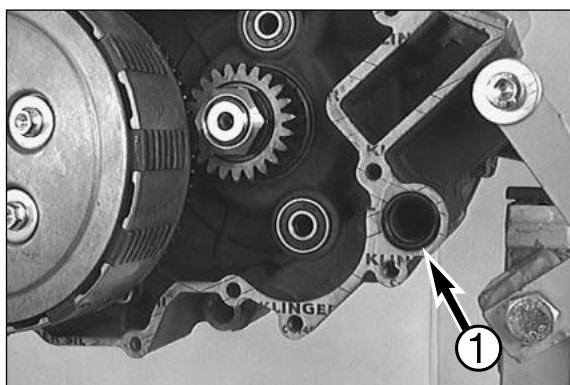

### Clutch cover

- Check if both dowels have been mounted in the engine housing.
- Grease the shaft seal ring of the kickstarter shaft and fix the clutch cover gasket with a small quantity of grease.
- Fix the O-ring ① in the housing with a small quantity of grease.
- Carefully mount the preassembled clutch cover and press it on. Slightly rotate the crankshaft so that the centrifugal timer and the water pump can mesh with the primary gear.
- Mount the collar bolts (bolt lengths indicated in the illustration on next page) and tighten with torque.
- Check all shafts for smooth operation.

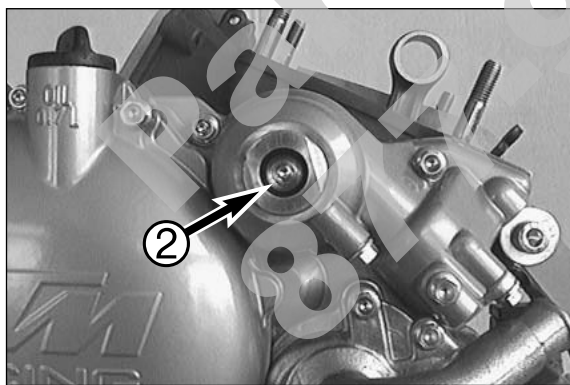
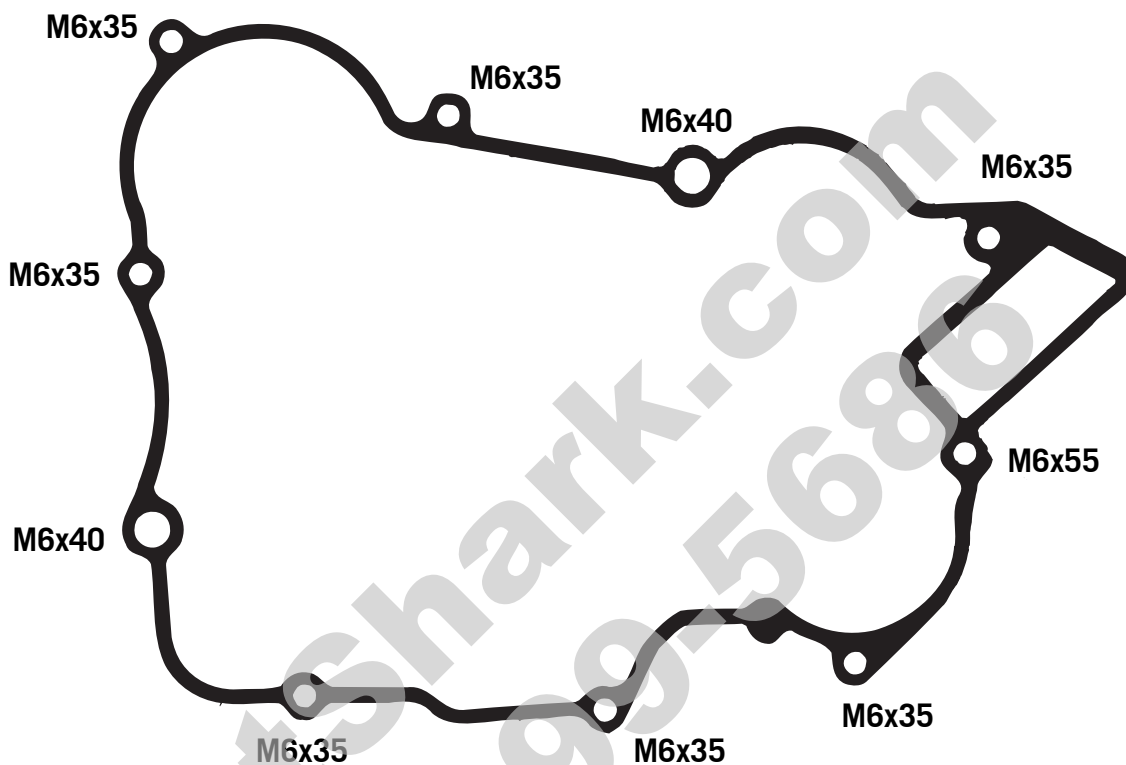

- Tighten the collar bolt ② of the centrifugal timer.



### Reed valve housing and intake flange

- Mount the reed valve housing and the intake flange and fix with 5 collar bolts and corrugated washers.
- Close the intake flange with a clean cloth or an appropriate plug.

NOTE: A reed valve plate is installed between the engine housing and reed valve housing in 200 cc engines from model 2006 onwards. Also mount this reed valve plate.

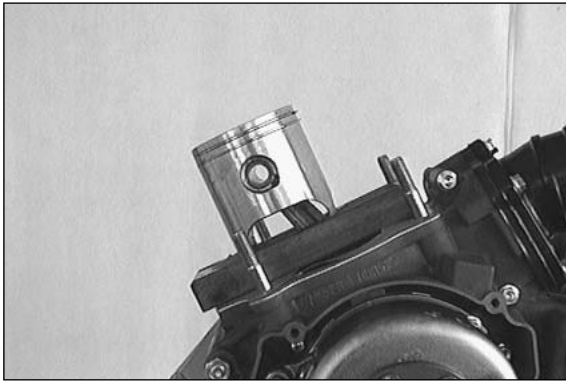

### Piston and cylinder

- Carefully oil the sliding points of all components before mounting.
- Insert the needle bearing into the conrod eye, mount the piston (the arrow on the piston head indicates the direction of the exhaust port).
- Mount the piston pin and the wire circlips with the open side facing downwards (see illustration).
- Mount the cylinder base gaskets (recommended gasket thickness: approx. 0.60 mm / 0.024 in).
- Place the piston on a self-made wooden mounting device and align the piston rings.

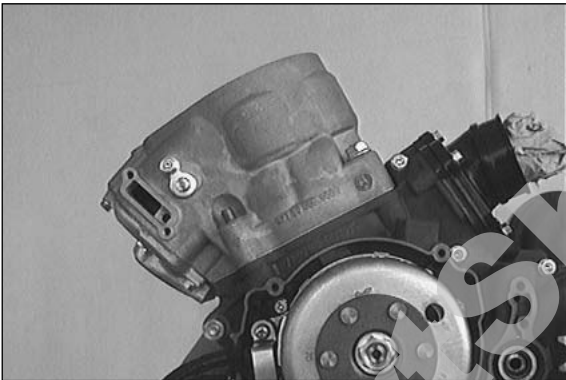
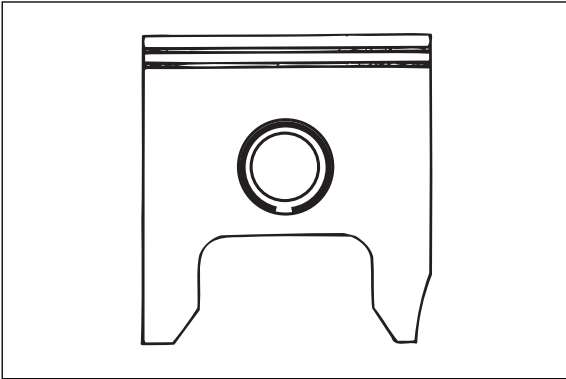

- Mount the preassembled cylinder, remove the mounting device and clamp the cylinder down with two collar nuts.

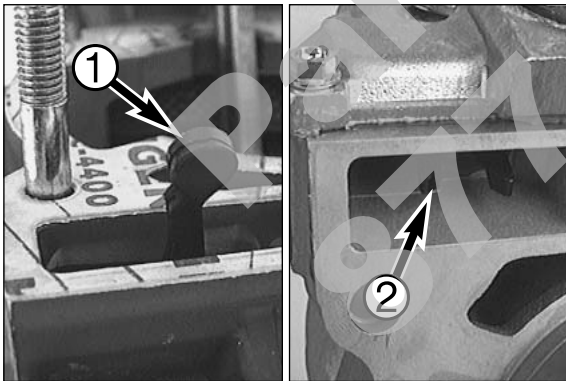

!

### CAUTION

!

WHEN MOUNTING THE CYLINDER MAKE SURE THAT THE ROCKER ARM **1** OF THE CENTRIFUGAL TIMER IS LOCATED IN THE CORRESPONDING RECESS **2** OF THE CONTROL SEGMENT IN THE CYLINDER. IF NECESSARY REMOVE THE SMALL CAP ON THE RIGHT SIDE OF THE CYLINDER AND CHECK.



### Adjusting dimension "X"

NOTE: Dimension "X" is the distance between the upper piston edge and the offset upper cylinder edge with the cylinder clamped down and the piston in position TDC.

Dimension "X" must be adjusted carefully by inserting cylinder base gaskets of different thicknesses.

!

### CAUTION

!

IF DIMENSION "X" IS TOO LARGE, THE COMPRESSION VALUE WILL DECREASE, THUS REDUCING THE OVERALL ENGINE OUTPUT. IF DIMENSION "X" IS TOO SMALL, THE ENGINE WILL "KNOCK" AND OVERHEAT.



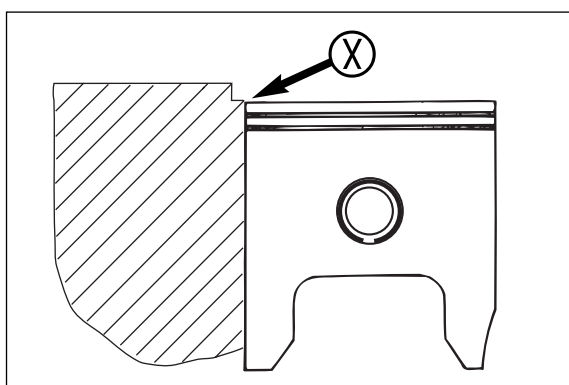

- Position the sliding gauge on the cylinder and turn the piston to TDC by turning the flywheel. Read the value indicated by the sliding gauge.

Dimension "X": see technical specification

- Adjust dimension "X" by adding or removing cylinder base gaskets.
- Mount the two remaining collar nuts at the cylinder base and tighten all 4 collar nuts with 30 Nm.

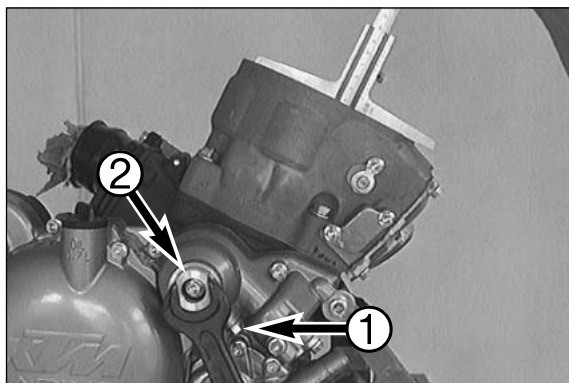

### Adjusting the control flap (dimension "Z")

NOTE: Dimension "Z" is the distance between the lower edge of the control flap and the upper edge of the cylinder, measured in the middle of the exhaust port.

- Loosen locking bolt **1** only 2 turns.
- Adjust the depth gauge to the indicated value and fix it in this position.
- Insert the depth gauge into the cylinder.
- Turn the bearing carrier **2** at the clutch cover so that the control flap rests against the depth gauge.

Dimension "Z": see technical specification

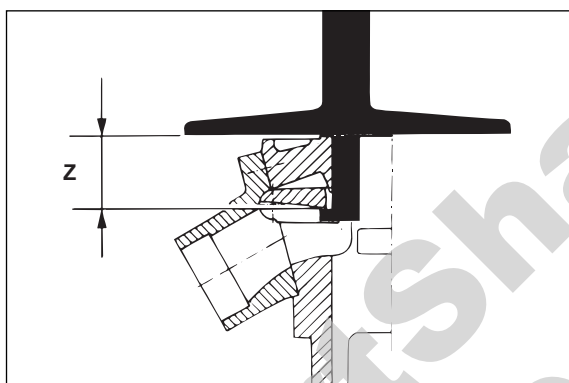

- Tighten the locking bolt **1** to prevent the bearing carrier from turning
- Mount the hexagon cap nut **3** of the centrifugal timer together with a new seal ring.

### ! CAUTION !

WHEN MOUNTING THE HEXAGON CAP NUT MAKE SURE THAT THE BEARING CARRIER OF THE CENTRIFUGAL TIMER IS NOT TURNED ANY MORE. OTHERWISE DIMENSION "Z" MUST BE ADJUSTED ONCE AGAIN.

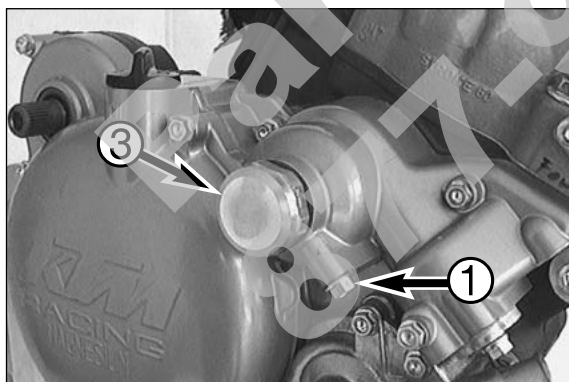

### Cylinder head

- Clean the sealing surfaces of the cylinder and the cylinder head.
- Insert a new O-ring into the corresponding groove of the cylinder and mount a new cylinder head gasket.

NOTE: An O-ring is used instead of the gasket on 125 cc engines from model 2002 onwards and on 200 cc engines from model 2003 onwards. Oil the O-ring and insert it in the recess in the cylinder.

- Mount the cylinder head with the water nozzle facing the exhaust side and slightly turn it back and forth to prevent crushing of the O-ring.
- Mount the collar bolts with new copper gaskets and tighten them crosswise, taking 3 turns to achieve the total tightening torque of 18 Nm.
- Initially, the bolts should only be tightened until the first slight resistance is felt.
- Insert and tighten the spark plug.

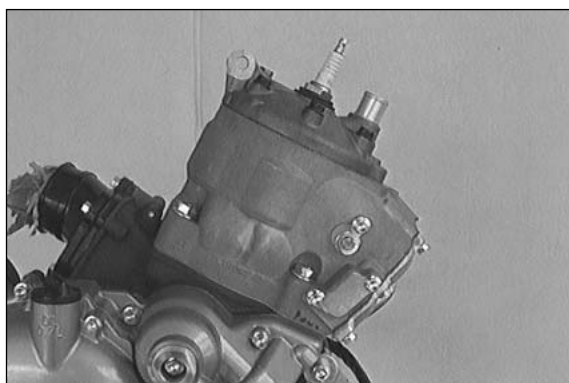

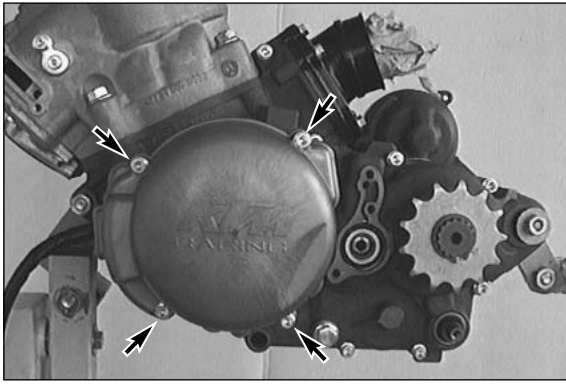

### Ignition cover

- Apply silicone to several points of the gasket to fix it in the ignition cover.
- Fix the ignition cover with 4 collar bolts.

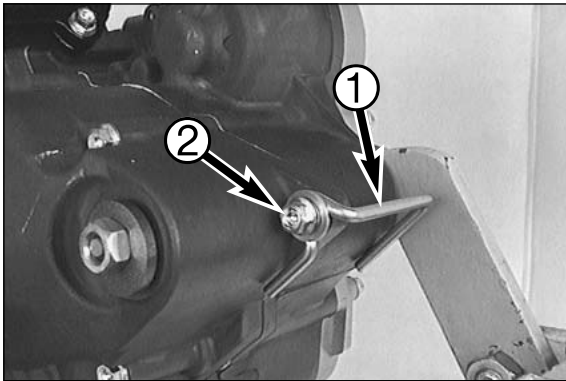

- Use the collar bolt ② to mount the wire bracket ① for the carburetor air hoses on the housing (up to model 2002).



### Measuring dimension "Y"

NOTE: The gasket of the driving cylinder of the clutch must be appropriately thick to ensure smooth clutch release. For this purpose measure dimension "Y". Dimension "Y" is the distance from the sealing surface of the clutch slave cylinder to the push rod.

- Swing the ignition side up.
- Oil the push rod and push it into the main shaft as far as it will go.
- Then use a sliding gauge to measure the distance between the bearing surface of the driving cylinder of the clutch and the push rod.
- Write down dimension "Y" and use an appropriate gasket (see table) when mounting the driving cylinder of the clutch.

With the old push rod in use (length = 179mm):

dimension "Y"	gasket thickness
2,5 - 2,8 mm	0,75 mm
2,8 - 3,0 mm	0,50 mm
3,0 - 3,3 mm	0,30 mm

With the new push rod in use (length = 178mm):

dimension "Y"	gasket thickness
3,0 - 3,8 mm	0,75 mm
3,8 - 4,0 mm	0,50 mm
4,0 - 4,3 mm	0,30 mm

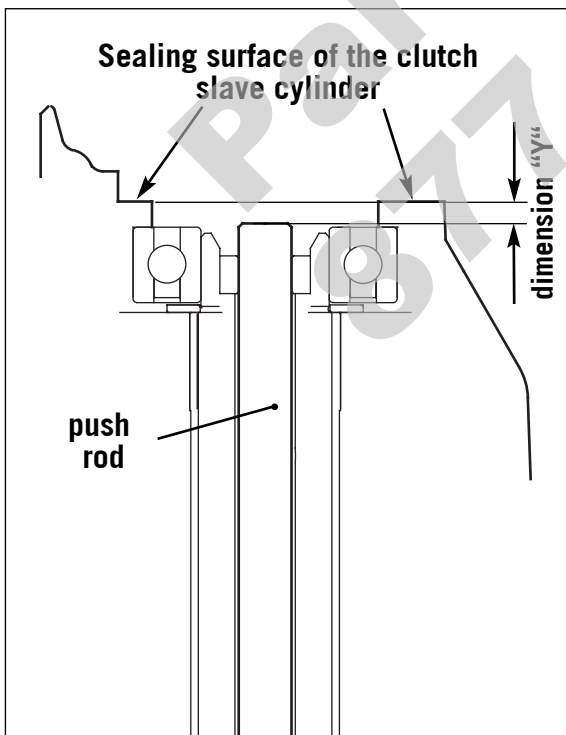

### ! CAUTION !

ALWAYS USE A NEW GASKET. DAMAGED GASKETS MAY IMPAIR THE EASY OPERABILITY OF THE HYDRAULIC CLUTCH.

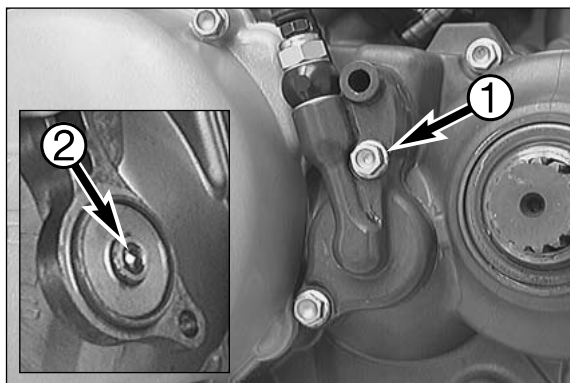

### Mounting the clutch slave cylinder

- Verify that the ball ② has been correctly mounted in the piston of the clutch slave cylinder.
- Put a new gasket in place and mount the clutch slave cylinder. Apply Loctite 243 onto the bolt's ① thread.

NOTE: To make sure the clutch works well, the correct thickness of the clutch slave cylinder gasket is to be measured - see dimension Y.

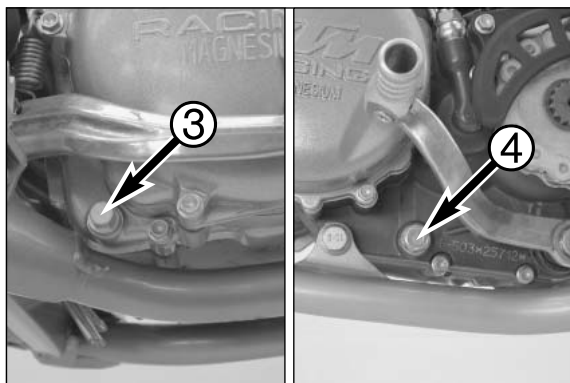

### Refilling the gear oil

- Clean the magnets of the oil drain plugs ③ and ④ and mount them together with the new gaskets.



- Remove the plug at the clutch cover and pour in 0.70 l oil (see specifications chapter 10).
- Mount the plug and check the engine for leaks.
- Mount the kickstart and shift lever.

**PartShark.com**  
**877-999-5686**

# ELECTRICAL

# 7

## INDEX

<b>CHECKING THE VOLTAGE REGULATOR-RECTIFIER (SHINDENGEN)</b> .....	<b>.7-2</b>
<b>CHECKING THE VOLTAGE REGULATOR (KOKUSAN)</b> .....	<b>.7-2</b>
<b>CHECKING THE CAPACITOR</b> .....	<b>.7-2</b>
<b>IGNITION COIL</b> .....	<b>.7-2</b>
<b>CDI UNIT</b> .....	<b>.7-3</b>

### MEASUREMENTS WITH PEAK VOLTAGE ADAPTER

#### UP TO MODEL 2004

<b>STATIC IGNITION VALUES 125-200 SX, MXC, EXC</b> .....	<b>.7-4</b>
<b>STATIC GENERATOR VALUES 125-200 EXC</b> .....	<b>.7-6</b>
<b>STATIC IGNITION VALUES / GENERATOR VALUES 125-200 MXC, EXC USA</b> .....	<b>.7-8</b>
<b>STATIC IGNITION VALUES 125 EXE, SUPERMOTO</b> .....	<b>.7-10</b>
<b>STATIC GENERATOR VALUES 125 EXE, SUPERMOTO</b> .....	<b>.7-12</b>

#### AS OF MODEL 2005

<b>STATIC IGNITION VALUES 125/200 SX, SXS, EXC, EXC SIX DAYS</b> .....	<b>.7-14</b>
<b>STATIC GENERATOR VALUES 125/200 EXC, EXC SIX DAYS</b> .....	<b>.7-16</b>
<b>STATIC IGNITION AND GENERATOR VALUES 125/200 EXC USA</b> .....	<b>.7-18</b>
<b>STATIC IGNITION AND GENERATOR VALUES 200 XC / XC-W</b> .....	<b>.7-18</b>



### Checking the voltage regulator-rectifier (Shindengen)

- Start the engine and switch on the low beam.
- Connect a voltmeter to the two terminals of the capacitor (red/white cable = positive, brown cable = negative).
- Accelerate the engine to a speed of 5000 r.p.m. and read off the voltage.

Nominal value: 14.0 - 15.0 V

In the case of a significant deviation from the nominal value:

- Check the capacitor
- Check the connector between the stator and the voltage regulator-rectifier and between the voltage regulator and the cable tree.
- Check the stator.
- Replace the voltage regulator-rectifier.

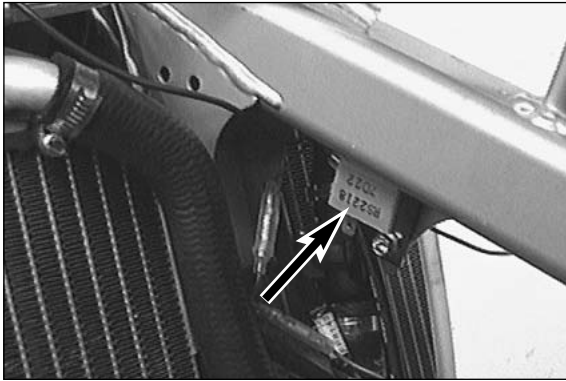

### Checking the voltage regulator (Kokusen)

A defect voltage regulator can cause different kinds of trouble:

- No voltage in the circuit  
In this case, the voltage regulator must be disconnected at idle speed. The voltage regulator is defect if the power consumers now work properly.  
If the power consumers are still not supplied with power, the switch, the wiring harness or the ignition system must be checked for defects.
- Excessive voltage in the circuit  
The bulbs burn out. In this case the voltage regulator must be replaced.

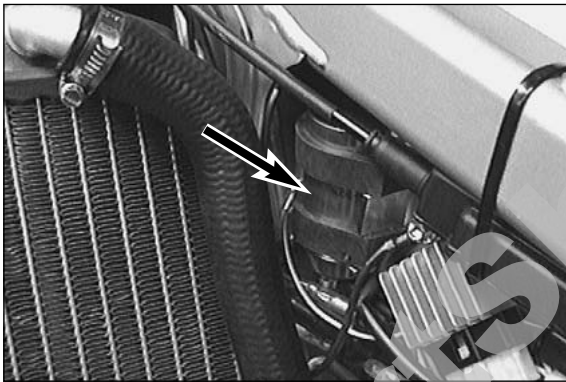

### Checking the capacitor

- Discharge the capacitor by bridging the two terminals with a screwdriver and remove.
- Connect the negative pole of a 12V battery with the negative terminal of the capacitor. The connection between the positive pole of the battery and the positive terminal of the capacitor (marked +) is made with a test lamp ③.
- When the power circuit is closed, the test lamp must begin to light up. As capacitor charging increases, the brightness of the test lamp must decrease.
- The test lamp must go out after 0,5 - 2 seconds (depending on the lamp capacity).
- If the test lamp does not go out or does not light up at all, the capacitor is faulty.

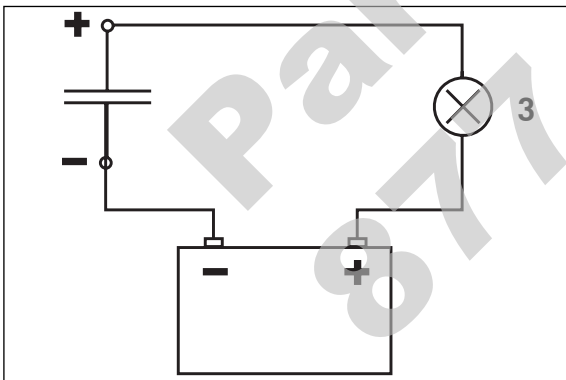

### ! CAUTION !

DISCHARGE THE CAPACITOR BEFORE AND AFTER EACH TEST.

WHEN INSTALLING THE CAPACITOR, MAKE SURE THAT THE TERMINALS ARE CONNECTED IN ACCORDANCE WITH THEIR MARKINGS (CONNECT RED/WHITE CABLE TO + TERMINAL).

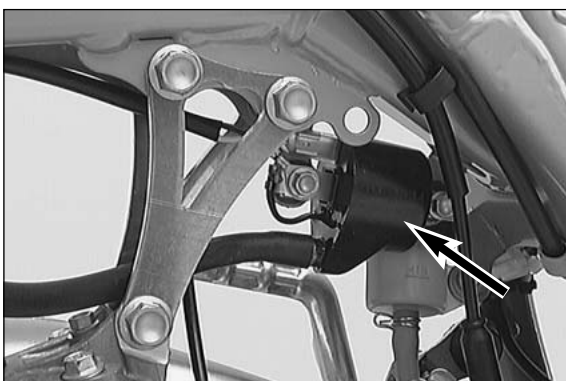

### Ignition coil

- Disconnect all cables and remove the spark plug connector.
- Use an ohmmeter to measure the following values.

NOTE: The indicated setpoint values correspond to a temperature of 20° C.

Replace the ignition coil if the measured values deviate significantly from the setpoint values.

Primary coil	Ignition coil – ground	0,26 - 0,35 Ω
Secondary coil	Ignition coil – ignition cable without spark plug connector	5 - 7,6 kΩ

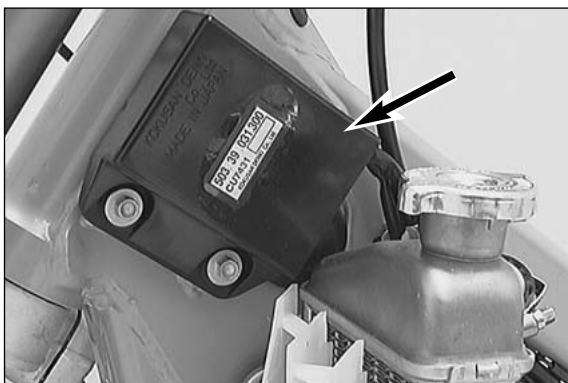
**CDI unit**

Check the cables, plug and socket connections of the CDI unit.  
The CDI unit function can only be checked on an ignition test bench.

---

**! CAUTION !**

---

NEVER USE A COMMERCIAL MEASURING DEVICE TO CHECK THE CDI UNIT.  
COMMERCIAL MEASURING DEVICES CAN DESTROY HIGHLY SENSITIVE ELECTRONIC COMPONENTS.



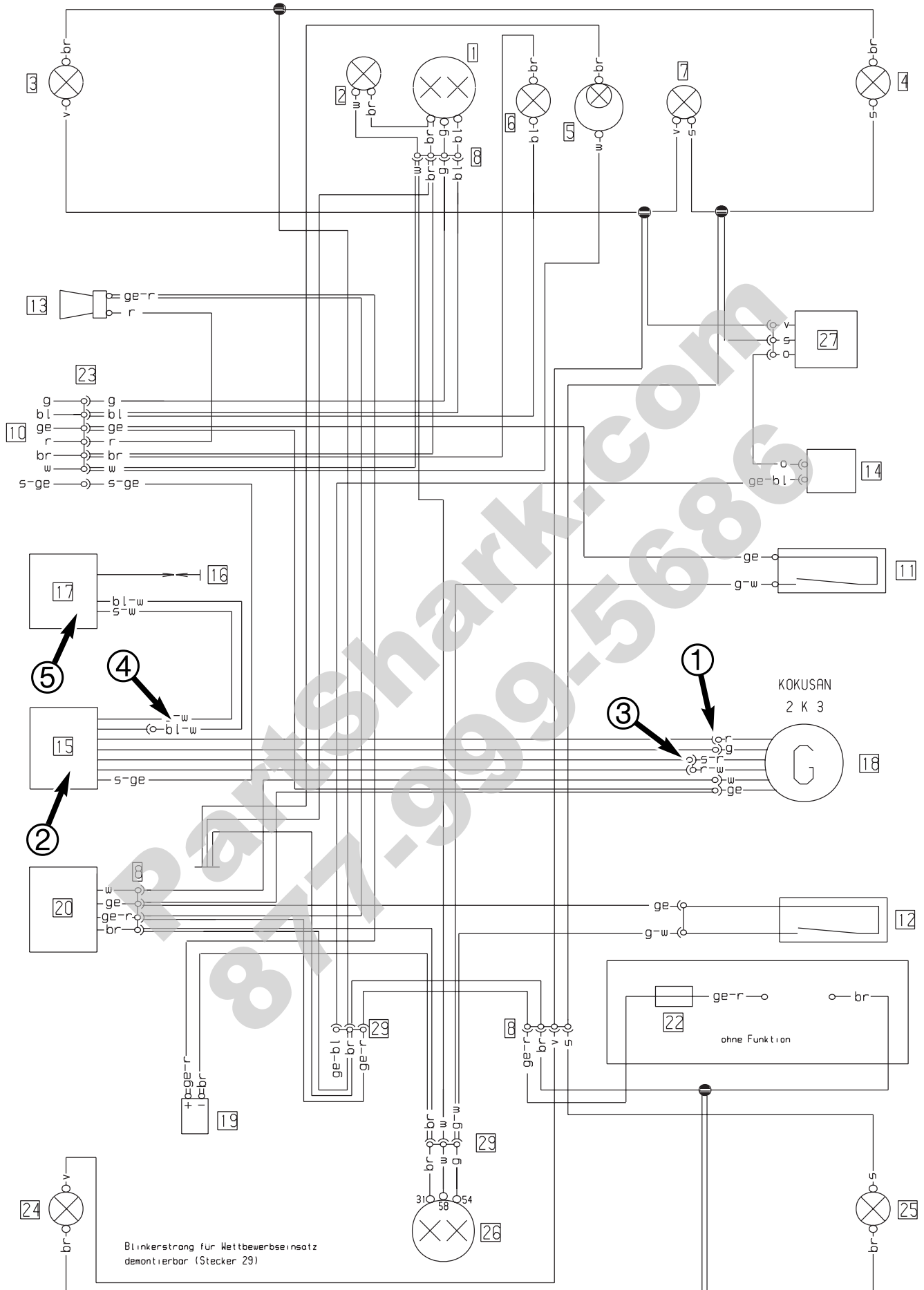



## STATIC IGNITION VALUES 125-200 SX, MXC, EXC (KOKUSAN 2K-1, 2K-3) → 2004

### Measuring conditions:

- cold engine
- seat and tank removed
- all connectors and the ground connection in a non-corroding condition, connectors tightly connected
- spark plug screwed out and spark plug connector attached to ground
- light switch turned off
- the gap between the rotor and pulse generator must be set to 0.75 mm
- kick the kick starter forcefully at least 5 times for each measurement

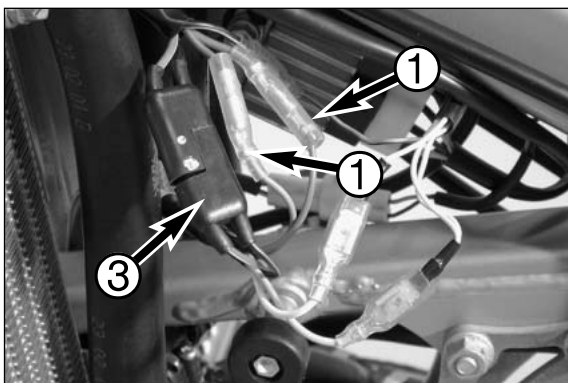

Check the **pulse generator** for an output signal – two-pin connector **1** with green and red cable colors (also see circuit diagram on opposite page):

- Apply the red measuring lead of the peak voltage adapter to the green cable and the black measuring lead to the red cable, disconnect both connectors **1** to disconnect the CDI unit **2**

Multimeter display: 6 volts +/- 1 volt

- Same measurement with CDI unit connected

Multimeter display: 3 volts +/- 1 volt

Check the **generator charging coil** for ignition capacitor charge for output voltage – two-pin connector **3** with black/red and red/white cable colors (also see circuit diagram on opposite page):

- Apply the red measuring lead of the peak voltage adapter to the black/red cable and the black measuring lead to the red/white cable, disconnect connector **3** to disconnect the CDI unit **2**

Multimeter display: 35 volts +/- 5 volts

- Same measurement with connectors CDI unit connected

Multimeter display: 200 volts +/- 10 volts

Check the **primary voltage output** **4** for ignition coil control (also see circuit diagram on opposite page) for output voltage (blue/white cable color):

- Apply the red measuring lead **6** of the peak voltage adapter to the black/white cable (ground) and the black measuring lead **5** to the blue/white cable, CDI unit **2** and ignition coil **5** connected

Multimeter display: 200 volts +/- 10 volts

NOTE: The ignition coil does not need to be removed to take a measurement.

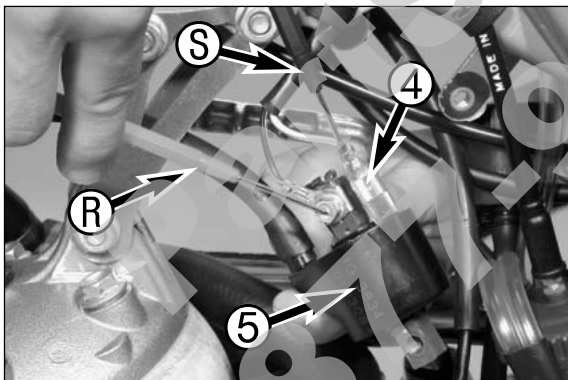

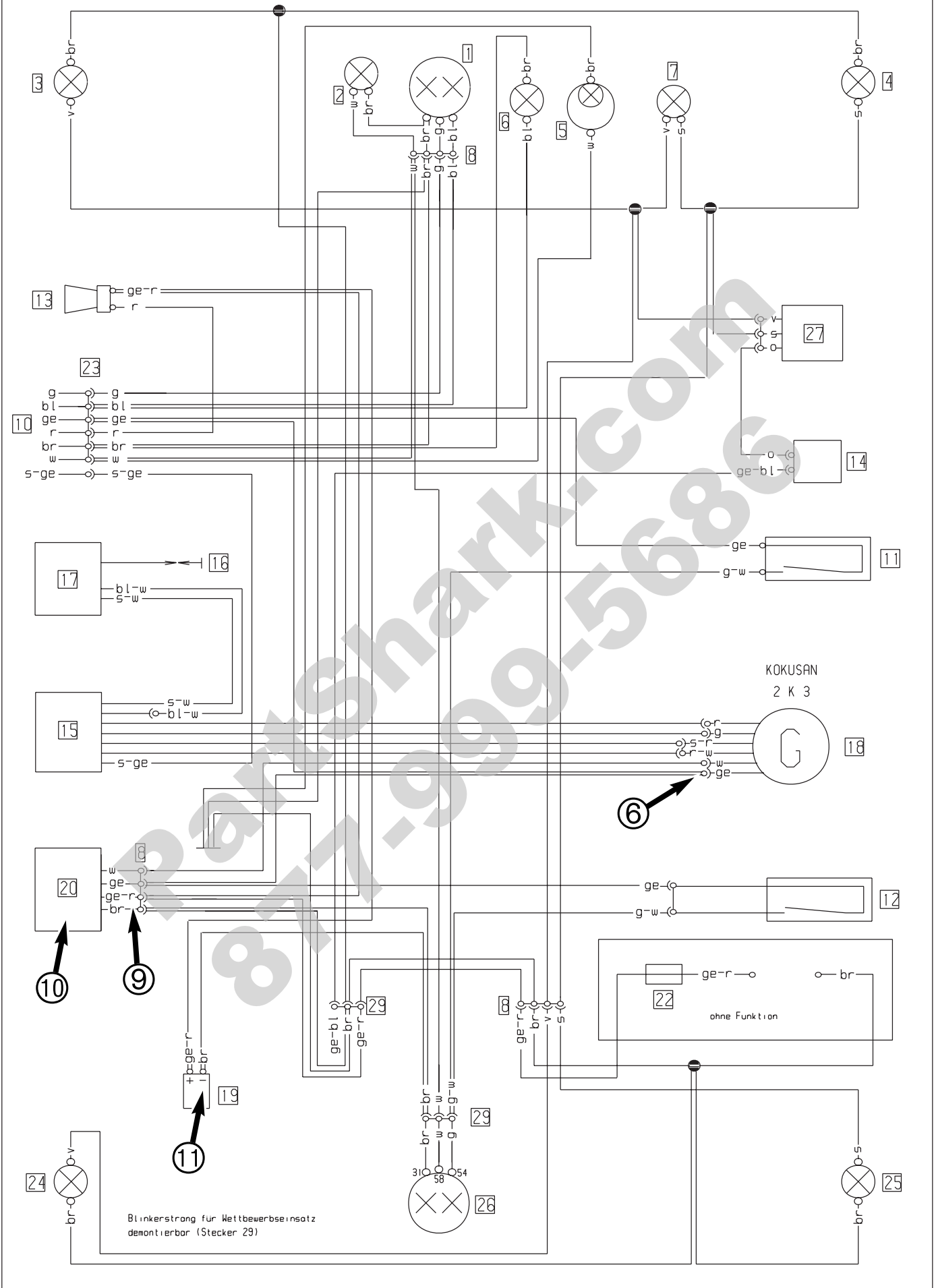

## STATIC GENERATOR VALUES 125-200 EXC (KOKUSAN 2K-3) → 2004

### Measuring conditions:

- cold engine
- seat and tank removed
- all connectors and the ground connection in a non-corroding condition, connectors tightly connected
- light switch turned off
- kick the kick starter forcefully at least 5 times for each measurement

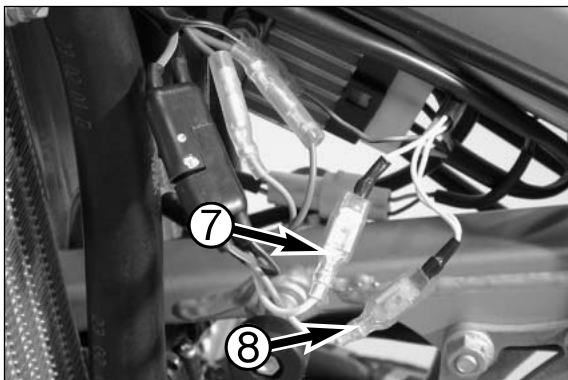

Check the generator output ⑥ (also see circuit diagram on opposite page) for voltage between the following cable colors:

- between yellow and brown (ground), connector ⑦ disconnected

Multimeter display: 19 volts +/- 2 volts

- between white and brown (ground), connector ⑧ disconnected

Multimeter display: 24 volts +/- 2 volts

- Repeat both measurements with connectors ⑦ and ⑧ connected. The measured values should be the same.

NOTE: The black measuring lead of the peak voltage adapter must be applied to the ground.

Check **regulator rectifier output voltage** ⑨ (also see circuit diagram on opposite page) cable colors yellow/red, regulator rectifier ⑩ connected, capacitor ⑪ disconnected:

- between yellow/red and brown (ground)

Multimeter display: 14 volts +/- 1 volt

NOTE: The black measuring lead ⑤ of the peak voltage adapter must be applied to the ground.

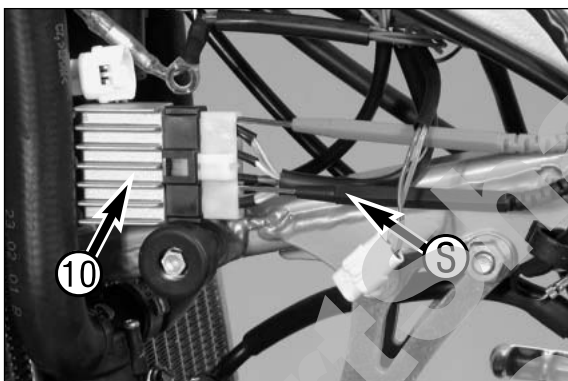



SERVICE

Modell 125/200/250 EXC 2001

Kabelstrangnummer  
 vorne 503 11 075 000  
 hinten 503 11 076 000

Land USA

Datum, Name  
 22 06 98 KE

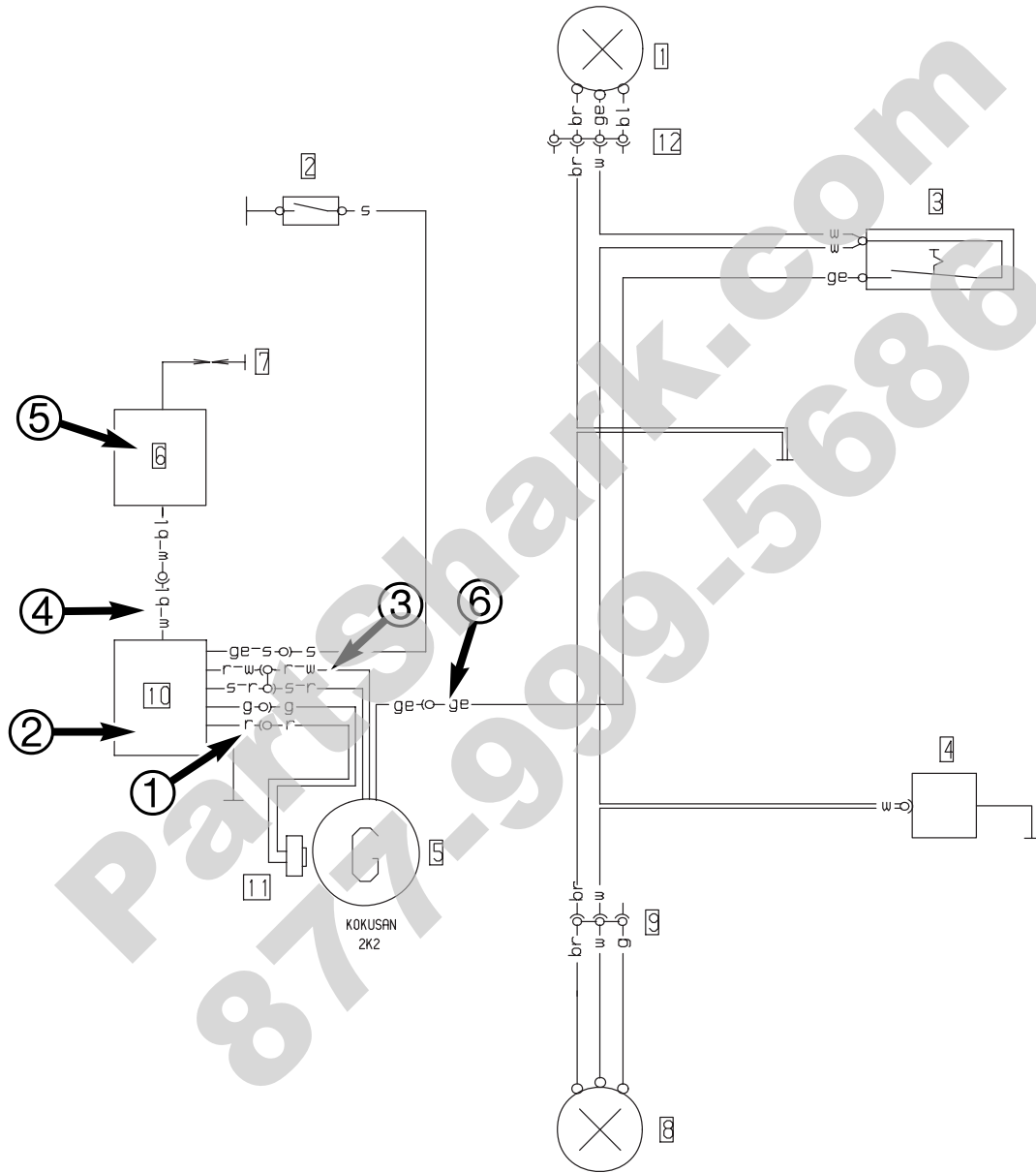

## STATIC IGNITION AND GENERATOR VALUES 125-200 MXC, EXC USA (KOKUSAN 2K-2) → 2004

### Measuring conditions:

- cold engine
- seat and tank removed
- all connectors and the ground connection in a non-corroding condition, connectors tightly connected
- spark plug screwed out and spark plug connector attached to ground
- light switch turned off
- the gap between the rotor and pulse generator must be set to 0.75 mm
- kick the kick starter forcefully at least 5 times for each measurement

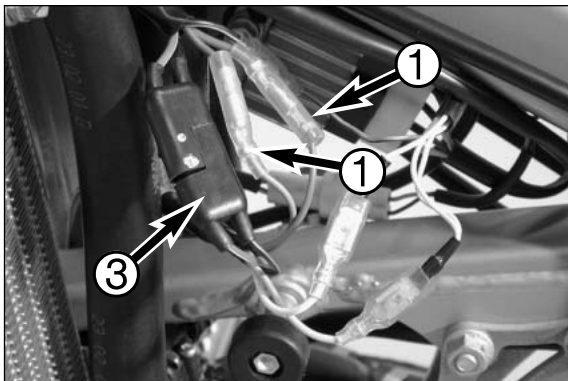

Check the **pulse generator** for an output signal – two one-pin connectors **1** with green and red cable colors (also see circuit diagram on opposite page):

- Apply the red measuring lead of the peak voltage adapter to the green cable and the black measuring lead to the red cable, disconnect both connectors **1** to disconnect the CDI unit **2**

Multimeter display: 3.5 volts +/- 1 volt

- Same measurement with CDI unit connected

Multimeter display: 2 volts +/- 0.5 volt

Check the **generator charging coil** for ignition capacitor charge for output voltage – two-pin connector **3** with black/red and red/white cable colors (also see circuit diagram on opposite page)

- apply the red measuring lead of the peak voltage adapter to the black/red cable and the black measuring lead to the red/white cable, disconnect connector **3** to disconnect the CDI unit **2**

Multimeter display: 45 volts +/- 5 volts

- Same measurement with connectors CDI unit connected

Multimeter display: 220 volts +/- 10 volts

Check the **primary voltage output** **4** for ignition coil control (also see circuit diagram on opposite page) for output voltage (blue/white cable color):

- apply the red measuring lead **6** of the peak voltage adapter to the black/white cable (ground) and the black measuring lead **5** to the blue/white cable, CDI unit **2** and ignition coil **5** connected

Multimeter display: 210 volts +/- 10 volts

NOTE: The ignition coil does not need to be removed to take a measurement.

Check the **generator output** **6** for the lighting system (also see circuit diagram on opposite page) for voltage:

- between yellow and brown (ground), connector disconnected

Multimeter display: 10.5 volts +/- 1 volt

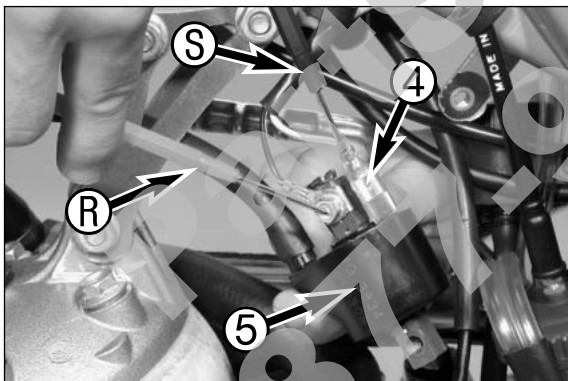

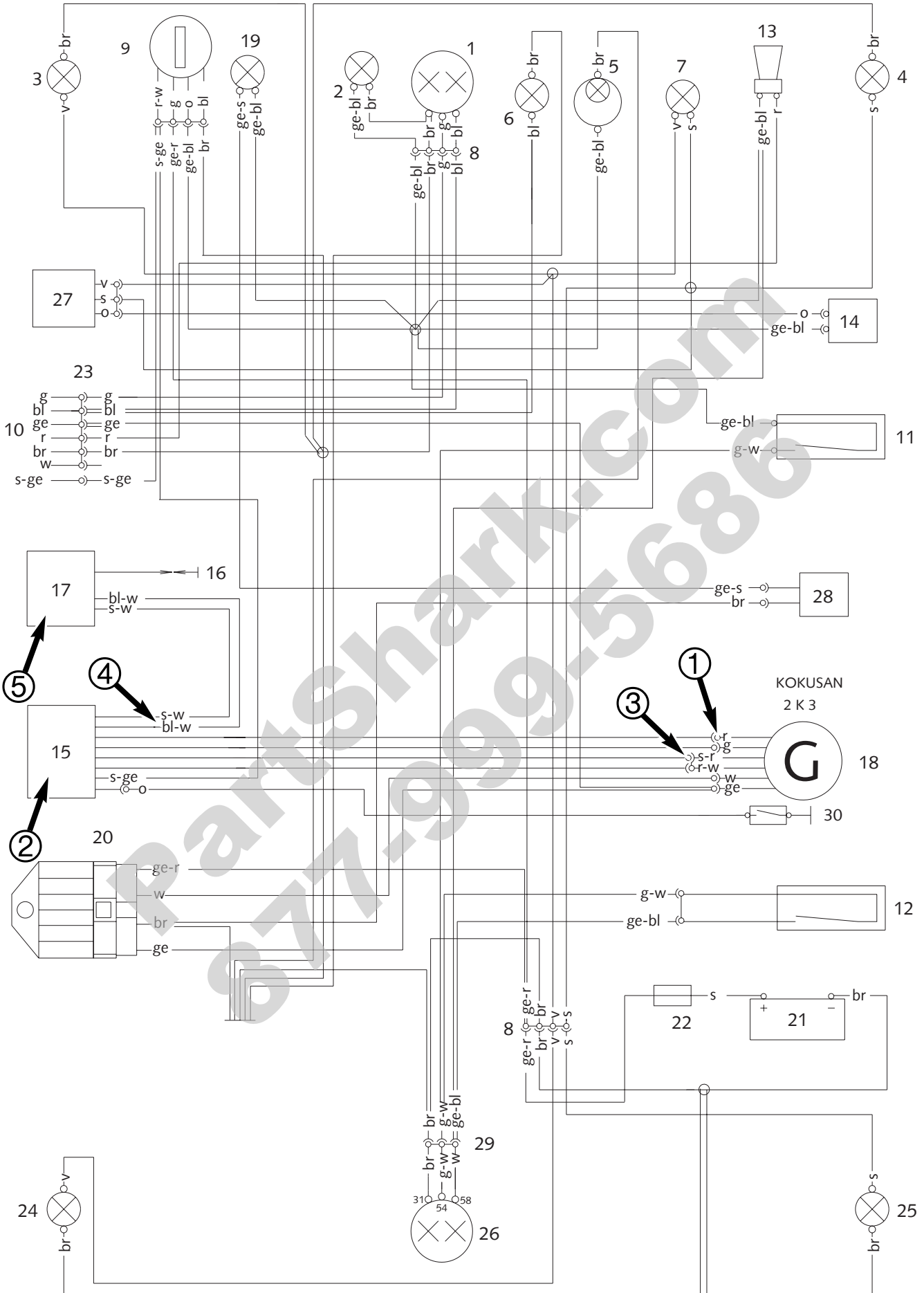

## STATIC IGNITION VALUES 125 EXE / 125 SUPERMOTO (KOKUSAN 2K-3) → 2004

### Measuring conditions:

- cold engine
- seat and tank removed
- all connectors and the ground connection in a non-corroding condition, connectors tightly connected
- spark plug screwed out and spark plug connector attached to ground
- battery loaded, ignition switch to position 1 (light turned off)
- the gap between the rotor and pulse generator must be set to 0.75 mm
- kick the kick starter forcefully at least 5 times for each measurement

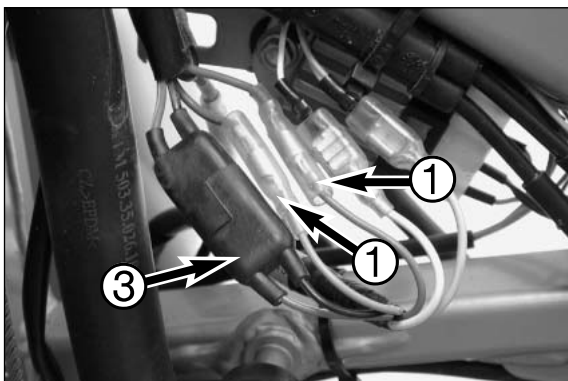

Check the **pulse generator** for an output signal – two one-pin connectors **1** with green and red cable colors (also see circuit diagram on opposite page):

- Apply the red measuring lead of the peak voltage adapter to the green cable and the black measuring lead to the red cable, disconnect both connectors **1** to disconnect the CDI unit **2**

Multimeter display: 6 volts +/- 1 volt

- Same measurement with CDI unit connected

Multimeter display: 3 volts +/- 1 volt

Check the **generator charging coil** for the ignition capacitor charge for output voltage – two-pin connector **3** with black/red and red/white cable colors (also see circuit diagram on opposite page):

- Apply the red measuring lead of the peak voltage adapter to the black/red cable and the black measuring lead to the red/white cable, disconnect connector **3** to disconnect the CDI unit **2**

Multimeter display: 35 volts +/- 5 volts

- Same measurement with connectors CDI unit connected

Multimeter display: 200 volts +/- 10 volts

Check the **primary voltage output** **4** for ignition coil control (also see circuit diagram on opposite page) for output voltage (blue/white cable color):

- Apply the red measuring lead **4** of the peak voltage adapter to black/white cable (ground) and the black measuring lead **5** to the blue/white cable, CDI unit **2** and ignition coil **5** connected

Multimeter display: 200 volts +/- 10 volts

NOTE: The ignition coil does not need to be removed to take a measurement.

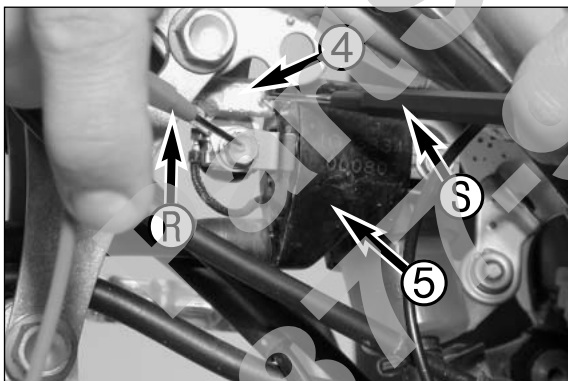

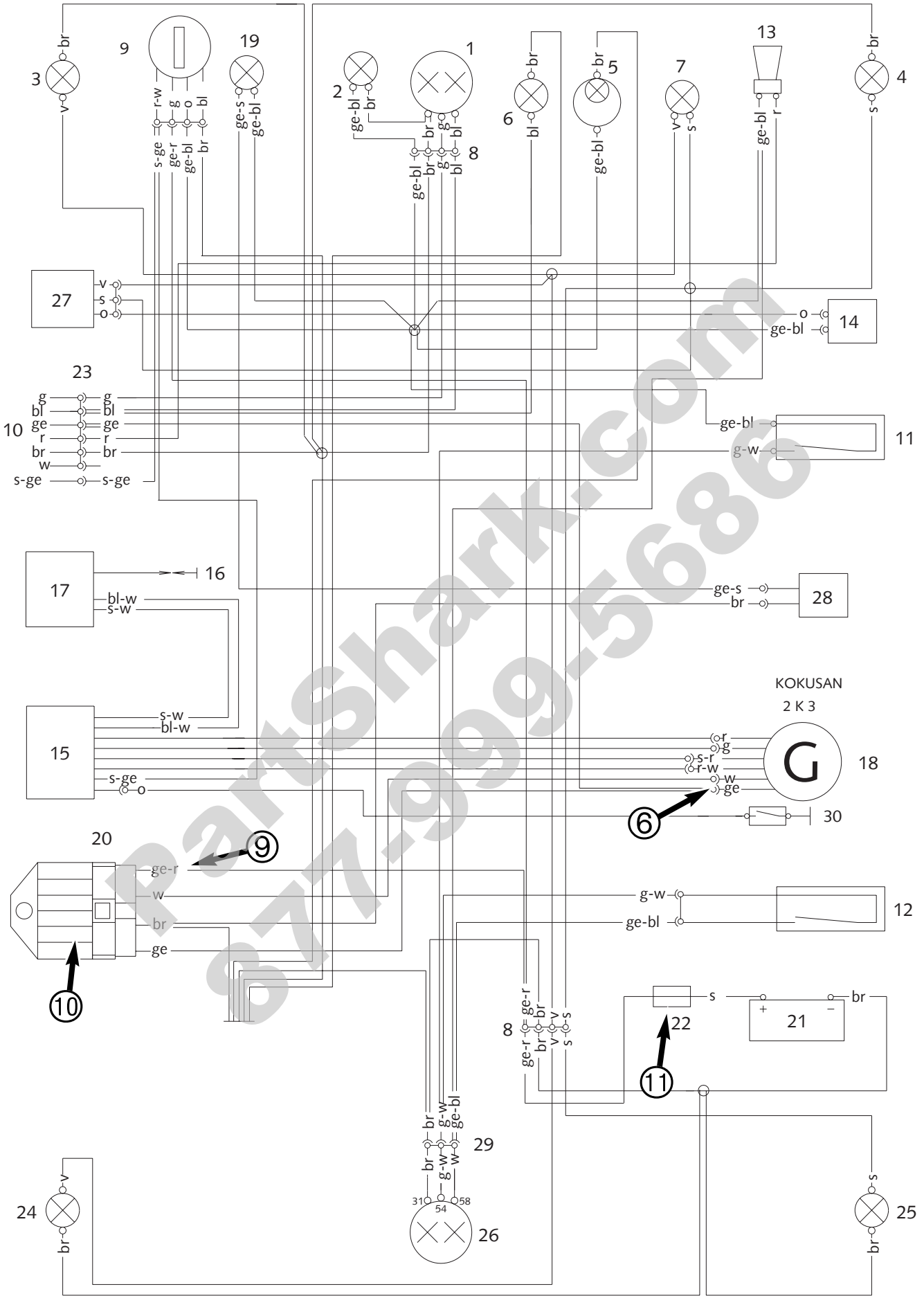



## STATIC GENERATOR VALUES 125 EXE / 125 SUPERMOTO (KOKUSAN 2K-3) → 2004

### Measuring conditions:

- cold engine
- seat and tank removed
- all connectors and the ground connection in a non-corroding condition, connectors tightly connected
- battery loaded, ignition switch to position 1 (light turned off)
- kick the kick starter forcefully at least 5 times for each measurement

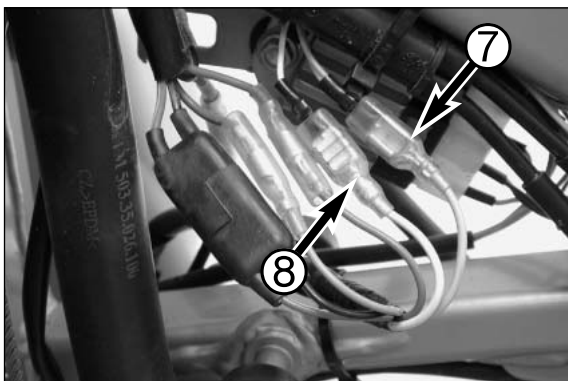

Check the **generator output** ⑥ (also see circuit diagram on opposite page) for voltage between the following cable colors:

- between yellow and brown (ground), connector ⑦ disconnected

Multimeter display: 19 volts +/- 2 volts

- between white and brown (ground), connector ⑧ disconnected

Multimeter display: 24 volts +/- 2 volts

- Repeat both measurements with connectors ⑦ and ⑧ connected. The measured values should be the same.

NOTE: The black measuring lead of the peak voltage adapter must be applied to the ground.

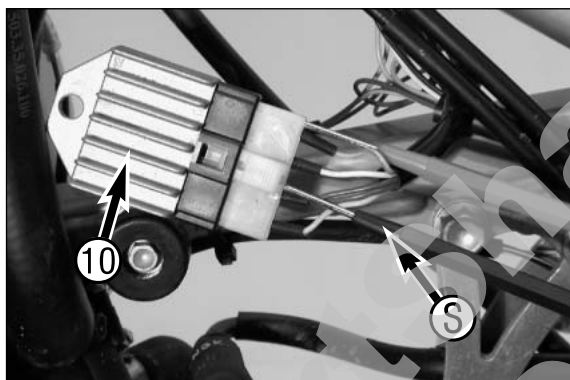

Check **regulator rectifier output voltage** ⑨ (also see circuit diagram on opposite page) cable colors yellow/red, regulator rectifier ⑩ connected, fuse ⑪ disconnected, ignition switched off:

- between yellow/red and brown (ground)

Multimeter display: 14 volts +/- 1 volt

NOTE: The black measuring lead ⑤ of the peak voltage adapter must be applied to the brown cable (ground).

## STATIC IGNITION VALUES 125/144/200 SX, SXS, EXC, EXC SIX DAYS (KOKUSAN 2K-1, 2K-3) 2005 →

### Measuring conditions:

- cold engine
- seat and tank removed
- all connectors and the ground connection in a non-corroding condition, connectors tightly connected
- spark plug screwed out and spark plug connector attached to ground
- light switch turned off
- the gap between the rotor and pulse generator must be set to 0.75 mm
- kick the kick starter forcefully at least 5 times for each measurement

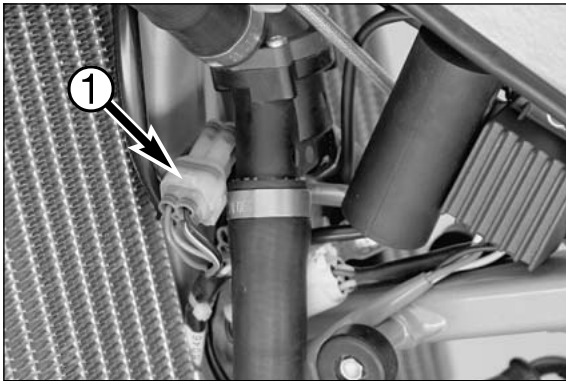

Check the **pulse generator** for output signal - 4-pole plug ❶ with cable colors green, red, black/red and red/white (also see wiring diagram on opposite page):

- Apply the red measuring tip of the peak voltage adapter to the green cable and the black measuring tip to the red cable, disconnect plug ❶ to disconnect the CDI unit ❷

Multimeter display: 6 volts  $\pm$  1 volt

- Same measurement with CDI unit connected

Multimeter display: 3 volts  $\pm$  1 volt

Check the **generator charging coil** for the ignition capacitor charge for output voltage 4-pole plug ❶ with green, red, black/red and red/white cable colors (also see circuit diagram on opposite page).

- Apply the red measuring lead of the peak voltage adapter to the black/red cable and the black measuring lead to the red/white cable, disconnect connector ❶ to disconnect the CDI unit ❷

Multimeter display: 35 volts  $\pm$  5 volts

- Same measurement with connectors CDI unit connected

Multimeter display: 200 volts  $\pm$  10 volts

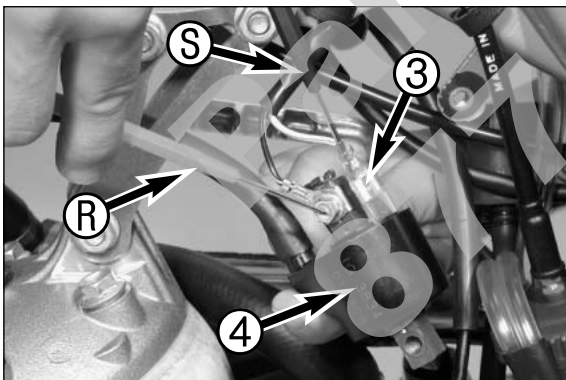

Check the **primary voltage output** ❸ for ignition coil control (also see circuit diagram on opposite page) for output voltage (white/blue cable color):

- Apply the red measuring lead ❶ of the peak voltage adapter to the black/white cable (ground) and the black measuring lead ❷ to the white/blue cable, CDI unit ❷ and ignition coil ❹ connected

Multimeter display: 200 volts  $\pm$  10 volts

NOTE: The ignition coil does not need to be removed to take a measurement.



EXC 125-200 2005

wiring diagramm

main harness

548.11.075.250

20.02.2004

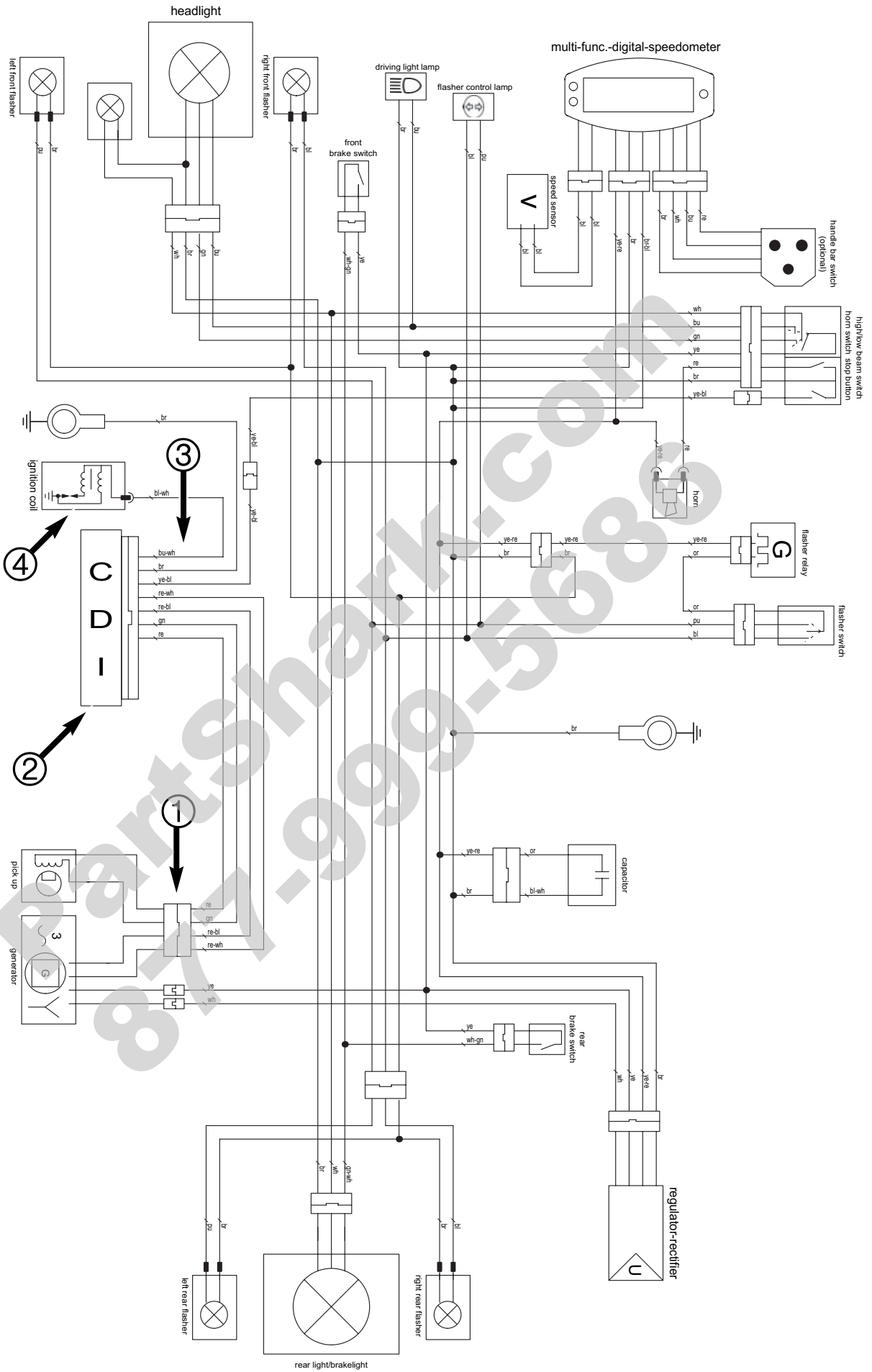

## STATIC GENERATOR VALUES 125/200 EXC, EXC SIX DAYS (KOKUSAN 2K-3) 2005 →

### Measuring conditions:

- cold engine
- seat and tank removed
- all connectors and the ground connection in a non-corroding condition, connectors tightly connected
- light switch turned off
- kick the kick starter forcefully at least 5 times for each measurement

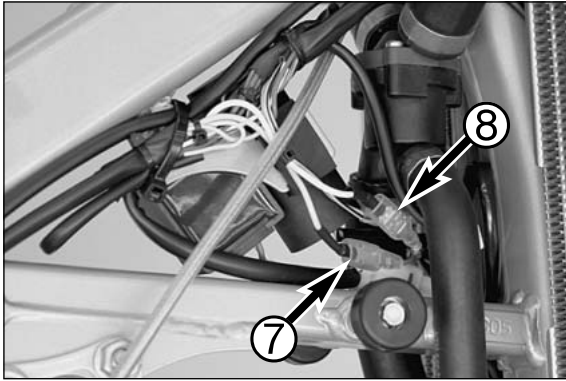

Check the **generator output** ⑥ (also see circuit diagram on opposite page) for voltage between the following cable colors:

- between yellow and brown (ground), connector ⑦ disconnected

Multimeter display      19 volts  $\pm$ 2 volts

- between white and brown (ground), connector ⑧ disconnected

Multimeter display      24 volts  $\pm$ 2 volts

- Repeat both measurements with connectors ⑦ and ⑧ connected. The measured values should be the same.

NOTE: The black measuring lead of the peak voltage adapter must be applied to the ground.



Check **regulator rectifier** output voltage ⑨ (also see circuit diagram on opposite page) cable colors yellow/red, regulator rectifier ⑩ connected, capacitor ⑪ disconnected:

- between yellow/red and brown (ground)

Multimeter display: 14 volts  $\pm$  1 volt

### NOTE:

- The black measuring lead of the peak voltage adapter must be applied to the ground.



EXC 125-200 2005

wiring diagramm

main harness

548.11.075.250

20.02.2004

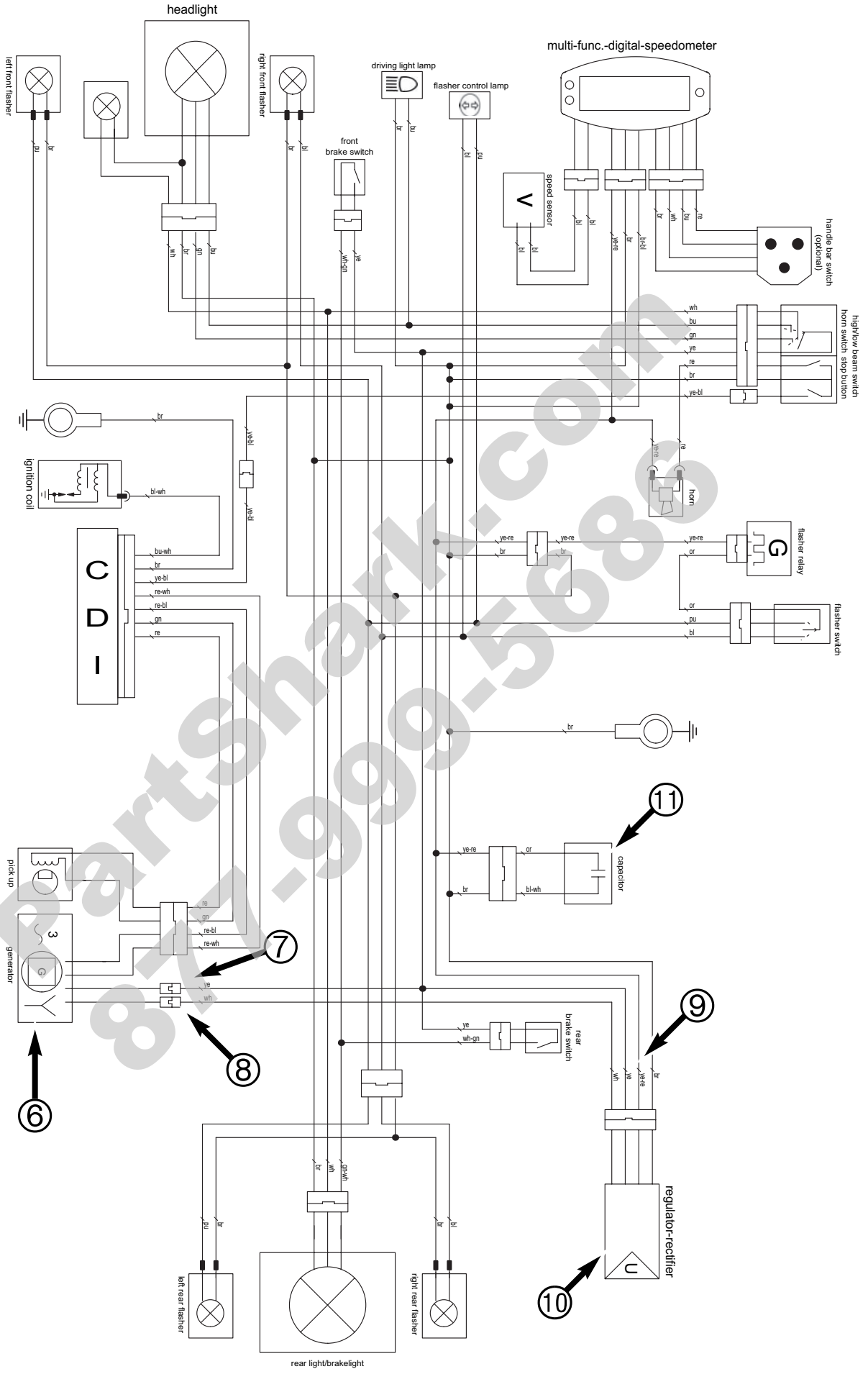

Art.-Nr. 3.206.062-E

Repair manual KTM 125 / 144 / 150 / 200

## STATIC IGNITION AND GENERATOR VALUES 125/200 EXC USA (KOKUSAN 2K-2) 2005 STATIC IGNITION AND GENERATOR VALUES 200 XC / XC-W (KOKUSAN 2K-2) 2006

### Measuring conditions:

- cold engine
- seat and tank removed
- all connectors and the ground connection in a non-corroding condition, connectors tightly connected
- spark plug screwed out and spark plug connector attached to ground
- light switch turned off
- the gap between the rotor and pulse generator must be set to 0.75 mm
- kick the kick starter forcefully at least 5 times for each measurement

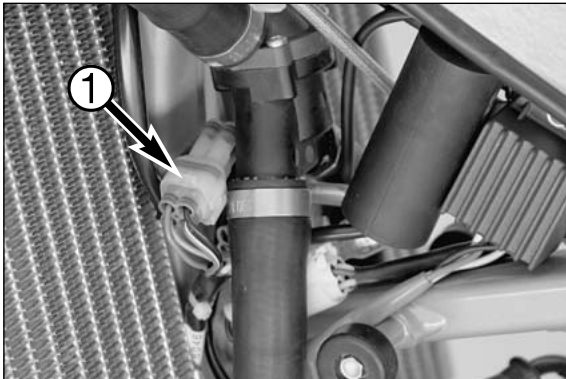

Check the **pulse generator** for output signal - 4-pole plug **1** with cable colors green, red, black/red and red/white (also see wiring diagram on opposite page):

- Apply the red measuring tip of the peak voltage adapter to the green cable and the black measuring tip to the red cable, disconnect plug **1** to disconnect the CDI unit **2**

Multimeter display: 3.5 volts  $\pm$  1 volt

- Same measurement with CDI unit connected

Multimeter display: 2 volts  $\pm$  0.5 volt

Check the **generator charging coil** for ignition capacitor charge for output voltage - two-pin connector **3** with green, red, black/red and red/white cable colors (also see circuit diagram on opposite page)

- apply the red measuring lead of the peak voltage adapter to the black/red cable and the black measuring lead to the red/white cable, disconnect connector **1** to disconnect the CDI unit **2**

Multimeter display: 45 volts  $\pm$  5 volts

- Same measurement with connectors CDI unit connected

Multimeter display: 220 volts  $\pm$  10 volts

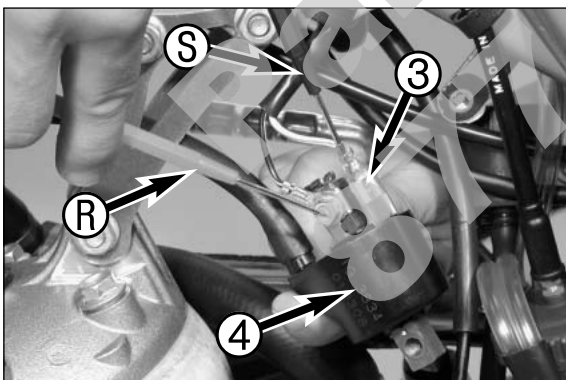

Check the **primary voltage** output **3** for ignition coil control (also see circuit diagram on opposite page) for output voltage (white/blue cable color):

- apply the red measuring lead **6** of the peak voltage adapter to the black/white cable (ground) and the black measuring lead **5** to the white/blue cable, CDI unit **2** and ignition coil **4** connected

Multimeter display: 210 volts  $\pm$  10 volts

NOTE: The ignition coil does not need to be removed to take a measurement.

Check the **generator output** **5** (not available for 200 XC) for the lighting system (also see circuit diagram on opposite page) for voltage:

- between yellow and brown (ground), connector disconnected

Multimeter display: 10.5 volts  $\pm$  1 volt



EXC-USA 200 05

wiring diagramm

main harness

548.11.075.000

20.02.2004

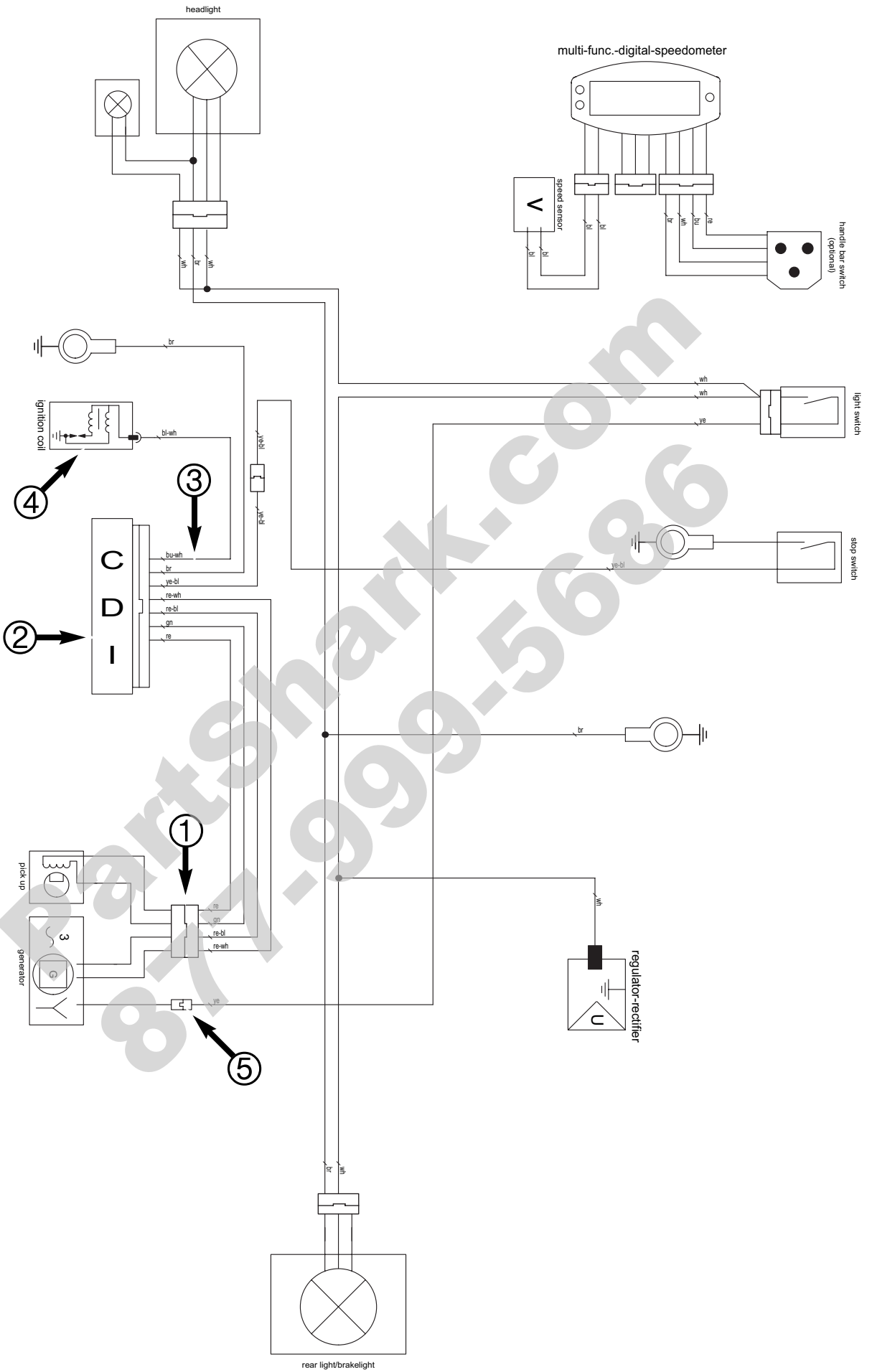

Art.-Nr. 3.206.062-E

Repair manual KTM 125 / 144 / 150 / 200

**PartShark.com**  
**877-999-5686**



# FUEL SYSTEM

# 8

## INDEX

<b>OPERATING RANGES OF THE CARBURETOR</b> .....	<b>.8-2</b>
<b>CARBURETOR ADJUSTMENT</b> .....	<b>.8-3</b>
<b>DISMOUNTING AND INSTALLING THE CARBURETOR</b> .....	<b>.8-6</b>
<b>DISASSEMBLING THE CARBURETOR</b> .....	<b>.8-8</b>
<b>CHECKING THE JET NEEDLE AND THROTTLE SLIDE</b> .....	<b>.8-9</b>
<b>CHECKING THE STARTING PISTON</b> .....	<b>.8-9</b>
<b>CHECKING THE FLOAT NEEDLE VALVE</b> .....	<b>.8-9</b>
<b>CHECKING THE CARBURETOR JETS AND GASKETS</b> .....	<b>.8-10</b>
<b>ASSEMBLING THE CARBURETOR</b> .....	<b>.8-10</b>
<b>DRAINING THE CARBURETOR FLOAT CHAMBER</b> .....	<b>.8-11</b>
<b>CHECKING THE FLOAT LEVEL</b> .....	<b>.8-11</b>

**PartShark.com**  
**877-999-5686**

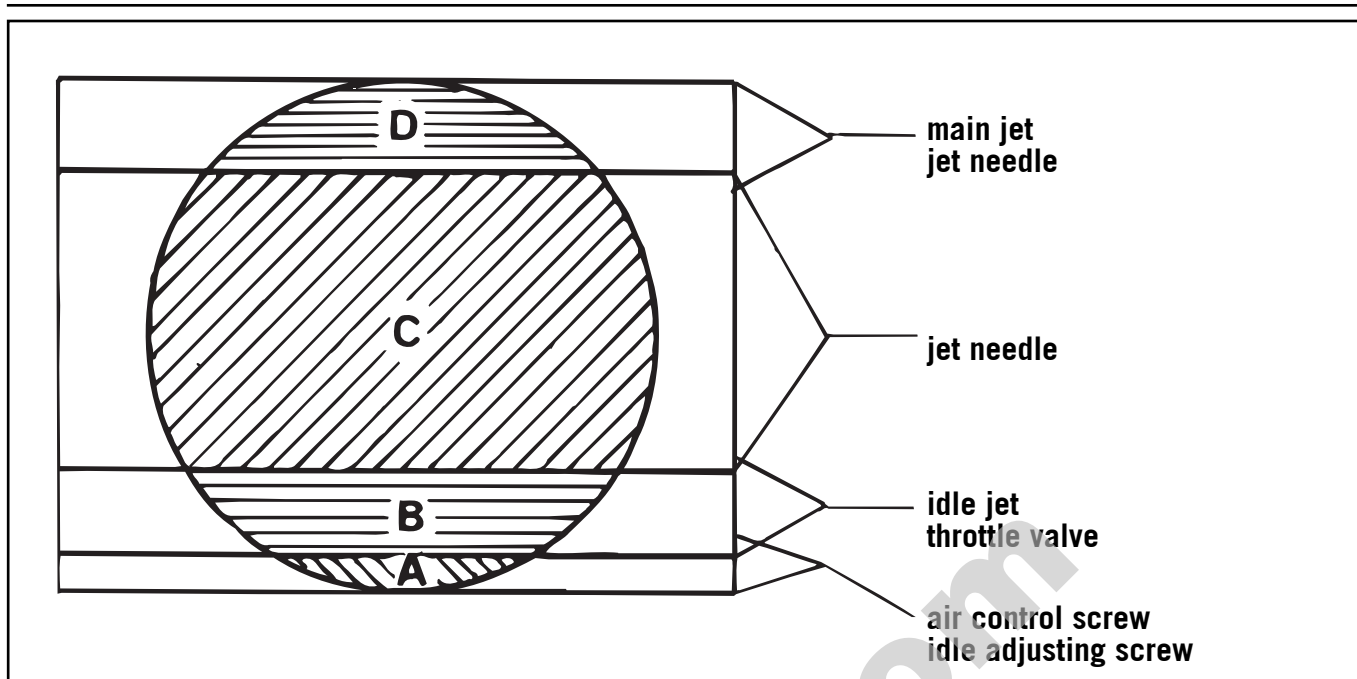

mixture too lean:

not enough fuel in proportion to air

mixture too rich:

too much fuel in proportion to air

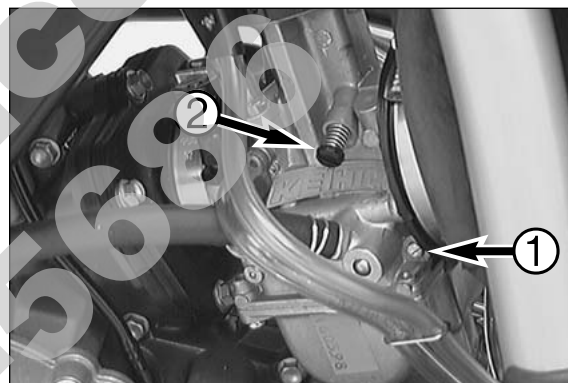

### Idling range A

Operation with closed throttle valve. This range is influenced by the position of the air control screw ❶ and the idle adjusting screw ❷. Only make adjustments when the engine is hot.

To adjust, slightly decrease the idling speed of the engine by means of the idle adjusting screw. Turning it clockwise produces a higher idling speed and turning the screw counterclockwise produces a lower idling speed. Create a round and stable engine speed using the air control screw (basic position of the air control screw = open by 1.5 turns and 1,25 on EXE and Supermoto). Then adjust to the normal idling speed by means of the idle adjusting screw.

### Opening up B

Engine behavior when the throttle opens. The idle jet and the shape of the throttle valve influences this range. If, despite good idling-speed and part-throttle setting, the engine sputters and smokes when the throttle is fully opened and develops its full power not smoothly but suddenly at high engine speeds, the mixture to the carburetor will be too rich, the fuel level too high or the float needle is leaking.

### Part-throttle range C

Operation with partly open throttle valve. This range is only influenced by the jet needle (shape and position). The optimum part-throttle setting is controlled by the idling setting in the lower range and by the main jet in the upper range. If the engine runs on a four-stroke cycle or with reduced power when it is accelerated with the throttle partly open, the jet needle must be lowered by one notch. If then the engine pings, especially when accelerating under full power at maximum engine revs, the jet needle should be raised.

If these faults should occur at the lower end of the part throttle range at a four-stroke running, make the idling range leaner; if the engine pings, adjust the idling range richer.

### Full throttle range D

Operation with the throttle fully open (flat out). This range is influenced by the main jet and the jet needle. If the porcelain of the new spark plug is found to have a very bright or white coating or if the engine rings, after a short distance of riding flat out, a larger main jet is required. If the porcelain is dark brown or black with soot the main jet must be replaced by a smaller one.

**Carburetor adjustment**

**Basic information on the original carburetor setting**

The original carburetor setting was adapted for an altitude of approx. 500 meters (1600 ft.) above sea level, and the ambient temperature of approx. 20° C (68° F), mainly for off-road use and central European premium-grade fuel (see **Technical Specifications**).

**Mixing ratio 2-stroke motor oil: super fuel 1:40 - 1:60 (see Technical Specifications)**

**Basic information on a change of the carburetor setting**

Always start out from the original carburetor setting. Essential requirements are a clean air filter system, air-tight exhaust system and an intact carburetor. Experience has shown that adjusting the main jet, the idling jet and the jet needle is sufficient and that changes of other parts of the carburetor will not greatly affect engine performance.

**RULE OF THUMB:**

- high altitude or high temperatures      ⇨      choose leaner carburetor adjustment
- low altitude or low temperatures        ⇨      choose richer carburetor adjustment



**WARNING**



- ONLY USE PREMIUM-GRADE GASOLINE (125: ROZ 98 / 200: ROZ 95) MIXED WITH HIGH-GRADE TWO-STROKE ENGINE OIL. OTHER TYPES OF GASOLINE CAN CAUSE ENGINE FAILURE, AND VOID YOUR WARRANTY.
- ONLY USE HIGH-GRADE 2-STROKE ENGINE OIL OF KNOWN BRANDS.
- NOT ENOUGH OIL OR LOW-GRADE OIL CAN CAUSE EROSION OF THE PISTON. USING TOO MUCH OIL, THE ENGINE CAN START SMOKING AND FOUL THE SPARK PLUG.
- IN THE CASE OF A LEANER ADJUSTMENT OF THE CARBURETOR PROCEED CAUTIOUSLY. ALWAYS REDUCE THE JET SIZE IN STEPS OF ONE NUMBER TO AVOID OVERHEATING AND PISTON SEIZURE.

NOTE: If despite a changed adjustment the engine does not run properly, look for mechanical faults and check the ignition system.

**Basic information on carburetor wear**

Engine vibrations subject the throttle slide, float needle, jet needle and the needle jet to extreme wear. Wear leads to malfunctioning of the carburetor (e.g. over-enrichment). These parts should be replaced after 100 operating hours. The carburetor body, main jet holder and the float support should be replaced after 200 operating hours.

jet needle	throttle valve open	effect
<b>NOZ C</b>	0 - 1/4	
<b>NOZ D</b>	0 - 1/4	⊖
<b>NOZ E</b>	0 - 1/4	⊖⊖
<b>NOZ F</b>	0 - 1/4	⊖⊖⊖
<b>NOZ G</b>	0 - 1/4	⊖⊖⊖⊖
<b>NOZ H</b>	0 - 1/4	⊖⊖⊖⊖⊖
<b>NOZ I</b>	0 - 1/4	⊖⊖⊖⊖⊖⊖
<b>NOZ J</b>	0 - 1/4	⊖⊖⊖⊖⊖⊖⊖
<b>NOZ K</b>	0 - 1/4	⊖⊖⊖⊖⊖⊖⊖⊖

**Explanation - Example**

Compared to the needle NOZ D, the jet needle NOZ F is two steps leaner in the range from the closed position of the throttle to 1/4 throttle. Otherwise, there are no differences.

<b>NOZ F</b>	0 - 1/4	⊖ ⊖
--------------	---------	-----

jet needle	throttle valve open	effect
<b>R 1466D</b>	0 - 1/4	
<b>R 1467D</b>	0 - 1/4	⊖
<b>R 1468D</b>	0 - 1/4	⊖⊖
<b>R 1469D</b>	0 - 1/4	⊖⊖⊖
<b>R 1470D</b>	0 - 1/4	⊖⊖⊖⊖
<b>R 1471D</b>	0 - 1/4	⊖⊖⊖⊖⊖

**Explanation - Example**

Compared to the needle R 1467D, the jet needle R 1469D is two steps leaner in the range from the closed position of the throttle to 1/4 throttle. Otherwise, there are no differences.

<b>R 1469D</b>	0 - 1/4	⊖ ⊖
----------------	---------	-----

jet needle	throttle valve open	effect
<b>R 1466G</b>	0 - 1/4	
<b>R 1467G</b>	0 - 1/4	⊖
<b>R 1468G</b>	0 - 1/4	⊖⊖
<b>R 1469G</b>	0 - 1/4	⊖⊖⊖
<b>R 1470G</b>	0 - 1/4	⊖⊖⊖⊖

**Explanation - Example**

Compared to the needle R 1467G, the jet needle R 1469G is two steps leaner in the range from the closed position of the throttle to 1/4 throttle. Otherwise, there are no differences.

<b>R 1469G</b>	0 - 1/4	⊖ ⊖
----------------	---------	-----

# CARBURETOR KEIHIN PWK 36S AG

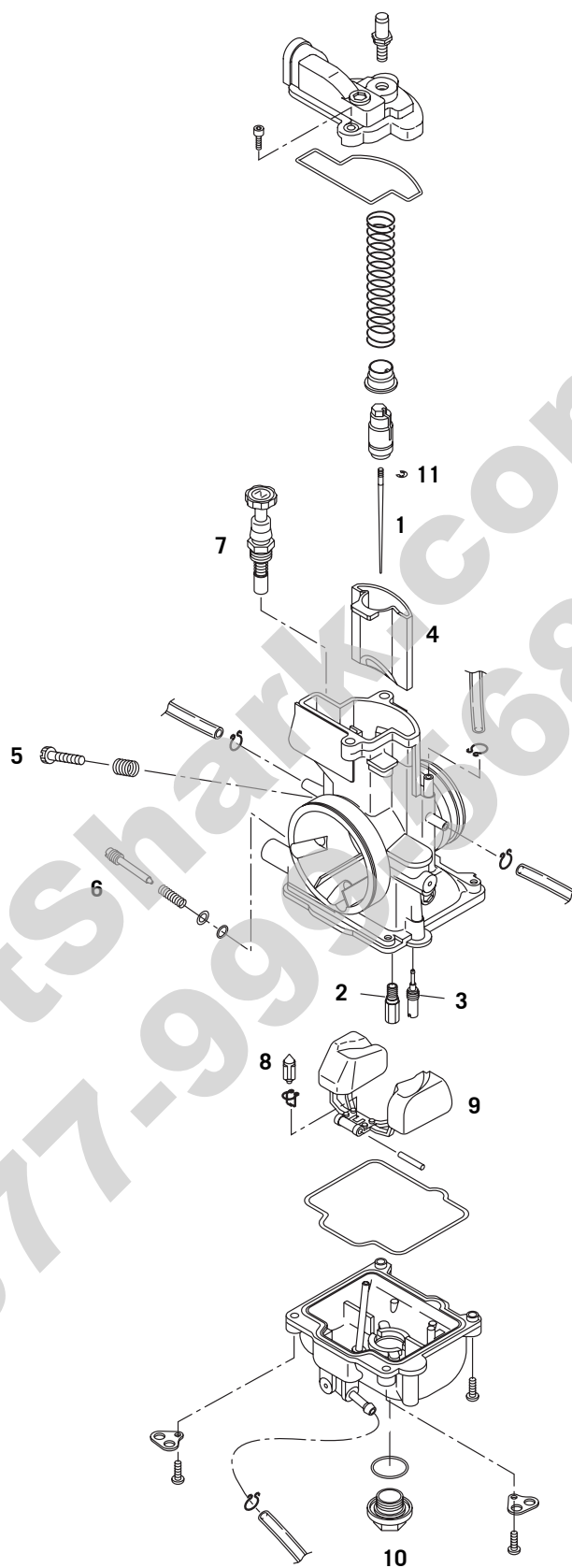

**DESIGNATION:**

1 Jet needle  
 2 Main jet  
 3 Idling jet  
 4 Throttle slide

5 Idle adjusting screw  
 6 Air control screw  
 7 Choke  
 8 Float needle

9 Float  
 10 Plug  
 11 Clamping spring

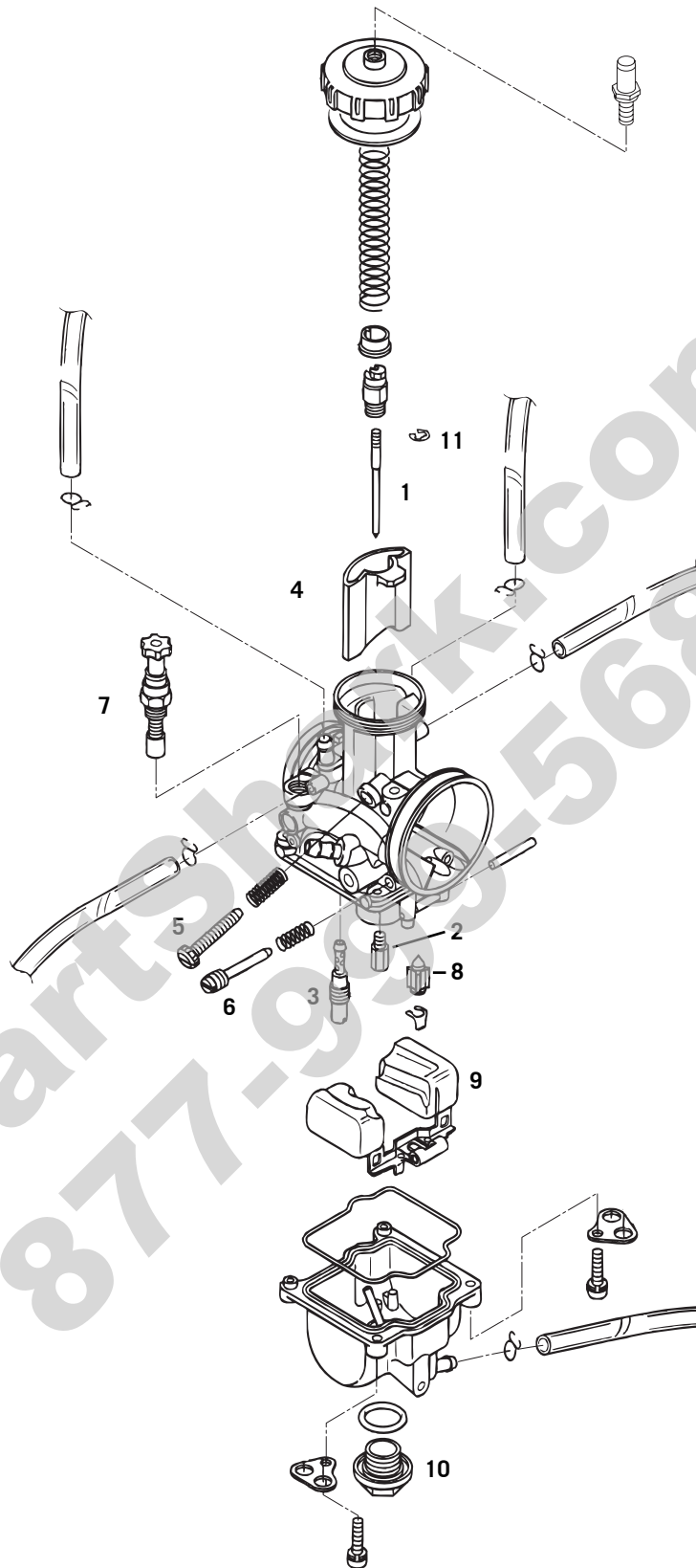
# CARBURETOR KEIHIN PWK 38AG, PWK 39

**DESIGNATION:**

1 Jet needle  
 2 Main jet  
 3 Idling jet  
 4 Throttle slide

5 Idle adjusting screw  
 6 Air control screw  
 7 Choke  
 8 Float needle

9 Float  
 10 Plug  
 11 Clamping spring

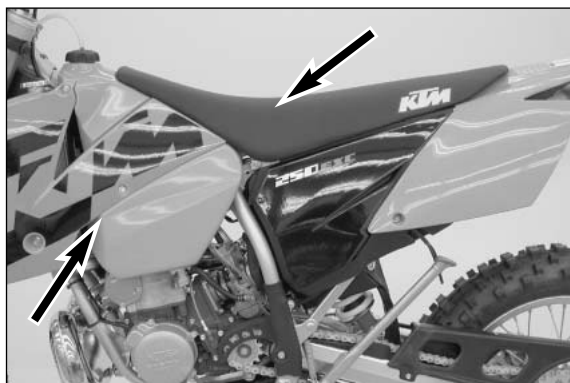

## Dismounting and installing the carburetor

NOTE: Before you start working on the carburetor, you should clean the motorcycle thoroughly.

- Dismount the seat and the tank with spoilers.

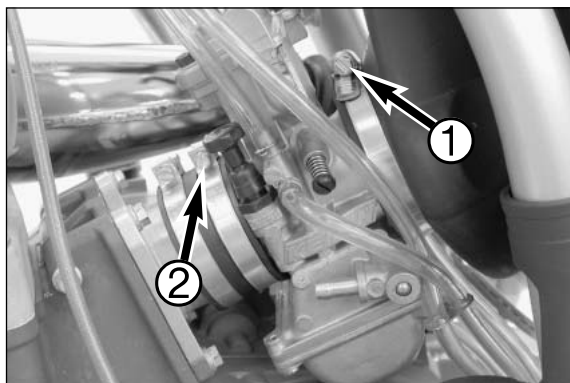

- Loosen the 2 hose clamps ① + ② and pull the carburetor out of the connection boot.

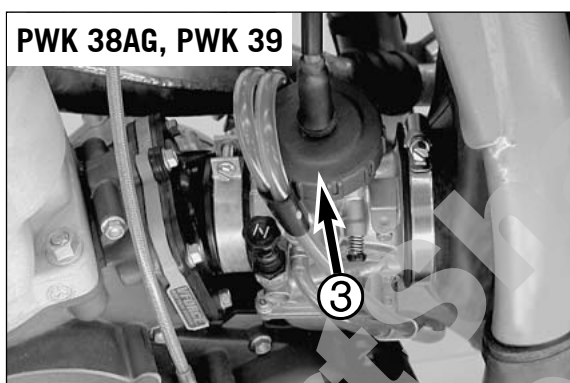

- Unscrew the carburetor cover ③ and remove the carburetor cover together with the throttle slide.

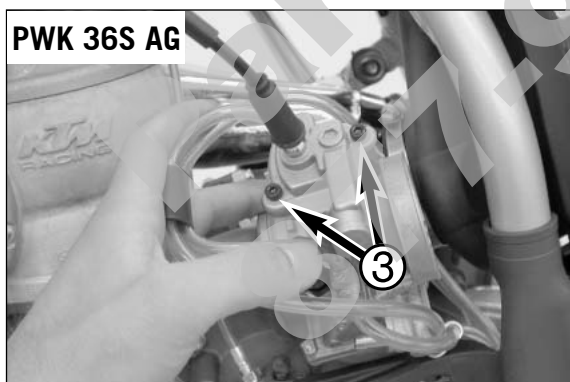

- Unscrew the two screws ③ and remove the carburetor cover together with the throttle slide.

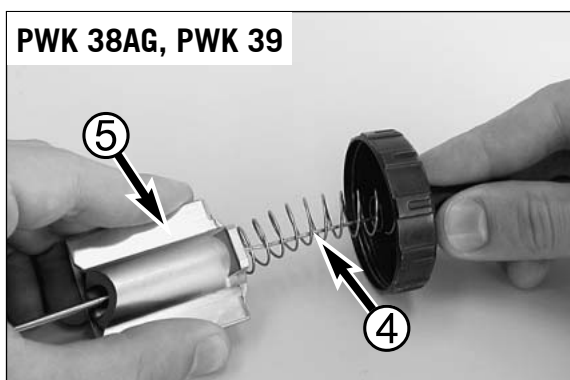

- Press the slide spring ④ together and detach the throttle cable from the throttle slide ⑤.

## PWK 36S AG

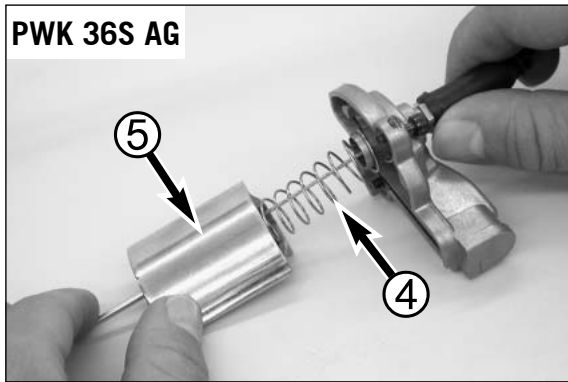

- Press the slide spring ④ together and detach the throttle cable from the throttle slide ⑤.

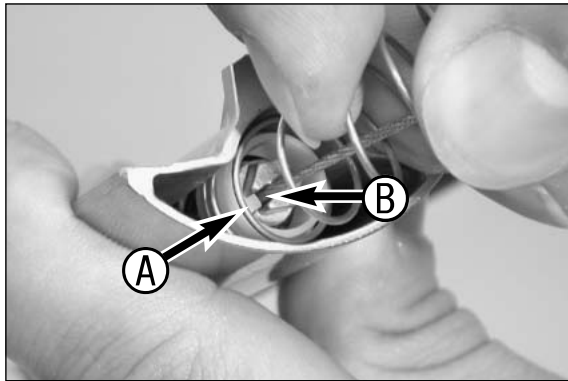

- When remounting, make sure that the tab A on the spring retainer engages in the nipple groove B.
- To mount, insert the carburetor in the boots and fix with the 2 hose clamps. Make sure the carburetor is mounted in a position vertical to the motorcycle and does not touch the engine housing.
- Mount the tank and the seat.
- Place the carburetor ventilation hoses correctly.
- Start the engine and check the carburetor for proper functioning. Turn the handlebar all the way to the left and right. The engine speed should not change, otherwise check whether the throttle cable has been placed correctly.

PartShark.com  
877-999-5686



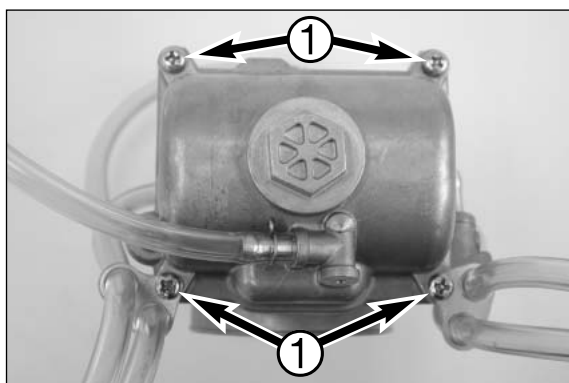

## Disassembling the carburetor

NOTE: Before you start disassembling the carburetor, you should look for a clean workplace. It should offer you enough space to lay out all individual components of the carburetor in perfect order.

- Dismount the carburetor and remove any coarse dirt.
- Loosen the four screws **1** on the float chamber and detach all of the vent hoses from the carburetor.
- Remove the float chamber **2**.

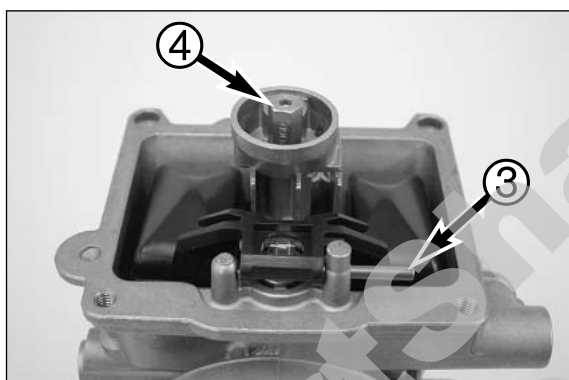
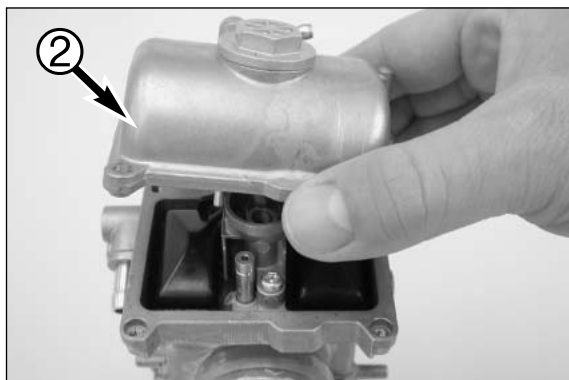

- Pull out the float hinge pin **3** and remove the float together with the float needle valve.
- Remove the main jet **4**.

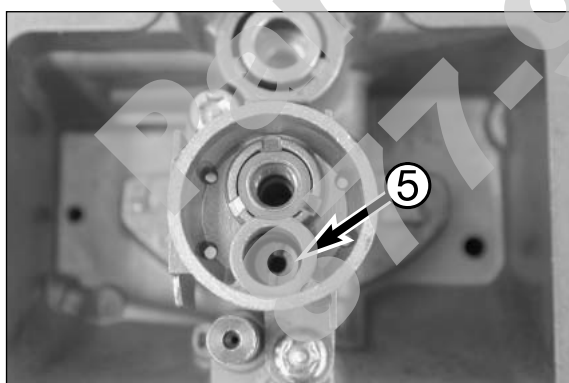

- Remove the idling jet **5**.

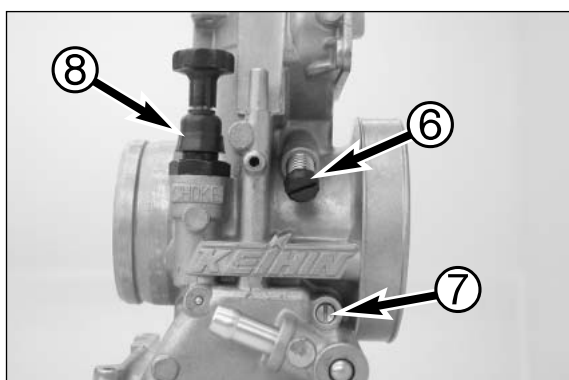

- Unscrew the idle adjusting screw **6** together with the spring and remove.
- Screw the air control screw **7** all the way in, counting and making a note of the number of turns.

PWK 36S AG:

- Unscrew the air control screw and remove it together with the spring, washer and O-ring.

PWK 38 AG, PWK 39AG:

- Unscrew the air control screw and remove it together with the spring.

- Unscrew the starting piston **8**.



- Remove the nipple ② in the throttle slide ③ to be able to remove the jet needle ①.

### PWK 38AG, PWK 39

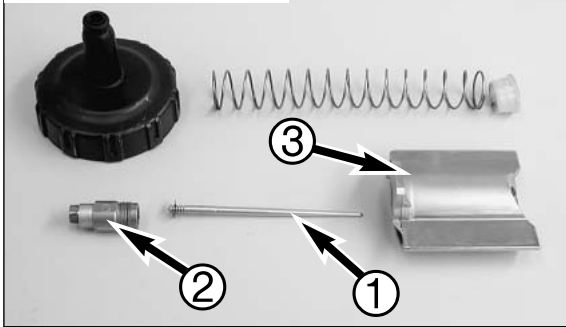

### Checking the jet needle and throttle slide

#### Jet needle:

Check the jet needle for bending and wear.

#### Throttle slide:

Check for damage and wear.

NOTE: engine vibrations subject the throttle slide, float needle, jet needle and the needle jet to extreme wear. Wear leads to malfunctioning of the carburetor (e.g. over-enrichment). These parts should be replaced after 100 operating hours. The carburetor body, main jet holder and the float support should be replaced after 200 operating hours.

### PWK 36S AG

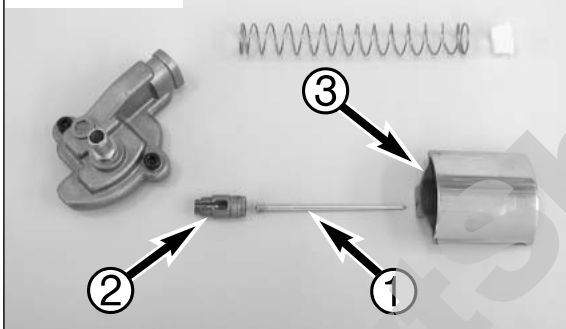

### Checking the starting piston

The starting piston should be easy to operate.

The piston ④ may not have any extreme scores or deposits.



### Checking the float needle valve

Check the sealing surface of the needle valve for notches.

There must not be any dirt between the valve seat and the float needle.

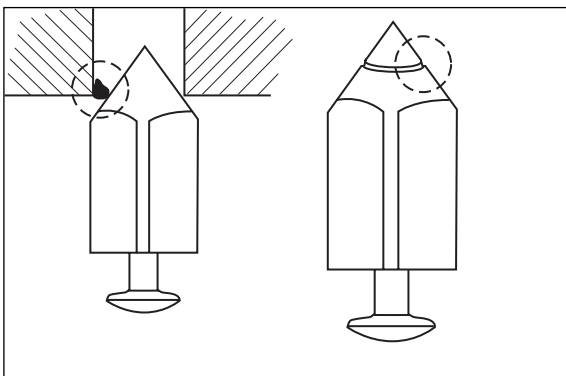

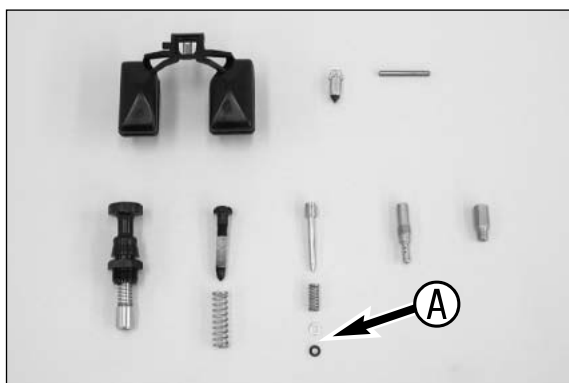

### Checking the carburetor jets and gaskets

- Thoroughly clean all jets and other parts and blow compressed air through them.
- Clean the carburetor housing and blow compressed air through all the ducts in the carburetor.
- Check all gaskets for damage and, replace them if necessary.
- Parts **A** (washer and O-ring) are only used with the carburetor PWK 36S AG.

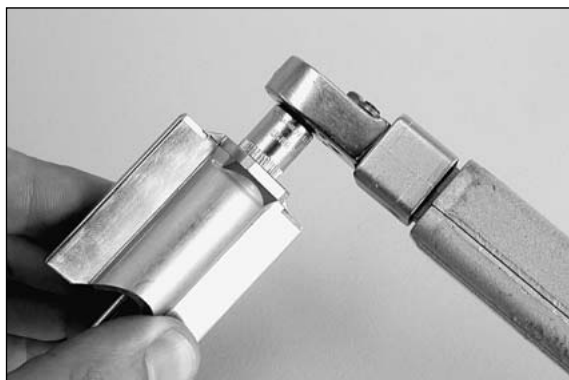

### Assembling the carburetor

- Insert the jet needle and clamping spring in the throttle side, screw on the nipple and tighten to 4Nm.

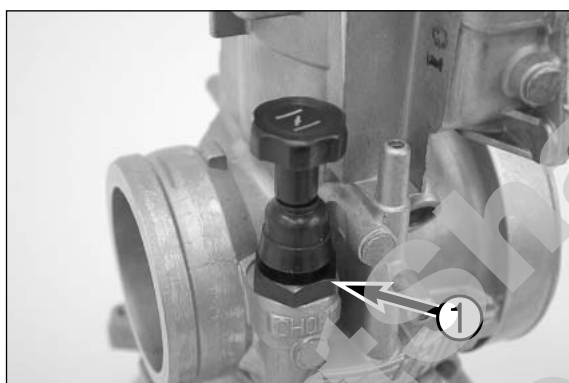

- Mount the starting piston **1** and actuate several times, checking for smooth operation. Also check whether the starting piston locks correctly.

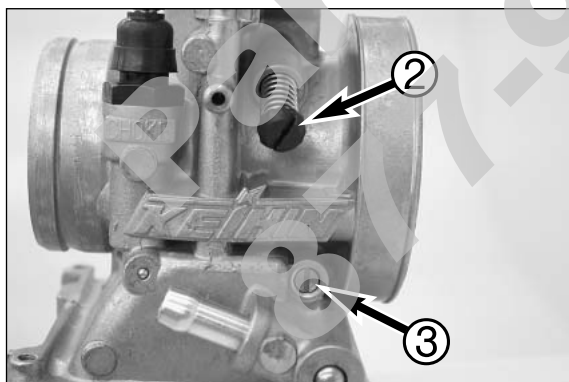

- Mount the idle adjusting screw **2** and spring.

PWK 36S AG:

- Mount the spring, washer and O-ring on the air control screw **3** and screw it all the way in.

PWK 38 AG, PWK 39AG:

- Place the spring on the air control screw **3** and screw it all the way in.

- Turn the air control screw back the number of turns that you noted down when it was dismantled.

NOTE: See the Technical Specifications for the basic carburetor setting.

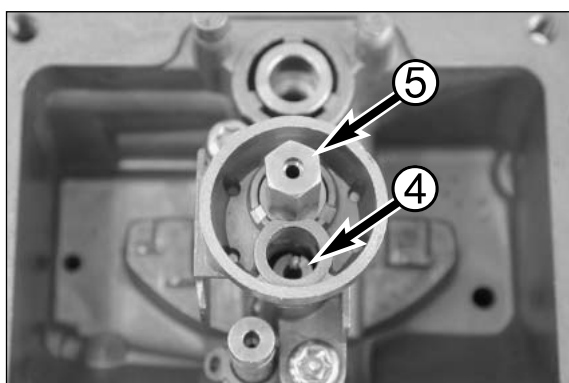

- Mount the idling jet **4** and the main jet **5**.

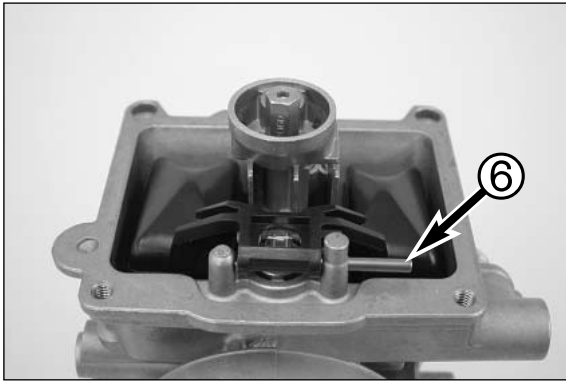

- Position the float and the float needle valve and mount the float hinge pin ⑥.
- Check the float level.

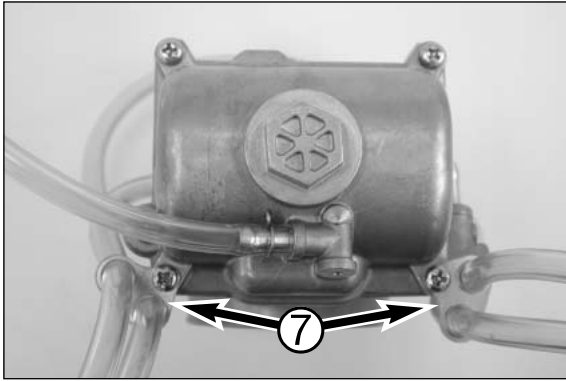

- Mount all of the vent hoses and position the retaining brackets ⑦.
- Mount the float chamber together with the retaining brackets.

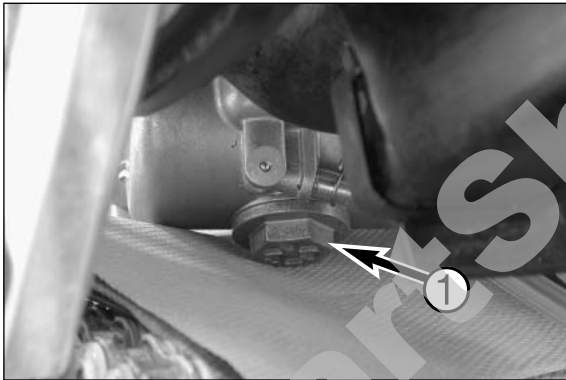

#### Draining the carburetor float chamber

- Close the fuel tap and place a cloth under the carburetor to catch any draining fuel.
- Open the plug ①, drain the remaining gasoline from the float chamber and clean the plug with compressed air.
- Mount the plug and gasket, tighten to 4 Nm, open the fuel tap and check the float housing for leaks.

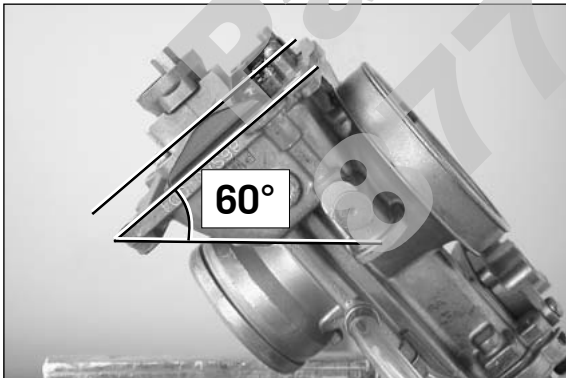

#### Checking the float level

- Arrange the carburetor diagonally at about 60° so that the spring in the float needle valve is not pressed together.
- In this position, the edge of the float should be parallel with the float chamber sealing surface (see illustration).

# TROUBLE SHOOTING

# 9

## INDEX

TROUBLE SHOOTING 125 / 144 / 150 / 200 .....	9-2
--	-----

PartShark.com  
877-999-5686

**PartShark.com**  
**877-999-5686**

## TROUBLE SHOOTING

If you let the specified maintenance work on your motorcycle be carried out, disturbances can hardly be expected. Should an error occur nevertheless, we advise you to use the trouble shooting chart in order to find the cause of error.

TROUBLE	CAUSE	REMEDY
Engine fails to start	Operating error  Fuel supply interrupted  Electrode distance too great  Plug fouled by oil, wet or bridged  Ignition wire or spark plug connector damaged  Kill button wire or short-circuit switch faulty  Loose ignition cable connectors  Spark too weak  Water in the carburetor and jets blocked	Open fuel tap, switch on ignition, refill fuel, do not use choke  Close fuel tap, loosen fuel hose at carburettor, lead into a basin and open fuel tap, – if fuel leaks out, clean carburettor – if no fuel leaks out, check tank ventilation, i.e. clean fuel tap  Reduce electrode distance (0.60 mm)  Clean spark plug or renew  Dismount spark plug, connect ignition cable, hold to ground (blank place on engine) and kick the kickstarter, a strong spark must be produced at the spark plug – If no spark is produced, loosen spark plug cap from ignition cable, hold about 5 mm from ground and kick the kickstarter – If a spark is produced, replace spark plug cap – If no spark is produced, check the ignition system  Disconnect yellow-black coloured cable from CDI and check ignition spark. If the spark is O.K. repair defective part of the cable, ignition lock or ignition switch  Inspect cable connectors  Examine ignition system  Dismantle and clean carburetor
Engine fails to idle	Idle adjusting screw out of adjustment  Ignition system damaged  Wear	Readjust idle running or replace idle adjusting screw  Examine ignition system  Overhaul engine
Engine lacks power	Charred glass fiber yarn in silencer  Air filter blocked  Control flap does not work  Fuel supply partly interrupted or blocked  Loss of compression through loose spark plug  Exhaust system damaged  Engine ignition timing faulty	Renew filling  Clean or renew airfilter  Check control flap, joint rod and centrifugal timer  Blow through fuel pipe and clean carburetor  Tighten spark plug  Check exhaust system for damage  Check and adjust ignition

TROUBLE	CAUSE	REMEDY
Engine lacks power	Reed paddles tensionless or damaged, surface of reed valve housing damaged  Wear  Electronical ignition timing faulty	Replace reed paddles or reed valve housing  Overhaul engine  Have ignition system checked
Engine does not rev high	Carburetor overflows if level is adjusted too high, float needle seating is dirty or enlarged  Loose carburetor jets	Clean carburetor, if necessary replace float needle and adjust level  Tighten jets
High rpm misfiring	Incorrect heat range spark plug or low quality spark plug  Incorrect or faulty spark plug connector  Loose, corroded or non conductive ignition socket connector	Refer to technical data section  Test and/or replace spark plug connectors with correct type  Check and seal with silicon
Engine splutters	Lack of fuel  Spark plug with incorrect heat value (Ignition by incandescence)  Engine takes air out of control	Clean fuel pipes, examine tank aeration and clean  Fit correct spark plug  Check intake flange and carburetor if firmly setted
Engine overheating	Insufficient liquid in cooling system  Cooling system not or insufficiently bled  Radiator fins clogged  Frothing in cooling system  Pinched or kinked water hoses  Incorrect ignition timing because of loose stator bolts  Incorrect dimension "X"	Top up coolant and check cooling system for leaks  Bleed cooling system (see operating instructions)  Clean radiator with water jet  Renew coolant using branded anti-freeze/anti-corrosive  Replace with correct routed hoses  Readjust to correct ignition timing specifications, secure bolts properly with Loctite 243  Measure and adjust to correct specifications
Emission of white smoke (steam)	Cylinder head or cylinder head gasket leaks	Check cylinder head, replace cylinder head gasket
Excessive oil escapes from transmission breather tube	Excessive oil quantity in transmission  Water pump shaft seal ring or right-hand crankshaft seal ring defect	Correct transmission oil level  Replace shaft seal ring and change gear oil, check coolant
All switched on lamps blown out	Voltage regulator faulty	Check control connections of voltage regulator.



# TECHNICAL SPECIFICATIONS

# 10

## INDEX

<b>MODEL 1999</b>	
<b>ENGINE 125/200</b> .....	10-3
<b>CHASSIS 125/200</b> .....	10-5
<b>ENGINE 200 ONLY SINGAPORE</b> .....	10-6
<b>MODEL 2000</b>	
<b>ENGINE 125 EXE, SUPERMOTO</b> .....	10-7
<b>CHASSIS 125 EXE, SUPERMOTO</b> .....	10-8
<b>ENGINE 125/200 SX, MXC, EXC</b> .....	10-9
<b>CHASSIS 125/200 SX, MXC, EXC</b> .....	10-11
<b>MODEL 2001</b>	
<b>ENGINE 125 EXE, SUPERMOTO</b> .....	10-7
<b>CHASSIS 125 EXE, SUPERMOTO</b> .....	10-8
<b>ENGINE 125/200 SX, MXC, EXC</b> .....	10-12
<b>CHASSIS 125/200 SX, MXC, EXC</b> .....	10-14
<b>MODEL 2002</b>	
<b>ENGINE 125/200</b> .....	10-15
<b>CHASSIS 125/200</b> .....	10-17
<b>MODEL 2003</b>	
<b>ENGINE 125/200</b> .....	10-18
<b>CHASSIS 125/200</b> .....	10-20
<b>MODEL 2004</b>	
<b>ENGINE 125/200</b> .....	10-22
<b>CHASSIS 125/200</b> .....	10-24
<b>MODEL 2005</b>	
<b>ENGINE 125/200</b> .....	10-26
<b>CHASSIS 125/200</b> .....	10-28
<b>MODEL 2006</b>	
<b>ENGINE 125</b> .....	10-30
<b>ENGINE 200</b> .....	10-31
<b>CHASSIS 125</b> .....	10-33
<b>CHASSIS 200</b> .....	10-34

**PartShark.com**  
**877-999-5686**

# TECHNICAL SPECIFICATIONS

# 10

## INDEX

<b>MODEL 2007</b>	
ENGINE 125/144 .....	10-36
ENGINE 200 .....	10-37
CHASSIS 125/144 .....	10-39
CHASSIS 200 .....	10-40
<b>MODEL 2008</b>	
ENGINE 125/144 .....	10-42
ENGINE 200 .....	10-43
CHASSIS 125/144 SX .....	10-46
CHASSIS 125/200 XC/XC-W, EXC .....	10-47
<b>MODEL 2009/2010</b>	
ENGINE 125/150 SX/XC USA .....	10-49
ENGINE 125/200 EXC/EXC SIX DAYS, 200 XC/XC-W/EXC .....	10-50
CHASSIS 125/150 SX/XC USA .....	10-52
CHASSIS 125/200 XC/XC-W, EXC/EXC SIX DAYS .....	10-53
<b>CARBURATOR SPECIFICATION</b>	
MODEL 1999 .....	10-56
MODEL 2000 .....	10-59
MODEL 2001 .....	10-62
MODEL 2002 .....	10-65
MODEL 2003 .....	10-68
MODEL 2004 .....	10-72
MODEL 2005 .....	10-76
MODEL 2006 .....	10-79
MODEL 2007 .....	10-82
MODEL 2008 .....	10-86
MODEL 2009 .....	10-90
MODEL 2010 .....	10-90

**PartShark.com**  
**877-999-5686**

## TECHNICAL DATA - ENGINE 125 / 200 '99

Engine	125 SX	125 EXC	125 EGS	200 MXC	200 EXC, EGS																																			
Design	Liquid-cooled single-cylinder two-stroke engine with intake and exhaust control																																							
Piston displacement	124.8 ccm																																							
Bore / stroke	54.25 / 54 mm (2.136 / 2.126 in) 64 / 60 mm (2.52 / 2.362 in)																																							
Fuel	SUPER fuel, research octane no 98, mixed with high grade two stroke oil SUPER fuel, research octane no 95, mixed with high grade two stroke oil																																							
Oil / gasoline ratio	1:40 when using high grade two stroke oil (Shell Advance Racing X). When in doubt, please contact your importer																																							
Crankshaft bearing	1 deep-groove ball bearing / 1 cylinder roller bearing																																							
Conrod bearing	needle bearing																																							
Piston pin bearing	needle bearing																																							
Piston	cast piston																																							
Piston ring	one plain compression ring two plain compression rings																																							
Dimension "X" <small>(upper edge piston - upper edge cylinder)</small>	0.60 mm (0.024 in) 0.55 mm (0.022 in)																																							
Ignition timing	1.4 mm (0.055 in) (16.5°) BTDC 1.6 mm (0.063 in) (17°) BTDC																																							
Spark plug	NGK R 6918-B8 NGK BR 8 EG																																							
Electrode gap	0.60 mm (0.024 in)																																							
Dimension "Z" <small>(height of the control flap)</small>	42 mm (1.65 in) 46 mm (1.81 in)																																							
Primary drive	straight cut spur gears, primary ratio 23:73																																							
Clutch	multiple disc clutch in oil bath, hydraulic operated (Shell HF-E15)																																							
Transmission	6 speed, claw actuated																																							
Gear ratio	<table style="width: 100%; border-collapse: collapse;"> <tr> <td style="width: 20%;"></td> <td style="width: 20%;">13 : 32</td> <td style="width: 20%;">12 : 33</td> <td style="width: 20%;">13 : 32</td> <td style="width: 20%;">12 : 33</td> </tr> <tr> <td>1st gear</td> <td>15 : 30</td> <td>15 : 31</td> <td>15 : 30</td> <td>15 : 31</td> </tr> <tr> <td>2nd gear</td> <td>17 : 28</td> <td>17 : 28</td> <td>17 : 28</td> <td>17 : 28</td> </tr> <tr> <td>3rd gear</td> <td>19 : 26</td> <td>19 : 26</td> <td>19 : 26</td> <td>19 : 26</td> </tr> <tr> <td>4th gear</td> <td>21 : 25</td> <td>21 : 25</td> <td>21 : 25</td> <td>21 : 25</td> </tr> <tr> <td>5th gear</td> <td>22 : 24</td> <td>20 : 20</td> <td>22 : 23</td> <td>22 : 20</td> </tr> <tr> <td>6th gear</td> <td></td> <td></td> <td></td> <td></td> </tr> </table>						13 : 32	12 : 33	13 : 32	12 : 33	1st gear	15 : 30	15 : 31	15 : 30	15 : 31	2nd gear	17 : 28	17 : 28	17 : 28	17 : 28	3rd gear	19 : 26	19 : 26	19 : 26	19 : 26	4th gear	21 : 25	21 : 25	21 : 25	21 : 25	5th gear	22 : 24	20 : 20	22 : 23	22 : 20	6th gear				
	13 : 32	12 : 33	13 : 32	12 : 33																																				
1st gear	15 : 30	15 : 31	15 : 30	15 : 31																																				
2nd gear	17 : 28	17 : 28	17 : 28	17 : 28																																				
3rd gear	19 : 26	19 : 26	19 : 26	19 : 26																																				
4th gear	21 : 25	21 : 25	21 : 25	21 : 25																																				
5th gear	22 : 24	20 : 20	22 : 23	22 : 20																																				
6th gear																																								
Gear lubrication	0.7 l engine oil 20W-40 (Shell Advance VSX4)																																							
Available chain sprockets	13t / 14t / 15t for chain $\frac{5}{8} \times \frac{1}{4}$ "																																							
Coolant	1.2 litres, 40% anti freeze, 60% water, at least -25 °C (-13 °F)																																							
Ignition system	KOKUSAN 2K-1	USA: KOKUSAN 2K-2 EU: 2K-3	KOKUSAN 2K-3	KOKUSAN 2K-2	KOKUSAN 2K-3																																			
Generator output	no generator	12V 40 W	12V 110 W	12V 40 W	12V 110 W																																			
Carburetor	flat-slide carburetor, carburetor setting see table																																							
Air-filter	wet foam type air filter insert																																							

TOLERANCES AND FITTING CLEARANCES		
Piston fitting clearance	125 = 0.06 mm	200 = 0.085 mm
Piston ring end cap	max. 0.40 mm	
Connecting rod bearing - radial clearance	0.025–0.035 mm	
Transmission shafts end float	0.20–0.40 mm	
Clutch springs - length	new = 39 mm, minimum length = 38 mm	

TIGHTENING TORQUES			
Flange bolts - cylinder-head	M 7	18 Nm	(14 ft. lb)
Nuts-cylinder base	M 8	30 Nm	(22 ft. lb)
Flywheel collar nut	M 12x1	60 Nm	(44 ft. lb)
Nut for primary sprocket (LH thread)	M 16x1.5	180 Nm	(133 ft. lb)
Nut for inner clutch hub	M 18x1.5	120 Nm	(88 ft. lb)
Crankcase and clutch cover bolts	M 6	8 Nm	(6 ft. lb)
Spark plug	M 14x1.25	20 Nm	(14 ft. lb)
Nut swingarm pivot	M 14x1.5	100 Nm	(74 ft. lb)
Other bolts	M 6	10 Nm	(7 ft. lb)
	M 8	25 Nm	(19 ft. lb)
	M 10	45 Nm	(33 ft. lb)

GASKET THICKNESSES	
Crankcase	0,5 mm
Clutch cover	0,5 mm
Clutch driving cylinder	0.30 / 0.50 / 0.75 mm
Cylinder bottom gasket	as required
Available bottom gasket	0.07 / 0.15 / 0.20 / 0.25 / 0.40 / 0.50 / 0.75 mm
Cylinder-head gasket	1.10 mm + O-ring

BASIC CARBURETOR SETTING						
	125 SX, EXC USA 125 EGS AUSTRALIA	125 SX, EXC EUROPE	125 EGS	200 MXC, EXC USA	200 EXC EUROPE	200 EGS 200 EGS AUSTRALIA
Carburetor	Keihin PWK 39	Keihin PWK 39	Keihin PWK 39	Keihin PWK 39	Keihin PWK 39	Keihin PWK 39
Carburetor setting number	120598	160598	130598	140598	170598	150598
Main jet	190 (188/192/195)	190 (188/192/195)	150 (188/190/192/195)	180 (175/178/182/185)	180 (175/178/182/185)	180 (175/178/182/185)
Idling jet	48 (45/50)	48 (45/50)	45 (48/50)	45 (42/48)	45 (42/48)	45 (42/48)
Starting jet	85	85	85	85	85	85
Jetneedle	NOZH (NOZF/NOZG/NOZI)	NOZF (NOZG/NOZH/NOZI)	R1471 (NOZF/NOZG/NOZH/NOZI)	NOZH (NOZG/NOZI)	NOZG (NOZH/NOZI)	NOZH (NOZG/NOZI)
Needle position from top	III	III	IV	III	II	IV
Throttle valve	6	6	6	6	6	6
Air adjustment screw top	1,5	1,5	1,5	1,5	1,5	1,5
Performance restrictor	–	–	–	–	–	slide stop 36mm

# TECHNICAL SPECIFICATIONS CHASSIS 125 SX / EXC / EGS, 200 MXC / EXC / EGS '99

	125 SX	125 EXC	125 EGS	200 MXC	200 EXC	200 EGS
Frame	Central chrome-moly-steel frame					
Fork	WP Extreme	Marzocchi Magnum 45 Code 91				
Wheel travel front/rear	280 / 320 mm (11.0 / 12.6 in)	285 / 320 mm (11.2 / 12.6 in)				
Rear suspension	WP Progressive Damping System shock absorber, aluminium swingarm					
Front brake	Disc brake with carbon-steel brake disc Ø 260 mm (10.2 in), brake caliper floated					
Rear brake	Disc brake with carbon-steel brake disc Ø 220 mm (8.7 in), brake caliper floated					
Front tires	80/100 - 21" 51M	90/90 - 21" 54R	90/90 - 21" 54R	80/100 - 21" 51M	90/90 - 21" 54R	90/90 - 21" 54R
Air pressure offroad	1.0 bar (14psi)	1.0 bar (14psi)	1.0 bar (14psi)	1.0 bar (14psi)	1.0 bar (14psi)	1.0 bar (14psi)
Air press. road driver only	-	1,5 bar (21psi)	1,5 bar (21psi)	-	1.5 bar (21psi)	1.5 bar (21psi)
Rear tires	100/90 - 19" 57M	120/90 - 18" 65R	120/90 - 18" 65R	100/100 - 18" 59M	120/90 - 18" 65R	120/90 - 18" 65R
Air pressure offroad	1.0 bar (14psi)	1.0 bar (14psi)	1.0 bar (14psi)	1.0 bar (14psi)	1.0 bar (14psi)	1.0 bar (14psi)
Air press. road driver only	-	2.0 bar (28psi)	2.0 bar (28psi)	-	2.0 bar (28psi)	2.0 bar (28psi)
Fuel tank capacity	7.5 liter (2 US Gallons)	9.5 liter (2.5 US gallons)	9.5 or 12 liter (2.4 US gallons)	12 liter (3.2 US gallons)	9.5 or 12 liter (2.5 or 3.2 US gallons)	9.5 or 12 liter (2.5 or 3.2 US gallons)
Final drive ratio	13:50	13:50	14:38	14:48	14:48	14:38
Chain	5/8 x 1/4 "					
Available final sprockets	38, 40, 42, 45, 48, 50, 52					
Steering head angle	63°					
Wheel base	1461 ± 10 mm (57.3 ± 0,4 in)					
Seat height, unloaded	925 mm (36.4 in)					
Ground clearance, unloaded	385 mm (15,2 in)					
Dead-weight without fuel	92 kg (203 lbs)	96 kg (212 lbs)	100 kg (221 lbs)	96 kg (212 lbs)	97 kg (214 lbs)	101 kg (223 lbs)

### STANDARD ADJUSTMENT - FORK

	Marzocchi 91	WP 918T767
Compression adjuster	15	12
Rebound adjuster	15	12
Spring	4.0 N/mm	4.0 N/mm
Spring preload	10 mm (0.4in)	5 mm (0.2in)
Air chamber length	140 mm (5.5in)	150 mm (5.9in)
Capacity per fork leg	approx. 600 ccm	approx. 750 ccm
Fork oil	SAE 7.5	SAE 5

NOTE: The damping units in the left and the right fork leg are of different design. Make sure not to mix them up in case of repair or service jobs.

### STANDARD ADJUSTMENT - SHOCK ABSORBER

	WP 1218T711	WP 1218T713
Compression adjuster	5	6
Rebound adjuster	14	14
Spring	PDS2-250	PDS1-250
Spring preload	5 mm (0.2 in)	6 mm (0.23 in)

### TIGHTENING TORQUES - CHASSIS

Collar bolt front wheel spindle	M 10	40 Nm (30 ft.lb)
Brake caliper front	M 8	25 Nm (19 ft.lb) + Loctite 243
Clamping bolts upper fork bridge	M 8	15 Nm (11 ft.lb)
Clamping bolts lower fork bridge	M 8	20 Nm (15 ft.lb)
Clamping bolts fork stubs (Marzocchi)	M 6	7 Nm (5 ft.lb)
Clamping bolts fork stubs (WP Extreme)	M 8	10 Nm (7 ft.lb)
Collar nut rear wheel spindle	M 20x1.5	80 Nm (59 ft.lb)
Hexagon nut swingarm bolt	M 14x1.5	100 Nm (74 ft.lb)
Shock absorber top	M 12	60 Nm (44 ft.lb)
Shock absorber bottom	M 12	40 Nm (30 ft.lb)
Other bolts on chassis	M 6	10 Nm (7 ft.lb)
	M 8	25 Nm (19 ft.lb)
	M 10	45 Nm (33 ft.lb)

## TECHNICAL DATA - ENGINE 200 EGS ONLY SINGAPORE '99

Engine	<b>200 EGS Singapore</b>
Design	Liquid-cooled single-cylinder two-stroke engine with intake and exhaust control
Piston displacement	193 ccm
Bore / stroke	64 / 60 mm (2.52 / 2.362 in)
Fuel	SUPER fuel, research octane no 95
Lubrication	Separate lubrication
Engine oil	Shell Advance Racing X or high grade 2-stroke oil for a mixture ratio 1:50 and separate lubrication
Crankshaft bearing	1 deep-groove ball bearing / 1 cylinder roller bearing
Connecting rod bearing	needle bearing
Piston pin bearing	needle bearing
Piston	cast piston
Piston ring	two plain compression rings
Dimension "X" <small>(upper edge piston - upper edge cylinder)</small>	0.55 mm (0.22 in)
Ignition timing	1.6 mm (0.063 in) (17°) BTDC
Spark plug	NGK BR 8 EG
Electrode gap	0.60 mm (0,024 in)
Dimension "Z" <small>(height of the control flap)</small>	46 mm (1.81 in)
Primary drive	straight cut spur gears, primary ratio 23:73
Clutch	multiple disc clutch in oil bath, hydraulic operated (Shell HF-E15)
Transmission	6 speed, claw actuated
1st gear	12 : 33
2nd gear	15 : 31
3rd gear	17 : 28
4th gear	19 : 26
5th gear	22 : 25 / 17 : 19
6th gear	22 : 20
Gear lubrication	0,70 l engine oil 20W-40 (Shell Advance VSX4)
Available chain sprockets	13t / 14t / 15t for chain 5/8 x 1/4"
Coolant	1.2 litres, 40% anti freeze, 60% water, at least -25 °C (-13 °F)
Ignition system	KOKUSAN 2K-3
Generator output	12V 110 W
Carburetor	flat-slide carburetor, carburetor setting see table
Air-filter	wet foam type air filter insert

### BASIC CARBURETOR SETTING

	<b>200 EGS (Sgp)</b>
Carburetor	Keihin PWK 39
Carburetor setting number	180698
Main jet	178 (175/180/182/185)
Idling jet	42 (45/48)
Starting jet	85
Jet needle	NOZI (NOZG/NOZH)
Needle position from top	II
Throttle valve	6
Air adjustment screw top	1,5
Performance restrictor	slide stop 36 mm



## TECHNICAL DATA - ENGINE 125 EXE / 125 SUPERMOTO 2000

Engine	<b>125 EXE</b>
Design	Liquid-cooled single-cylinder two-stroke engine with intake and exhaust control
Piston displacement	124.8 ccm
Bore / stroke	54,0 / 54,5 mm (2.125 / 2.145 in)
Fuel	unleaded fuel with a least RON 91
Lubrication	separate lubrication
Oil / gasolin ratio	Shell Advance Ultra 2 or 2-stroke oil for a mix ratio1:50 and separate lubrication
Crankshaft bearing	2 grooved ball bearing
Connecting rod bearing	needle bearing
Piston pin bearing	needle bearing
Piston	cast light alloy
Piston ring	2 rectangular ring
Spark plug	NGK BR8 HS
Electrode gap	0.60 mm (0,024 in)
Primary drive	straight cut spur gears, primary ratio 23:73
Clutch	multiple disc clutch in oil bath, hydraulic operated (Shell HF-E15)
Transmission	6 speed, claw actuated
Gear ratio	
1st gear	12 : 33
2nd gear	15 : 31
3rd gear	17 : 28
4th gear	19 : 26
5th gear	21 : 25
6th gear	22 : 24
Gear lubrication	0.7 l gear oil SAE-80W (Shell Advance Gear EP)
Available chain sprockets	14t for chain $\frac{5}{8} \times \frac{1}{4}$ "
Coolant	0,8 litres, 40% anti freeze, 60% water, at least -25 °C (-13 °F)
Ignition system	Kokusai digital 2K-3
Generator output	12V / 110 W
Carburetor	flat-slide carburetor, carburetor setting see table
Air-filter	wet foam type air filter insert
Oil tank	tank content: 1,3 liter (0,34 US gallons)

Art.-Nr. 3.206.062-E

Repair manual KTM 125 / 144 / 150 / 200

### BASIC CARBURETOR SETTING

	125 EXE (80 km/h)	125 EXE (100km/h)	125 Supermoto (80 km/h)	125 Supermoto (100 km/h)
Carburetor	Dell'Orto PHBH 28	Dell'Orto PHBH 28	Dell'Orto PHBH 28	Dell'Orto PHBH 28
Carburetor setting number	051299	021199	051299	021199
Main jet	120	125	120	125
Idling jet	50	50	50	50
Starting jet	70	70	70	70
Jetneedle	X83	X83	X83	X83
Needle position from top	III	III	III	III
Throttle valve	40	40	40	40
Air adjustment screw top	1,25	1,25	1,25	1,25
Performance restrictor	-	-	-	-

# TECHNICAL SPECIFICATIONS CHASSIS 125 EXE / 125 SUPERMOTO 2000

	125 EXE	125 Supermoto
Frame	Central chrome-moly-steel frame	
Fork	White Power – Up Side Down 40 TA	
Wheel travel front/rear	220/260 mm (8,7/10,2 in)	
Rear suspension	WP Progressive Damping System shock absorber, aluminium swingarm	
Front brake	Disc brake with carbon-steel brake disc, brake caliper floated	
Front brake disc	Ø 260 mm (10,2 in)	Ø 320 mm (12,6 in)
Rear brake	Disc brake with carbon-steel brake disc Ø 220 mm (8.7 in), brake caliper floated	
Brake discs	Wear limit max. 0,4 mm (0,016 in)	
Front tires	3.00 - 21"	110/70 - 17"
Air pressure, driver only	1,8 bar (26 psi)	1,8 bar (26 psi)
Air pressure, driver plus passenger	2,0 bar (29 psi)	2,0 bar (29 psi)
Rear tires	4.60 - 18"	130/70 - 17"
Air pressure, driver only	2,0 bar (29 psi)	2,1 bar (30 psi)
Air pressure, driver plus passenger	2,2 bar (32 psi)	2,3 bar (33 psi)
Fuel tank capacity	11,0 liter (3 US Gallons), 2,5 liter (0,6 US gallons) reserve	
Final drive ratio	14:40 t	14:38 t
Chain	O-ring 5/8 x 1/4 "	
Battery	maintenance free 12V 3Ah	
Lamps	head light	H4 12V 60/55W (socket P43t)
	parking light	12V 5W (socket W2,1x9,5d)
	cockpit light	12V 2W (socket W2x4,6d)
	stop and tail light	12V 21/5W (socket BaY15d)
	flasher	12V 10W (socket Ba15s)
Steering head angle	63°	
Wheel base	1461 ± 10 mm (57,5 ± 0,4 in)	
Seat height, unloaded	865 mm (34,0 in)	830 mm (32,7 in)
Ground clearance, unloaded	290 mm (11,4 in)	255 mm (10,0 in)
Dead-weight *	104 kg (230 lbs)	
Max. permissible front axle load	145 kg (320 lbs)	
Max. permissible rear axle load	190 kg (419 lbs)	
Max. permissible laden weight	335 kg (740 lbs)	

\* Dead-weight without fuel

## STANDARD ADJUSTMENT - FORK

	WP 0618T777A
Compression adjuster	10
Rebound adjuster	9
Spring	4,2 N/mm
Spring preload	10 mm (0.4 in)
Air chamber length	140 mm (5.5 in)
Capacity per fork leg	approx. 500 ccm
Fork oil	SAE 5

## STANDARD ADJUSTMENT - SHOCK ABSORBER

	WP 1218T715
Compression adjuster	3
Rebound adjuster	14
Spring	PDS1-250
Spring preload	5 mm (0.2 in)

## TIGHTENING TORQUES - CHASSIS

Collar nut front wheel spindle	M 16x1,5	40 Nm (30 ft.lb)
Brake caliper front	M 8	25 Nm (19 ft.lb) +Loctite 243
Clamping bolts upper fork bridge	M 8	20 Nm (15 ft.lb)
Clamping bolts lower fork bridge	M 8	15 Nm (11 ft.lb)
Clamping bolts fork stubs	M8	10 Nm (7 ft.lb)
Collar nut rear wheel spindle	M 20x1.5	80 Nm (59 ft.lb)
Hexagon nut swing arm bolt	M 14x1.5	100 Nm (74 ft.lb)
Collar bolt handlebar clamp	M 8	20 Nm (15 ft.lb)
Allen head bolt handlebar support	M 10	40 Nm (30 ft.lb) +Loctite 243
Shock absorber top	M 12	60 Nm (44 ft.lb)
Shock absorber bottom	M 12	60 Nm (44 ft.lb)
Screw adjusting ring spring preload	M 6	8 Nm (6 ft.lb)
Other bolts on chassis	M 6	10 Nm (7 ft.lb)
	M 8	25 Nm (19 ft.lb)
	M 10	45 Nm (33 ft.lb)

**TECHNICAL DATA - ENGINE 125 / 200 2000**

	<b>125 SX</b>	<b>125 EXC</b>	<b>200 MXC</b>	<b>200 EXC</b>
Engine				
Design	Liquid-cooled single-cylinder two-stroke engine with intake and exhaust control			
Piston displacement	124.8 ccm			
Bore / stroke	54.25 / 54 mm (2.136 / 2.126 in)			
Fuel	unleaded SUPER fuel, research octane no 95, mixed with high grade two stroke oil 64 / 60 mm (2.52 / 2.362 in) 193 ccm			
Oil / gasolin ratio	1:40-1:60 when using high grade two stroke oil (Shell Advance Racing X). When in doubt, please contact your importer			
Crankshaft bearing	1 deep-groove ball bearing / 1 cylinder roller bearing			
Connecting rod bearing	needle bearing			
Piston pin bearing	needle bearing			
Piston	forged piston cast piston			
Piston ring	one plain compression ring two plain compression rings			
Dimension "X" <small>upper edge piston- upper edge cylinder</small>	0.60 mm (0.024 in) 0.55 mm (0.22 in)			
Ignition timing	1.4 mm (0.055 in) (16.5°) BTDC 1.6 mm (0.063 in) (17°) BTDC			
Spark plug	NGK BR9 EVX NGK BR 8 EG			
Electrode gap	0.60 mm (0.024 in)			
Dimension "Z" <small>height of the control flap</small>	42 mm (1.65 in) 46 mm (1.81 in)			
Primary drive	straight cut spur gears, primary ratio 23:73			
Clutch	multiple disc clutch in oil bath, hydraulic operated (Shell HF-E15)			
Transmission	6 speed, claw actuated			
Gear ratio				
1st gear	13 : 32	12 : 33	13 : 32	12 : 33
2nd gear	15 : 30	15 : 31	15 : 30	15 : 31
3rd gear	17 : 28	17 : 28	17 : 28	17 : 28
4th gear	19 : 26	19 : 26	19 : 26	19 : 26
5th gear	21 : 25	21 : 25	21 : 25	17 : 19
6th gear	22 : 24	20 : 20	22 : 23	22 : 20
Gear lubrication	0.7 l engine oil 20W-40 (Shell Advance VSX4)			
Available chain sprockets	13t / 14t / 15t for chain $\frac{5}{8}$ x $\frac{1}{4}$ "			
Coolant	1.2 litres, 40% anti freeze, 60% water, at least -25 °C (-13 °F)			
Ignition system	KOKUSAN 2K-1	KOKUSAN 2K-3	-	KOKUSAN 2K-3
Generator output	no generator	12V / 110 W	-	12V 110 W
Ignition system USA	KOKUSAN 2K-1		KOKUSAN 2K-2	
Generator output	no generator		12V 40 W	
Carburetor	flat-slide carburetor, carburetor setting see table			
Air-filter	wet foam type air filter insert			

TIGHTENING TORQUES - ENGINE			
Flange bolts - cylinder-head	M 7	18 Nm	(13 ft.lb)
Nuts-cylinder base	M 8	30 Nm	(22 ft.lb)
Flywheel collar nut	M 12x1	60 Nm	(44 ft.lb)
Nut for primary sprocket (LH thread)	M 16x1.5	180 Nm	(133 ft.lb)
Nut for inner clutch hub	M 18x1.5	120 Nm	(88 ft.lb)
Crankcase and clutch cover bolts	M 6	8 Nm	(6 ft.lb)
Spark plug	M 14x1.25	20 Nm	(14 ft.lb)
Other bolts	M 6	10 Nm	(7 ft.lb)
	M 8	25 Nm	(19 ft.lb)
	M 10	45 Nm	(33 ft.lb)

TOLERANCES AND FITTING CLEARANCES	
Piston fitting clearance	125 = 0.06 mm    200 = 0.085 mm
Piston ring end cap	max. 0.40 mm
Connecting rod bearing - radial clearance	0.025–0.035 mm
Transmission shafts end float	0.20–0.40 mm
Clutch springs - length	new = 39 mm, minimum length = 38 mm

GASKET THICKNESSES	
Crankcase	0,5 mm
Clutch cover	0,5 mm
Clutch driving cylinder	0.30 / 0.50 / 0.75 mm
Cylinder bottom gasket	as required
Available bottom gasket	0.07 / 0.15 / 0.20 / 0.25 / 0.40 / 0.50 / 0.75 mm
Cylinder-head gasket	1.10 mm + O-ring

BASIC CARBURETOR SETTING				
	125 SX	125/200 MXC, EXC	125 EXC throttled	200 EXC throttled
Carburetor	Keihin PWK 39	Keihin PWK 38 AG	Keihin PWK 39	Keihin PWK 38 AG
Carburetor setting number	100499	120499	030799	040799
Main jet	190 (188/192)	180 (185)	142	180
Idling jet	48 (45/50)	45 (48)	35	35
Starting jet	85	85	85	85
Jetneedle	R 1467 D (R 1468 D)	NOZ H (NOZ I)	R 1472 N	R 1475 J
Needle position from top	III	III	V	IV
Throttle valve	55	6	6	6
Air adjustment screw top	1,5	1,5	1,5	1,5
Performance restrictor	–	–	–	slide stop 36mm

# TECHNICAL SPECIFICATIONS CHASSIS 125 SX / EXC, 200 MXC / EXC 2000

	125 SX	125 EXC	200 MXC	200 EXC
Frame	Central chrome-moly-steel frame			
Fork	White Power – Up Side Down 43 MA			
Wheel travel front/rear	295/320 mm (11,3/12,6 in)			
Rear suspension	WP Progressive Damping System shock absorber, aluminium swingarm			
Front brake	Disc brake with carbon-steel brake disc Ø 260 mm (10.2 in), brake caliper floated			
Rear brake	Disc brake with carbon-steel brake disc Ø 220 mm (8.7 in), brake caliper floated			
Brake discs	Wear limit max. 0,4 mm (0,016 in)			
Front tires	80/100 - 21" 51M	90/90 - 21" 54R	–	90/90 - 21" 54R
Front tires USA	80/100 - 21" 51M	80/100 - 21" 51M	80/100 - 21" 51M	80/100 - 21" 51M
Air pressure offroad	1,0 bar (14psi)	1,0 bar (14psi)	1,0 bar (14psi)	1,0 bar (14psi)
Air pressure road driver only	–	1,5 bar (21psi)	–	1,5 bar (21psi)
Rear tires	100/90 - 19" 57M	120/90 - 18" 65R	–	120/90 - 18" 65R
Rear tires USA	100/90 - 19" 57M	100/100 - 18" 59M	100/100 - 18" 59M	100/100 - 18" 59M
Air pressure offroad	1,0 bar (14psi)	1,0 bar (14psi)	1,0 bar (14psi)	1,0 bar (14psi)
Air pressure road driver only	–	2,0 bar (28psi)	–	2,0 bar (28psi)
Fuel tank capacity	7,5 liter (2 US Gallons)	9,5 liter (2,5 US Gallons)	12 liter (3,2 US Gallons)	9,5/12 liter (2,5/3,2 US Gallons)
Final drive ratio	13:50t	14:38t	–	14:45t / 14:48t
Final drive ratio USA	13:50t	13:50t	14:48t	14:48t
Chain	5/8 x 1/4 "			
Available final sprockets	38t, 40t, 42t, 45t, 48t, 50t, 52t			
Steering head angle	63°			
Wheel base	1461 ± 10 mm (57,3 ± 0,4 in)			
Seat height, unloaded	925 mm (36,5 in)			
Ground clearance, unloaded	385 mm (15,2 in)			
Dead-weight *	92 kg (203 lbs)	100 kg (221 lbs)	–	101 kg (223 lbs)
Dead-weight USA *	92 kg (203 lbs)	96 kg (212 lbs)	96 kg (212 lbs)	97 kg (214 lbs)

\* Dead-weight without fuel

### STANDARD ADJUSTMENT - FORK

	WP 0518U783	WP 0518U784
Compression adjuster	16	14
Rebound adjuster	12	12
Spring	3,8 N/mm	3,8 N/mm
Spring preload	6 mm (0.24in)	6,5 mm (0.26in)
Air chamber length	140 mm (5.5in)	150 mm (5.9in)
Capacity per fork leg	approx. 840 ccm	approx. 830 ccm
Fork oil	SAE 5	SAE 5

### STANDARD ADJUSTMENT - SHOCK ABSORBER

	WP 1218U717	WP 1218U719
Compression adjuster	4	5
Rebound adjuster	20	20
Spring	PDS2-250	PDS1-250
Spring preload	5 mm (0.2 in)	5 mm (0.2 in)

### TIGHTENING TORQUES - CHASSIS

Collar nut front wheel spindle	M 16x1,5	40 Nm (30 ft.lb)
Brake caliper front	M 8	25 Nm (19 ft.lb) + Loctite 243
Clamping bolts upper fork bridge	M 8	20 Nm (15 ft.lb)
Clamping bolts lower fork bridge	M 8	15 Nm (11 ft.lb)
Clamping bolts fork stubs	M8	10 Nm (7 ft.lb)
Collar nut rear wheel spindle	M 20x1.5	80 Nm (59 ft.lb)
Hexagon nut swing arm bolt	M 14x1.5	100 Nm (74 ft.lb)
Collar bolt handlebar clamp	M 8	20 Nm (15 ft.lb)
Allen head bolt handlebar support	M 10	40 Nm (30 ft.lb)
Shock absorber top	M 12	60 Nm (44 ft.lb)
Shock absorber bottom	M 12	60 Nm (44 ft.lb)
Screw adjusting ring spring preload	M 6	8 Nm (6 ft.lb)
Other bolts on chassis	M 6	10 Nm (7 ft.lb)
	M 8	25 Nm (19 ft.lb)
	M 10	45 Nm (33 ft.lb)

# TECHNICAL DATA - ENGINE 125 / 200 2001

	125 SX	125 EXC	200 MXC	200 EXC
Engine				
Design	Liquid-cooled single-cylinder two-stroke engine with intake and exhaust control			
Piston displacement	124.8 ccm			
Bore / stroke	54 / 54.5 mm (2.126 / 2.145 in)			
Fuel	unleaded SUPER fuel, research octane no 95, mixed with high grade two stroke oil			
Oil / gasoline ratio	1:40-1:60 when using high grade two stroke oil (Shell Advance Racing X). When in doubt, please contact your importer			
Crankshaft bearing	1 deep-groove ball bearing / 1 cylinder roller bearing			
Connecting rod bearing	needle bearing			
Piston pin bearing	needle bearing			
Piston	cast piston			
Piston ring	one plain compression ring			
Dimension "X" <small>(upper edge piston-upper edge cylinder)</small>	0.0 mm (0.0 in)			
Ignition timing	1.4 mm (0.055 in) (16.5°) BTDC			
Spark plug	NGK BR9 EVX			
Electrode gap	0.60 mm (0,024 in)			
Dimension "Z" <small>height of the control flap</small>	42,5 mm (1.67 in)			
Primary drive	straight cut spur gears, primary ratio 23:73			
Clutch	multiple disc clutch in oil bath, hydraulic operated (Shell HF-E15)			
Transmission	6 speed, claw actuated			
Gear ratio				
1st gear	13 : 32 „1S32“	12 : 33 „1G33“	13 : 32 „1S32“	12 : 33 „1G33“
2nd gear	„2S15“ 15 : 30 „2S30“	„2S15“ 15 : 31 „2G31“	„2S15“ 15 : 30 „2S30“	„2S15“ 15 : 31 „2G31“
3rd gear	„3S17“ 17 : 28 „3S28“	„3S17“ 17 : 28 „3S28“	„3S17“ 17 : 28 „3S28“	„3S17“ 17 : 28 „3S28“
4th gear	„4S19“ 19 : 26 „4S26“	„4S19“ 19 : 26 „4S26“	„4S19“ 19 : 26 „4S26“	„4S19“ 19 : 26 „4S26“
5th gear	„5S21“ 21 : 25 „5S25“	„5S21“ 21 : 25 „5S25“	„5S21“ 21 : 25 „5S25“	„5S21“ 21 : 25 „5S25“
6th gear	„6S22“ 22 : 24 „6S24“	„6G20“ 20 : 20 „6G20“	„6S22“ 22 : 23 „6S23“	„6G22“ 22 : 20 „6G20“
Gear lubrication	0.7 l engine oil 20W-40 (Shell Advance VSX4)	0.7 l gear oil 80W (Shell Gear EP 80)	0.7 l engine oil 20W-40 (Shell Advance VSX4)	0.7 l gear oil 80W (Shell Gear EP 80)
Available chain sprockets	13t / 14t / 15t for chain 3/8 x 1/4"			
Coolant	1.2 litres, 40% anti freeze, 60% water, at least -25 °C (-13 °F)			
Ignition system	KOKUSAN 2K-1	KOKUSAN 2K-3	-	KOKUSAN 2K-3
Generator output	no generator	12V / 110 W	-	12V 110 W
Ignition system USA	KOKUSAN 2K-1		KOKUSAN 2K-2	
Generator output	no generator		12V 40 W	
Carburetor	flat-slide carburetor, carburetor setting see table			
Air-filter	wet foam type air filter insert			
Lubrication	<b>200 EXC Separate lubrication</b> Separate lubrication			
Engine oil	Shell Advance Ultra 2 or 2-stroke engine oil for a mixture ratio 1:50 and for separate lubrication			
Oil tank	1,3 liter (0,34 US Gallons)			

**TIGHTENING TORQUES - ENGINE**

Flange bolts - cylinder-head	M 7	18 Nm (13 ft.lb)
Nuts-cylinder base	M 8	30 Nm (22 ft.lb)
Flywheel collar nut	M 12x1	60 Nm (44 ft.lb)
Nut for primary sprocket (LH thread)	M 16x1.5	180 Nm (133 ft.lb)
Nut for inner clutch hub	M 18x1.5	120 Nm (88 ft.lb)
Crankcase and clutch cover bolts	M 6	8 Nm (6 ft.lb)
Spark plug	M 14x1.25	20 Nm (14 ft.lb)
Other bolts	M 6	10 Nm (7 ft.lb)
	M 8	25 Nm (19 ft.lb)
	M 10	45 Nm (33 ft.lb)

**TOLERANCES AND FITTING CLEARANCES**

Piston fitting clearance	125 = 0.06 mm 200 = 0.085 mm
Piston ring end cap	max. 0.40 mm
Connecting rod bearing - radial clearance	0.025–0.035 mm
Transmission shafts end float	0.20–0.40 mm
Clutch springs - length	new = 39 mm, minimum length = 38 mm

**GASKET THICKNESSES**

Crankcase	0,5 mm
Clutch cover	0,5 mm
Clutch driving cylinder	0.30 / 0.50 / 0.75 mm
Cylinder bottom gasket	as required
Available bottom gasket	0.07 / 0.15 / 0.20 / 0.25 / 0.40 / 0.50 / 0.75 mm
Cylinder-head gasket	1.10 mm + O-ring

**BASIC CARBURETOR SETTING**

	125 SX	125 EXC USA 200 MXC/EXC USA	200 EXC AUS 200 EXC SGP	125 EXC EU	200 EXC EU
Carburetor	Keihin PWK 39	Keihin PWK 38 AG	Keihin PWK 38 AG	Keihin PWK 38 AG	Keihin PWK 38 AG
Carburetor setting number	250200	270200	280200	260200	290200
Main jet	185 (182/188)	180 (185)	180 (185)	148 (180/185)	180 (185)
Idling jet	48 (45/50)	45 (48)	45 (48)	35 (45/48)	35 (45/48)
Starting jet	85	85	85	85	85
Jetneedle	R 1469 D (R 1470 D)	NOZ G (NOZ H)	NOZ G (NOZ H)	R 1472 N (NOZ G/NOZ H)	R 1475 J (NOZ G/NOZ H)
Needle position from top	III	III	III	IV	III
Throttle valve	55	6.5	6.5	6.5	6.5
Air adjustment screw open	1,5	1,5	1,5	1,5	1,5
Performance restrictor	–	–	slide stop 36mm	–	slide stop 36mm

**TECHNICAL SPECIFICATIONS CHASSIS 125 SX / EXC, 200 MXC / EXC 2001**

	125 SX	125 EXC	200 MXC	200 EXC
Frame	Central chrome-moly-steel frame			
Fork	White Power – Up Side Down 43 MA			
Wheel travel front/rear	295/320 mm (11,3/12,6 in)			
Rear suspension	WP Progressive Damping System shock absorber, aluminium swingarm			
Front brake	Disc brake with carbon-steel brake disc Ø 260 mm (10.2 in), brake caliper floated			
Rear brake	Disc brake with carbon-steel brake disc Ø 220 mm (8.7 in), brake caliper floated			
Brake discs	Wear limit max. 0,4 mm (0,016 in)			
Front tires	80/100 - 21" 51M	90/90 - 21" 54R	–	90/90 - 21" 54R
Front tires USA	80/100 - 21" 51M	80/100 - 21" 51M	80/100 - 21" 51M	80/100 - 21" 51M
Air pressure offroad	1,0 bar (14psi)	1,0 bar (14psi)	1,0 bar (14psi)	1,0 bar (14psi)
Air pressure road driver only	–	1,5 bar (21psi)	–	1,5 bar (21psi)
Rear tires	100/90 - 19" 57M	120/90 - 18" 65R	–	120/90 - 18" 65R
Rear tires USA	100/90 - 19" 57M	100/100 - 18" 59M	100/100 - 18" 59M	100/100 - 18" 59M
Air pressure offroad	1,0 bar (14psi)	1,0 bar (14psi)	1,0 bar (14psi)	1,0 bar (14psi)
Air pressure road driver only	–	2,0 bar (28psi)	–	2,0 bar (28psi)
Fuel tank capacity	7,5 liter (2 US Gal)	8,5 liter (2,2 US Gal)	11 liter (2,9 US Gal)	8,5/11 liter (2,2/2,9 US Gal)
Final drive ratio	13:50t	14:38t	–	14:42t / 14:48t
Final drive ratio USA	13:50t	13:50t	14:48t	14:48t
Chain	5/8 x 1/4 "			
Available final sprockets	38t, 40t, 42t, 45t, 48t, 50t, 52t			
Steering head angle	63°			
Wheel base	1461 ± 10 mm (57,3 ± 0,4 in)			
Seat height, unloaded	925 mm (36,5 in)			
Ground clearance, unloaded	385 mm (15,2 in)			
Dead-weight *	92 kg (203 lbs)	100 kg (221 lbs)	–	101 kg (223 lbs)

\* Dead-weight without fuel

**STANDARD ADJUSTMENT - FORK**

	WP 0518V701	WP 0518V702
Compression adjuster	16	16
Rebound adjuster	16	12
Spring	3,8 N/mm	3,8 N/mm
Spring preload	5 mm (0.2 in)	5 mm (0.2 in)
Air chamber length	130 mm (5.1 in)	150 mm (5.9 in)
Fork oil	SAE 5	SAE 5

**TIGHTENING TORQUES - CHASSIS**

Collar nut front wheel spindle	M 16x1,5	40 Nm (30 ft.lb)
Brake caliper front	M 8	25 Nm (19 ft.lb) + Loctite 243
Clamping bolts upper fork bridge	M 8	20 Nm (15 ft.lb)
Clamping bolts lower fork bridge	M 8	15 Nm (11 ft.lb)
Clamping bolts fork stubs	M8	10 Nm (7 ft.lb)
Collar nut rear wheel spindle	M 20x1,5	80 Nm (59 ft.lb)
Hexagon nut swing arm bolt	M 14x1,5	100 Nm (74 ft.lb)
Collar bolt handlebar clamp	M 8	20 Nm (15 ft.lb)
Allen head bolt handlebar support	M 10	40 Nm (30 ft.lb) + Loctite 243
Shock absorber top	M 12	60 Nm (44 ft.lb)
Shock absorber bottom	M 12	60 Nm (44 ft.lb)
Screw adjusting ring spring preload	M 6	8 Nm (6 ft.lb)
Other bolts on chassis	M 6 M 8 M 10	10 Nm (7 ft.lb) 25 Nm (19 ft.lb) 45 Nm (33 ft.lb)

**STANDARD ADJUSTMENT - SHOCK ABSORBER**

	WP 1218V728	WP 1218V729
Compression adjuster	5	5
Rebound adjuster	25	23
Spring	PDS2-250	PDS1-250
Spring preload	5 mm (0.2 in)	6 mm (0.2 in)



**TECHNICAL DATA - ENGINE 125 / 200 2002**

Engine	125 SX	125 EXC	200 MXC	200 EXC
Design	Liquid-cooled single-cylinder two-stroke engine with intake and exhaust control			
Piston displacement	124.8 ccm			
Bore / stroke	54 / 54,5 mm (2.126 / 2.145 in)			
Fuel	unleaded SUPER fuel, research octane no 95, mixed with high grade two stroke oil			
Oil / gasolin ratio	1:40-1:60 when using high grade two stroke oil (Shell Advance Racing X). When in doubt, please contact your importer			
Crankshaft bearing	1 deep-groove ball bearing / 1 cylinder roller bearing			
Connecting rod bearing	needle bearing			
Piston pin bearing	needle bearing			
Piston	cast piston			
Piston ring	one plain compression ring			
Dimension "X" <small>(upper edge piston- upper edge cylinder)</small>	0.0 mm (0.0 in)			
Ignition timing	1.4 mm (0.055 in) (16.5°) BTDC			
Spark plug	NGK BR9 EVX			
Electrode gap	0.60 mm (0,024 in)			
Dimension "Z" <small>height of the control flap</small>	43 mm (1.67 in)			
Primary drive	straight cut spur gears, primary ratio 23:73			
Clutch	multiple disc clutch in oil bath, hydraulic operated (Shell HF-E15)			
Transmission	6 speed, claw actuated			
Gear ratio				
1st gear	13 : 32 „1S32“	12 : 33 „1G33“	13 : 32 „1S32“	12 : 33 „1G33“
2nd gear	„2S15“ 15 : 30 „2S30“	„2S15“ 15 : 31 „2G31“	„2S15“ 15 : 30 „2S30“	„2S15“ 15 : 31 „2G31“
3rd gear	„3S17“ 17 : 28 „3S28“	„3S17“ 17 : 28 „3S28“	„3S17“ 17 : 28 „3S28“	„3S17“ 17 : 28 „3S28“
4th gear	„4S19“ 19 : 26 „4S26“	„4S19“ 19 : 26 „4S26“	„4S19“ 19 : 26 „4S26“	„4S19“ 19 : 26 „4S26“
5th gear	„5S21“ 21 : 25 „5S25“	„5S21“ 21 : 25 „5S25“	„5S21“ 21 : 25 „5S25“	„5G17“ 21 : 25 „5G19“
6th gear	„6S22“ 22 : 24 „6S24“	„6G20“ 20 : 20 „6G20“	„6S22“ 20 : 23 „6S23“	„6G22“ 20 : 20 „6G20“
Gear lubrication	0.7 l engine oil 20W-40 (Shell Advance VSX4)	0.7 l gear oil 80W (Shell Gear EP 80)	0.7 l engine oil 20W-40 (Shell Advance VSX4)	0.7 l gear oil 80W (Shell Gear EP 80)
Available chain sprockets	13t / 14t / 15t for chain $\frac{5}{8} \times \frac{1}{4}$ "			
Coolant	1.2 litres, 40% anti freeze, 60% water, at least -25 °C (-13 °F)			
Ignition system	KOKUSAN 2K-3			
Generator output	no generator	12V / 110 W	-	KOKUSAN 2K-3 12V 110 W
Ignition system USA	KOKUSAN 2K-1			
Generator output	no generator	12V / 110 W	KOKUSAN 2K-2 12V 40 W	
Carburetor	flat-slide carburetor, carburetor setting see table			
Air-filter	wet foam type air filter insert			
Lubrication	<b>200 EXC SEPARATE LUBRICATION</b>			
Engine oil	Separate lubrication			
Oil tank	Shell Advance Ultra 2 or 2-stroke engine oil for a mixture ratio 1:50 and for separate lubrication 1,3 liter (0,34 US Gallons)			

TIGHTENING TORQUES - ENGINE			
Flange bolts - cylinder-head	M 7	18 Nm	(13 ft.lb)
Nuts-cylinder base	M 8	30 Nm	(22 ft.lb)
Flywheel collar nut	M 12x1	60 Nm	(44 ft.lb)
Nut for primary sprocket (LH thread)	M 16x1.5	180 Nm	(133 ft.lb)
Nut for inner clutch hub	M 18x1.5	120 Nm	(88 ft.lb)
Crankcase and clutch cover bolts	M 6	8 Nm	(6 ft.lb)
Spark plug	M 14x1.25	20 Nm	(14 ft.lb)
Other bolts	M 6	10 Nm	(7 ft.lb)
	M 8	25 Nm	(19 ft.lb)
	M 10	45 Nm	(33 ft.lb)

TOLERANCES AND FITTING CLEARANCES	
Piston fitting clearance	125 = 0.06 mm 200 = 0.055 mm
Piston ring end cap	max. 0.40 mm
Connecting rod bearing - radial clearance	0.025–0.035 mm
Transmission shafts end float	0.20–0.40 mm
Clutch springs - length	new = 39 mm, minimum length = 38 mm

GASKET THICKNESSES	
Crankcase	0,5 mm
Clutch cover	0,5 mm
Clutch driving cylinder	0.30 / 0.50 / 0.75 mm
Cylinder bottom gasket	as required
Available bottom gasket	0.07 / 0.15 / 0.20 / 0.25 / 0.40 / 0.50 / 0.75 mm
Cylinder-head gasket	125 =shapedring + O-ring 200=1.10 mm + O-ring

BASIC CARBURETOR SETTING				
	125 SX	200 MXC/EXC USA	200 EXC AUS 200 EXC SGP 200 EXC EU	125 EXC EU 125 EXC AUS
Carburetor	Keihin PWK 39	Keihin PWK 38 AG	Keihin PWK 38 AG	Keihin PWK 38 AG
Carburetor setting number	020201	010201	051200	041200
Main jet	185 (182/188/190)	178 (180/185)	180 (178)	148 (180/185)
Idling jet	48 (45/50)	45 (48)	35 (45/48)	35 (45/48)
Starting jet	85	85	85	85
Jetneedle	R 1469 D (R 1470 D)	NOZ F (NOZ G)	R 1475J (NOZ G/NOZ F)	R 1472 N (NOZ G/NOZ F)
Needle position from top	III	III	III	V
Throttle valve	5.5 (6)	6.5	6.5	6.5
Air adjustment screw open	1,5	1,5	1,5	1,5
Performance restrictor	–	–	slide stop 36mm	–

# TECHNICAL SPECIFICATIONS CHASSIS 125 SX / EXC, 200 MXC / EXC 2002

	125 SX	125 EXC	200 MXC	200 EXC
Frame	Central chrome-moly-steel frame			
Fork	<b>WP – USD 48 MA</b>	<b>White Power – Up Side Down 43 MA</b>		
Wheel travel front/rear	295/320 mm (11,3/12,6 in)			
Rear suspension	WP PDS 5018 (Progressive Damping System) shock absorber, aluminium swingarm			
Front brake	Disc brake with carbon-steel brake disc Ø 260 mm (10.2 in), brake caliper floated			
Rear brake	Disc brake with carbon-steel brake disc Ø 220 mm (8.7 in), brake caliper floated			
Brake discs	Wear limit max. 0,4 mm (0,016 in)			
Front tires	80/100 - 21" 51M	90/90 - 21" 54R	–	90/90 - 21" 54R
Front tires USA	80/100 - 21" 51M	80/100 - 21" 51M	80/100 - 21" 51M	80/100 - 21" 51M
Air pressure offroad	1,0 bar (14psi)	1,0 bar (14psi)	1,0 bar (14psi)	1,0 bar (14psi)
Air pressure road driver only	–	1,5 bar (21psi)	–	1,5 bar (21psi)
Rear tires	100/90 - 19" 57M	120/90 - 18" 65R	–	120/90 - 18" 65R
Rear tires USA	100/90 - 19" 57M	100/100 - 18" 59M	100/100 - 18" 59M	100/100 - 18" 59M
Air pressure offroad	1,0 bar (14psi)	1,0 bar (14psi)	1,0 bar (14psi)	1,0 bar (14psi)
Air pressure road driver only	–	2,0 bar (28psi)	–	2,0 bar (28psi)
Fuel tank capacity	7,5 liter (2 US Gal)	8,5 liter (2,2 US Gal)	11 liter (2,9 US Gal)	8,5/11 liter (2,2/2,9 US Gal)
Final drive ratio	13:50t	14:38t	–	14:45t / 14:48t
Final drive ratio USA	13:50t	13:50t	14:48t	14:48t
Chain	5/8 x 1/4 "			
Available final sprockets	38t, 40t, 42t, 45t, 48t, 50t, 52t			
Bulps	headlight	HS1 12V 35/35W		
	parking light	12V 5W (Socket W2, 1x9,5d)		
	instrument light	12V 1,2W (Socket W2, 1x4,6d)		
	brake- rear light	12V 21/5W (Socket BaY15d)		
	flasher light	12V 10W (Socket Ba15s)		
	license plate illumination	12V 1,2W (Socket 1x4,6d)		
Steering head angle	63°			
Wheel base	1461 ± 10 mm (57,3 ± 0,4 in)			
Seat height, unloaded	925 mm (36,5 in)			
Ground clearance, unloaded	385 mm (15,2 in)			
Dead-weight *	92 kg (203 lbs)	100 kg (221 lbs)	–	101 kg (223 lbs)
Dead-weight USA *	92 kg (203 lbs)	96 kg (212 lbs)	96 kg (212 lbs)	97 kg (214 lbs)

\* Dead-weight without fuel

### STANDARD ADJUSTMENT - FORK

	WP 4860 MXMA 1418W708	WP 4357 MXMA 0518W710
Compression adjuster	20	20
Rebound adjuster	16	12
Spring	4,0 N/mm	3,8 N/mm
Spring preload	5 mm (0.2in)	5 mm (0.2in)
Air chamber length	100 mm (5.1in)	140 mm (5.9in)
Fork oil	SAE 5	SAE 5

### STANDARD ADJUSTMENT - SHOCK ABSORBER

	WP 5018 PDS-DCC 1218W734	WP 5018 PDS-MCC 1218W735
Compression adjuster	15 LS (low speed) 2 HS (high speed)	15
Rebound adjuster	25	25
Spring	PDS6–260	PDS5–260
Spring preload	4 mm (0.2 in)	5 mm (0.2 in)

### TIGHTENING TORQUES - CHASSIS

Collar nut front wheel spindle	M 16/20x1,5	40 Nm (30 ft.lb)
Brake caliper front	M 8	25 Nm (19 ft.lb) + Loctite 243
Clamping bolts upper fork bridge	M 8	20 Nm (15 ft.lb)
Clamping bolts lower fork bridge	M 8	15 Nm (11 ft.lb)
Clamping bolts fork stubs	M8	10 Nm (7 ft.lb)
Collar nut rear wheel spindle	M 20x1.5	80 Nm (59 ft.lb)
Hexagon nut swing arm bolt	M 14x1.5	100 Nm (74 ft.lb)
Collar bolt handlebar clamp	M 8	20 Nm (15 ft.lb)
Allen head bolt handlebar support	M 10	40 Nm (30 ft.lb) + Loctite 243
Shock absorber top	M 12	60 Nm (44 ft.lb)
Shock absorber bottom	M 12	60 Nm (44 ft.lb)
Screw adjusting ring spring preload	M 6	8 Nm (6 ft.lb)
Other bolts on chassis	M 6 M 8 M 10	10 Nm (7 ft.lb) 25 Nm (19 ft.lb) 45 Nm (33 ft.lb)

# TECHNICAL DATA - ENGINE 125 / 200 2003

	125 SX	125 EXC	200 SX	200 MXC	200 EXC
Engine					
Design	Liquid-cooled, single-cylinder, two-stroke engine with intake and exhaust control				
Piston displacement	124.8 ccm				
Bore / stroke	54 / 54.5 mm (2.126 / 2.145 in)				
Fuel	unleaded SUPER fuel, research octane no 95, mixed with high grade, two- stroke oil				
Oil / gasoline ratio	1:40-1:60 when using high grade, two- stroke oil (Shell Advance Racing X). When in doubt, please contact your importer				
Crankshaft bearing	1 deep-groove ball bearing / 1 cylinder roller bearing				
Connecting rod bearing	needle bearing				
Piston pin bearing	needle bearing				
Piston	cast piston				
Piston ring	one plain compression ring	two plain compression rings	one plain compression ring	two plain compression rings	two plain compression rings
Dimension "X" (upper edge piston-upper edge cylinder)	0,0 mm				
Ignition timing	1.4 mm (0.055 in) (16.5°) BTDC				
Spark plug	NGK BR9 EVX				
Electrode gap	0,60 mm				
Dimension "Z" (height of the control flap)	43 mm (1.67 in)				
Primary drive	straight cut-spur gears, primary ratio 23:73				
Clutch	multiple disc clutch in oil bath, hydraulically operated (Shell HF-E15)				
Transmission	5 speed, claw actuated				
Gear ratio	6 speed, claw actuated				
1st gear	13 : 32 „1S32"	12 : 33 „1G33"	13 : 32 „1S32"	13 : 32 „1S32"	13 : 33 „1G33"
2nd gear	„2S15" 15 : 30 „2S30"	„2S15" 15 : 31 „2G31"	„2S15" 15 : 30 „2S30"	„2S15" 15 : 30 „2S30"	„2S15" 15 : 31 „2G31"
3rd gear	„3S17" 17 : 28 „3S28"	„3S17" 17 : 28 „3S28"	„3S17" 17 : 28 „3S28"	„3S17" 17 : 28 „3S28"	„3S17" 17 : 28 „3S28"
4th gear	„4S19" 19 : 26 „4S26"	„4S19" 19 : 26 „4S26"	„4S19" 19 : 26 „4S26"	„4S19" 19 : 26 „4S26"	„4S19" 19 : 26 „4S26"
5th gear	„5S21" 21 : 25 „5S25"	„5S21" 21 : 25 „5S25"	„5S21" 21 : 25 „5S25"	„5S21" 21 : 25 „5S25"	„5G17" 17 : 19 „5G19"
6th gear	„6G20" 20 : 20 „6G20"	„6G20" 20 : 20 „6G20"	„6S22" 22 : 23 „6S23"	„6S22" 22 : 23 „6S23"	„6G22" 22 : 20 „6G20"
Gear lubrication	0.7 l engine oil 20W-40 (Shell Advance VSX4)	0.7 l gear oil 80W (Shell Gear EP 80)	0.7 l engine oil 20W-40 (Shell Advance VSX4)	0.7 l gear oil 80W (Shell Gear EP 80)	0.7 l gear oil 80W (Shell Gear EP 80)
Available chain sprockets	13Z / 14Z / 15Z for chain 7/8 x 1/4"				
Coolant	1.2 litres, 40% anti freeze, 60% water, at least -25 °C (-13 °F)				
Ignition system	KOKUSAN 2K-1	KOKUSAN 2K-3	KOKUSAN 2K-1	-	KOKUSAN 2K-3
Generator output	no generator	12V / 110 W	no generator	-	12V 110 W
Ignition system USA	KOKUSAN 2K-1	KOKUSAN 2K-2	KOKUSAN 2K-1	KOKUSAN 2K-1	KOKUSAN 2K-2
Generator output	no generator	12V 40 W	no generator	no generator	12V 40 W
Carburetor	flat-slide carburetor, carburetor setting see table				
Air-filter	wet foam type air filter insert				

TIGHTENING TORQUES - ENGINE		
Flange bolts - cylinder-head	M 7	18 Nm
Nuts-cylinder base	M 8	30 Nm
Flywheel collar nut	M 12x1	60 Nm
Nut for primary sprocket (LH thread)	M 16x1.5	180 Nm
Nut for inner clutch hub	M 18x1.5	120 Nm
Crankcase and clutch cover bolts	M 6	8 Nm
Spark plug	M 14x1.25	20 Nm
Swingarm pivot	M 14x1.5	100 Nm
Other bolts	M 6	10 Nm
	M 8	25 Nm
	M 10	45 Nm

BASIC CARBURETOR SETTING			
	200 EXC AUS 200 EXC EU	200 MXC/EXC USA	200 SX
Carburetor	Keihin PWK 38 AG	Keihin PWK 38 AG	Keihin PWK 39
Carburetor setting number	100202	080202	090202
Main jet	180 (178)	178(180/185)	190 (188,192)
Idling jet	35 (45/48)	45 (48)	48 (45)
Starting jet	85	85	85
Jet needle	R 1475J (NOZ E/NOZ F)	NOZ E (NOZ F)	R 1468G (R1469G)
Needle position from top	III	III	III
Throttle valve	6.5	6.5	5.5
Air adjustment screw open	1,5	1,5	1,5
Performance restrictor	slide stop 36mm	-	-

BASIC CARBURETOR SETTING			
	125 EXC EU 125 EXC AUS	125 EXC SIX DAYS	125 SX
Carburetor	Keihin PWK 38 AG	Keihin PWK 38 AG	Keihin PWK 39
Carburetor setting number	070202	160202	060202
Main jet	148 (180/185)	180(185)	185 (188/190)
Idling jet	35 (45/48)	45 (48)	48 (45)
Starting jet	85	85	85
Jet needle	R 1472 N (NOZ E/NOZ F)	NOZ E (NOZ F)	R 1469 D (R 1470 D)
Needle position from top	V	IIII	III
Throttle valve	6.5	6.5	5.5 (6)
Air adjustment screw open	1,5	1,5	1,5
Performance restrictor	-	-	-

TOLERANCES AND FITTING CLEARANCES	
Piston fitting clearance	125 = 0.06 mm 200 = 0.055 mm
Piston ring end cap	max. 0.40 mm
Connecting rod bearing - radial clearance	0.025–0.035 mm
Piston pin – radial clearance	0,030 mm
Transmission shafts end float	0.20–0.40 mm
Clutch springs - length	new = 39 mm, minimum length = 38 mm
Clutch discs	min. 2,9 mm (new 3,1 mm)
Crank stud - run out	0,02 mm
Crankshaft webs outer dimension	55 mm

GASKET THICKNESSES	
Crankcase	0,5 mm
Clutch cover	0,5 mm
Clutch driving cylinder	0.30 / 0.50 / 0.75 mm
Cylinder bottom gasket	as required
Available bottom gasket	0.07 / 0.15 / 0.20 / 0.25 / 0.40 / 0.50 / 0.75 mm

# TECHNICAL SPECIFICATIONS CHASSIS 125 SX / EXC, 200 SX / MXC / EXC 2003

	125 SX	125 EXC	200 SX	200 MXC	200 EXC
Frame	Central chrome-moly-steel frame				
Fork	White Power – Upside down 48 MA 300/335 mm (11.8/13.2 in)				
Wheel travel front/rear	300/335 mm (11.8/13.2 in)				
Rear suspension	WP PDS 5018 (Progressive Damping System) shock absorber, aluminium swingarm				
Front brake	Disc brake with carbon-steel brake disc Ø 260 mm (10.2 in), brake caliper floated				
Rear brake	Disc brake with carbon-steel brake disc Ø 220 mm (8.7 in), brake caliper floated				
Brake discs	Wear limit max. 0.4 mm (0.016 in)				
Front tires	80/100 - 21" 51M	90/90 - 21" 54R	80/100 - 21" 51M	–	90/90 - 21" 54R
Front tires USA	80/100 - 21" 51M	80/100 - 21" 51M	80/100 - 21" 51M	80/100 - 21" 51M	80/100 - 21" 51M
Air pressure offroad	1.0 bar (14psi)	1.0 bar (14psi)	1.0 bar (14psi)	1.0 bar (14psi)	1.0 bar (14psi)
Air pressure road driver only	–	1.5 bar (21psi)	–	–	1.5 bar (21psi)
Rear tires	100/90 - 19" 57M	120/90 - 18" 65R	100/90 - 19" 57M	–	120/90 - 18" 65R
Rear tires USA	100/90 - 19" 57M	100/100 - 18" 59M	100/90 - 19" 57M	100/100 - 18" 59M	100/100 - 18" 59M
Air pressure offroad	1.0 bar (14psi)	1.0 bar (14psi)	1.0 bar (14psi)	1.0 bar (14psi)	1.0 bar (14psi)
Air pressure road driver only	–	2.0 bar (28psi)	–	–	2.0 bar (28psi)
Fuel tank capacity	7.5 liters (2 US Gallons)	9 liters (2.3 US Gallons)	7.5 liters (2 US Gallons)	11 liters (2.9 US Gallons)	9/11 liter (2.3/2.9 US gallons)
Final drive ratio	13:50t	14:38t	14:48t	–	14:45t / 14:48t
Final drive ratio USA	13:50t	13:50t	14:48t	14:48t	14:48t
Chain	5/8 x 1/4"				
Available final sprockets	38t, 40t, 42t, 45t, 48t, 50t, 52t				
Bulbs	headlight HS1 12V 35/35W parking light 12V 5W (base W2, 1x9,5d) instrument light 12V 1,2W (base W2, 1x4,6d) brake- rear light 12V 21/5W (base BaY15d) flasher light 12V 10W (base Ba15s) license plate illumination 12V 1,2W (base 1x4,6d) 63°				
Steering head angle	63°				
Wheel base	1461 ± 10 mm (57,3 ± 0,4 in)				
Seat height, unloaded	925 mm (36,5 in)				
Ground clearance, unloaded	385 mm (15,2 in)				

STANDARD ADJUSTMENT - FORK		
	WP 4860 MXMA 1418X725	WP 4860 MXMA 1418X735
Compression adjuster	20	22
Rebound adjuster	20	20
Spring	4.0 N/mm	3.8 N/mm
Spring preload	5 mm (0.2in)	5 mm (0.2in)
Air chamber length	100 mm (5.1in)	110 mm (4,3in)
Fork oil	SAE 5	SAE 5

STANDARD ADJUSTMENT - SHOCK ABSORBER		
	WP 5018 PDS-DCC 1218X756	WP 5018 PDS-MCC 1218X757
Compression adjuster	17 LS (low speed) 2 HS (high speed)	17
Rebound adjuster	28	28
Spring	71-90/260	66-86/260
Spring preload	6 mm (0.2 in)	7 mm (0.2 in)

TIGHTENING TORQUES - CHASSIS		
Collar bolt, front wheel spindle	M 24x1,5	40 Nm
Brake caliper, front	M 8	Loctite 243 + 25 Nm
Brake disk, front	M 6 10.9	Loctite 243 + 15 Nm
Brake disk, rear	M 6	Loctite 243 + 15 Nm
Clamping bolts, upper fork bridge	M 8	20 Nm
Clamping bolts, lower fork bridge	M 8	15 Nm
Clamping bolts, fork stubs	M 8	10 Nm
Collar nut, rear wheel spindle	M 20x1,5	80 Nm
Hexagon nut, swing arm bolt	M 14x1,5	100 Nm
Hexagon collar bolt, handlebar clamp	M 8	20 Nm
Allan head bolt, handlebar support	M 10	Loctite 243 + 40 Nm
Shock absorber, top	M 12	60 Nm
Shock absorber, bottom	M 12	60 Nm
Sprocket bolts	M 8	Loctite 243 + 35 Nm
Ball joint for push rod	M 6	Loctite 243 + 10 Nm
Engine mounting bolt	M 10	45 Nm
Engine brace	M 8	33 Nm
Screw adjusting ring spring preload shock abs.	M6	8 Nm
Spoke nipple	M4,5 /M5	5 Nm
Other bolts on chassis	M 6	10 Nm
	M 8	25 Nm
	M 10	45 Nm
Other collar nuts on chassis	M 6	15 Nm
	M 8	30 Nm
	M 10	50 Nm

# TECHNICAL DATA – ENGINE 125 / 200 SX, EXC 2004

	125 SX	125 EXC	200 SX	200 EXC
Engine				
Design	Liquid-cooled, single-cylinder, two-stroke engine with intake and exhaust control			
Piston displacement	124.8 ccm			
Bore / stroke	54 / 54.5 mm (2.126 / 2.145 in)			
Fuel	unleaded fuel with at least RON 95 (USA = Premium RON 91), mixed with high grade two stroke oil			
Oil / gasoline ratio	1:40-1:60 when using high grade, two- stroke oil (Motorex Cross Power 2T). When in doubt, please contact your importer			
Crankshaft bearing	1 deep-groove ball bearing / 1 cylinder roller bearing			
Connecting rod bearing	needle bearing			
Piston pin bearing	needle bearing			
Piston	cast piston			
Piston ring	one plain compression ring	two plain compression rings	one plain compression ring	two plain compression rings
Dimension "X" <small>(upper edge piston- upper edge cylinder)</small>	0,0 mm			
Ignition timing	1.4 mm (0.055 in) (16.5°) BTDC			
Spark plug	NGK BR9 EVX			
Electrode gap	0,60 mm			
Dimension "Z" <small>(height of the control flap)</small>	43 mm (1.67 in)			
Primary drive	straight cut spur gears, primary ratio 23:73			
Clutch	multiple disc clutch in oil bath, hydraulically operated (Motorex Kupplungs-Fluid 75)			
Transmission	5 speed, claw actuated			
Gear ratio	13 : 32 „1S32“	12 : 33 „1G33“	13 : 32 „1S32“	13 : 33 „1G33“
1st gear	„2S15“ 15 : 30 „2S30“	„2S15“ 15 : 31 „2G31“	„2S15“ 15 : 30 „2S30“	„2S15“ 15 : 31 „2G31“
2nd gear	„3S17“ 17 : 28 „3S28“	„3S17“ 17 : 28 „3S28“	„3S17“ 17 : 28 „3S28“	„3S17“ 17 : 28 „3S28“
3rd gear	„4S19“ 19 : 26 „4S26“	„4S19“ 19 : 26 „4S26“	„4S19“ 19 : 26 „4S26“	„4S19“ 19 : 26 „4S26“
4th gear	„5S21“ 21 : 25 „5S25“	„5S21“ 21 : 25 „5S25“	„5S21“ 21 : 25 „5S25“	„5G17“ 21 : 25 „5G19“
5th gear	„6G20“ 20 : 20 „6G20“	„6G20“ 20 : 20 „6G20“	„6S22“ 20 : 23 „6S23“	„6G22“ 20 : 20 „6G20“
6th gear				
Gear lubrication	0.7 l engine oil (Motorex Top Speed 4T 15W50)			
Available chain sprockets	13Z / 14Z / 15Z for chain $\frac{3}{8}$ x $\frac{1}{4}$ "			
Coolant	1.2 litres, 40% anti freeze, 60% water, at least -25 °C (-13 °F)			
Ignition system	KOKUSAN 2K-1	KOKUSAN 2K-3	KOKUSAN 2K-3	KOKUSAN 2K-3
Generator output	no generator	12V / 110 W	12V / 110 W	12V 110 W
Ignition system USA	KOKUSAN 2K-1	KOKUSAN 2K-2	KOKUSAN 2K-3	KOKUSAN 2K-2
Generator output	no generator	12V 40 W	12V / 110 W	12V 40 W
Carburetor	flat-slide carburetor, carburetor setting see table			
Air-filter	wet foam type air filter insert			



TIGHTENING TORQUES - ENGINE		
Flange bolts - cylinder-head	M 7	18 Nm
Nuts-cylinder base	M 8	30 Nm
Flywheel collar nut	M 12x1	60 Nm
Nut for primary sprocket (LH thread)	M 16x1.5	180 Nm
Nut for inner clutch hub	M 18x1.5	120 Nm
Crankcase and clutch cover bolts	M 6	8 Nm
Spark plug	M 14x1.25	20 Nm
Swingarm pivot	M 16x1.5	100 Nm
Other bolts	M 6	10 Nm
	M 8	25 Nm
	M 10	45 Nm

BASIC CARBURETOR SETTING			
	125 SX	125 EXC EU 125 EXC AUS	125 EXC EU/AUS not restricted
Carburetor	Keihin PWK 39	Keihin PWK 38 AG	Keihin PWK 38 AG
Carburetor setting number	141102	070202	-
Main jet	188 (185/190)	148 (180/185)	180
Idling jet	45 (48)	35 (45/48)	45
Starting jet	85	85	85
Jet needle	R 1469 D (R 1468 D)	R 1472 N (NOZ E/NOZ F)	NOZ E
Needle position from top	II	V	IV
Throttle valve	5.5	6.5	6.5
Air adjustment screw open	1,5	1,5	1,5
Performance restrictor	-	-	-

BASIC CARBURETOR SETTING				
	200 SX	200 EXC USA	200 EXC EU 200 EXC AUS	200 EXC EU/AUS not restricted
Carburetor	Keihin PWK 39	Keihin PWK 38 AG	Keihin PWK 38 AG	Keihin PWK 38 AG
Carburetor setting number	151102	080202	100202	-
Main jet	188 (185/190)	178(180/185)	180 (178)	178
Idling jet	45 (48)	45 (48)	35 (45/48)	45
Starting jet	85	85	85	85
Jet needle	R 1468G (R1469G)	NOZ E (NOZ F)	R 1475J (NOZ E/NOZ F)	NOZ E
Needle position from top	III	III	III	III
Throttle valve	5.5	6.5	6.5	6.5
Air adjustment screw open	1,5	1,5	1,5	1,5
Performance restrictor	-	-	Slide stop 36mm	-

# TECHNICAL SPECIFICATIONS – CHASSIS 125 / 200 SX, EXC 2004

	125 SX	125 EXC	200 SX	200 EXC
Frame	Central chrome-moly-steel frame			
Fork	White Power – Upside down 48 MA 300/335 mm (11.8/13.2 in)			
Wheel travel front/rear	WP PDS 5018 (Progressive Damping System) shock absorber, aluminium swingarm			
Rear suspension	Disc brake with carbon-steel brake disc Ø 260 mm (10.2 in), brake caliper floated			
Front brake	Disc brake with carbon-steel brake disc Ø 220 mm (8.7 in), brake caliper floated			
Rear brake	Wear limit max. 0.4 mm (0.016 in)			
Brake discs	90/90 - 21" MT83			
Front tires	80/100 - 21" 51M, M59	90/90 - 21" MT83	80/100 - 21" 51M, M59	90/90 - 21" MT83
Front tires USA	80/100 - 21" 51M, M59	–	80/100 - 21" 51M, M59	80/100 - 21" 51M, 59
Air pressure offroad	1.0 bar (14psi)	1.0 bar (14psi)	1.0 bar (14psi)	1.0 bar (14psi)
Air pressure road driver only	–	1.5 bar (21psi)	–	1.5 bar (21psi)
Rear tires	100/90 - 19" 57M, M70	120/90 - 18" MT 83	100/90 - 19" 57M, M70	120/90 - 18" MT83
Rear tires USA	100/90 - 19" 57M, M70	–	100/90 - 19" 57M, M70	100/100 - 18" 59M, M402
Air pressure offroad	1.0 bar (14psi)	1.0 bar (14psi)	1.0 bar (14psi)	1.0 bar (14psi)
Air pressure road driver only	–	2.0 bar (28psi)	–	2.0 bar (28psi)
Fuel tank capacity	7.5 liters (2 US Gallons)	9 liters (2.3 US Gallons)	7.5 liters (2 US Gallons)	9/11 liter (2.3/2.9 US gallons)
Final drive ratio	13:50t	14:38t	14:48t	14:45t / 14:48t
Final drive ratio USA	13:50t	13:50t	14:48t	14:48t
Chain	5/8 x 1/4"			
Available final sprockets	38t, 40t, 42t, 45t, 48t, 50t, 52t			
Bulbs	headlight HS1 12V 35/35W parking light 12V 5W (base W2, 1x9,5d) instrument light 12V 1,2W (base W2, 1x4,6d) brake- rear light 12V 21/5W (base BaY15d) flasher light 12V 10W (base Ba15s) license plate illumination 12V 1,2W (base 1x4,6d)			
Steering head angle	63°			
Wheel base	1461 ± 10 mm (57,3 ± 0.4 in)			
Seat height, unloaded	925 mm (36,5 in)			
Ground clearance, unloaded	390 mm (15,3 in)			

STANDARD ADJUSTMENT - FORK		
	125/200 SX	125/200 EXC
	WP 4860 MXMA 1418Y743	WP 4860 MXMA 1418Y744
Compression adjuster	18	20
Rebound adjuster	18	20
Spring	4,2 N/mm	3,8 N/mm
Spring preload	6 mm	5 mm
Air chamber length	90 mm	120 mm
Fork oil	SAE 5	SAE 5

STANDARD ADJUSTMENT - SHOCK ABSORBER		
	125/200 SX	125/200 EXC
	WP 5018 PDS-DCC 1218Y767	WP 5018 PDS-MCC 1218Y768
Compression adjuster	17 LS (low speed) 2 HS (high speed)	19
Rebound adjuster	22	24
Spring	80/250	84/250
Spring preload	4 mm	4 mm

TIGHTENING TORQUES - CHASSIS		
Collar bolt, front wheel spindle	M 24x1,5	40 Nm
Brake caliper, front	M 8	Loctite 243 + 25 Nm
Brake disk, front	M 6 10.9	Loctite 243 + 15 Nm
Brake disk, rear	M 6	Loctite 243 + 15 Nm
Clamping bolts, upper fork bridge	M 8	20 Nm
Clamping bolts, lower fork bridge	M 8	15 Nm
Clamping bolts, fork stubs	M 8	10 Nm
Collar nut, rear wheel spindle	M 20x1,5	80 Nm
Hexagon nut, swing arm bolt	M 16x1,5	100 Nm
Hexagon collar bolt, handlebar clamp	M 8	20 Nm
Allan head bolt, handlebar support	M 10	Loctite 243 + 40 Nm
Shock absorber, top	M 12	60 Nm
Shock absorber, bottom	M 12	60 Nm
Sprocket bolts	M 8	Loctite 243 + 35 Nm
Ball joint for push rod	M 6	Loctite 243 + 10 Nm
Engine mounting bolt	M 10	45 Nm
Engine brace	M 8	33 Nm
Screw adjusting ring spring preload shock abs.	M6	8 Nm
Spoke nipple	M4,5 /M5	6 Nm
Other bolts on chassis	M 6	10 Nm
	M 8	25 Nm
	M 10	45 Nm
Other collar nuts on chassis	M 6	15 Nm
	M 8	30 Nm
	M 10	50 Nm

## TECHNICAL SPECIFICATIONS - ENGINE 125 SX, EXC / 200 EXC 2005

ENGINE	125 SX	125 EXC	200 EXC
Design	Liquid-cooled, single-cylinder, two-stroke engine with intake and exhaust control		
Piston displacement	124.8 ccm	124.8 ccm	193 ccm
Bore / stroke	54 / 54.5 mm (2.126 / 2.145 in)	54 / 54.5 mm (2.126 / 2.145 in)	64 / 60 mm (2.52 / 2.362 in)
Fuel	unleaded fuel with at least RON 95 (USA = Premium RON 91), mixed with high grade two stroke oil		
Oil / gasoline ratio	1:40-1:60 when using high grade, two- stroke oil (Motorex Cross Power 2T). When in doubt, please contact your importer		
Crankshaft bearing	1 deep-groove ball bearing / 1 cylinder roller bearing		
Connecting rod bearing	needle bearing		
Piston pin bearing	needle bearing		
Piston	cast piston		
Piston ring	one plain compression ring	two plain compression rings	two plain compression rings
Dimension "X" <small>(upper edge piston- upper edge cylinder)</small>	0,0 mm		
Ignition timing	1.4 mm (0.055 in) (16.5°) BTDC	1.4 mm (0.055 in) (16.5°) BTDC	1.6 mm (0.063 in) (17°) BTDC
Spark plug	NGK BR9 EVX	NGK BR9 EVX	NGK BR 8 EG
Electrode gap	0,60 mm		
Dimension "Z" <small>(height of the control flap)</small>	43 mm (1.67 in)	43 mm (1.67 in)	47 mm (1.85 in)
Primary drive	straight cut spur gears, primary ratio 23:73		
Clutch	multiple disc clutch in oil bath, hydraulically operated (Motorex Kupplungs-Fluid 75)		
Transmission	5 speed, claw actuated	6 speed, claw actuated	6 speed, claw actuated
Gear ratio			
1st gear	13 : 32 "1S32"	12 : 33 "1G33"	12 : 33 "1G33"
2nd gear	"2S15" 15 : 30 "2S30"	"2S15" 15 : 31 "2G31"	"2S15" 15 : 31 "2G31"
3rd gear	"3S17H" 17 : 28 "3S28H"	"3S17H" 17 : 28 "3S28H"	"3S17H" 17 : 28 "3S28H"
4th gear	"4S19H" 19 : 26 "4S26"	"4S19H" 19 : 26 "4S26"	"4S19H" 19 : 26 "4S26"
5th gear	"5S21" 21 : 25 "5S25"	"5S21" 21 : 25 "5S25"	"5G17H" 17 : 19 "5G19H"
6th gear		"6G20" 20 : 20 "6G20"	"6G22H" 22 : 20 "6E20H"
Gear lubrication	0,7 liter Motorex Top Speed 4T 15W50		
Available chain sprockets	13t / 14t for chain 5/8 x 1/4"		
Coolant	1,2 litres, 50% anti freeze, 50% water, at least -25 °C (-13 °F)		
Ignition system	KOKUSAN 2K-1	KOKUSAN 2K-3	KOKUSAN 2K-3
Generator output	no generator	12V / 110 W	12V / 110 W
Ignition system USA	KOKUSAN 2K-1	KOKUSAN 2K-2	KOKUSAN 2K-2
Generator output	no generator	12V 40 W	12V 40 W
Carburetor	flat-slide carburetor, carburetor setting see table		
Air-filter	wet foam type air filter insert		

TIGHTENING TORQUES - ENGINE		
Flange bolts - cylinder-head	M7	18 Nm
Nuts-cylinder base	M8	30 Nm
Flywheel collar nut	M12x1	60 Nm
Nut for primary sprocket (LH thread)	M16x1,5	130 Nm
Nut for inner clutch hub	M18x1,5	130 Nm
Crankcase and clutch cover bolts	M6	10 Nm
Spark plug	M 14X1,25	25 Nm
Swingarm pivot	M16x1,5	100 Nm
Carburetor nipple (throttle slide)	M10x0,75	4 Nm
Carburetor plug	M18x1	4 Nm
Other screws	M 6	10 Nm
	M 8	25 Nm
	M 10	45 Nm

BASIC CARBURETOR SETTING					
	125 SX	125 EXC EU (4,2 KW)	125 EXC SIX-DAYS	200 EXC USA	200 EXC AUS 200 EXC EU (7 KW)
Carburetor	Keihin PWK 39	Keihin PWK 38 AG	Keihin PWK 38 AG	Keihin PWK 38 AG	Keihin PWK 38 AG
Carburetor setting mark	98SA0	8KTPB	85SA1	85SA01	8KTUB
Carburetor setting number	141102	070202	160202	080202	100202
Main jet	188 (185/190)	148 (180/185)	180 (185)	178 (180)	180 (178)
Idling jet	45 (48)	35 (45/48)	45 (48)	45 (48)	35 (45/48)
Starting jet	85	85	85	85	85
Jet needle	R1469D (R1468D)	R1472N (NOZE/NOZF)	NOZE (NOZF)	NOZE (NOZF)	R1475J (NOZE/NOZF)
Needle position from top	II	V	IV	III	III
Throttle valve	5.5	6.5	6.5	6.5	6.5
Air adjustment screw open	1,5	1,5	1,5	1,5	1,5
Performance restrictor	-	-	-	-	slide stop 36

TOLERANCES AND FITTING CLEARANCES	
Piston fitting clearance	125 = 0.06 mm 200 = 0.055 mm
Piston ring end cap	max. 0.40 mm
Connecting rod bearing - radial clearance	0.025–0.035 mm
Piston pin – radial clearance	0,030 mm
Transmission shafts end float	0.20–0.40 mm
Clutch springs - length	new = 39 mm, minimum length = 38 mm
Clutch discs	min. 2,9 mm (new 3,1 mm)
Crank stud - run out	0,02 mm
Crankshaft webs outer dimension	55 mm

GASKET THICKNESSES	
Crankcase	0,5 mm
Clutch cover	0,5 mm
Clutch driving cylinder	0.30 / 0.50 / 0.75 mm
Cylinder bottom gasket	as required
Available bottom gasket	0.07 / 0.15 / 0.20 / 0.25 / 0.40 / 0.50 / 0.75 mm

## TECHNICAL SPECIFICATIONS - CHASSIS 125 SX, EXC / 200 EXC 2005

CHASSIS	125 SX	125 EXC	200 EXC
Frame	Central chrome-moly-steel frame		
Fork	White Power – Upside down 48 MA		
Wheel travel front/rear	300/335 mm (11.8/13.2 in)		
Rear suspension	WP PDS 5018 (Progressive Damping System) shock absorber, aluminium swingarm		
Front brake	Disc brake with carbon-steel brake disc Ø 260 mm (10.2 in), brake caliper floated		
Rear brake	Disc brake with carbon-steel brake disc Ø 220 mm (8.7 in), brake caliper floated		
Brake discs	Wear limit 2.50 mm (0.1 in) front / 3.50 mm (0.14 in) rear		
Front tires	80/100 - 21" 51M, M59	90/90 - 21" MT 83	90/90 - 21" MT 83
Front tires USA	80/100 - 21" 51M, M59	–	80/100 - 21" 51M, M59
Air pressure offroad	1,0 bar (14 psi)	1,0 bar (14 psi)	1,0 bar (14 psi)
Air pressure road driver only	–	1,5 bar (21 psi)	1,5 bar (21 psi)
Rear tires	100/90 - 19" 57M, M70	120/90 - 18" MT 83	120/90 - 18" MT 83
Rear tires USA	100/90 - 19" 57M, M70	–	100/100 - 18" 59M, M402
Air pressure offroad	1,0 bar (14 psi)	1,0 bar (14 psi)	1,0 bar (14 psi)
Air pressure road driver only	–	2,0 bar (28 psi)	2,0 bar (28 psi)
Fuel tank capacity	7.5 liters (2 US gallons)	8.5 liters (2.2 US gallons)	8.5 / 10.5 liters (2.2 / 2.8 US gallons)
Final drive ratio	13:50 t	14:42 t	14:42 t
Final drive ratio USA	13:50 t	13:50 t	14:48 t
Chain	5/8 x 1/4 "		
Available final sprockets	38t, 40t, 42t, 45t, 48t, 49t, 50t, 51t, 52t		
Bulbs	headlight 12V 35/35W Bilux (base Ba20d) parking light 12V 5W (base W2, 1x9,5d) brake/rear light 12V 21/5W (base BaY15d) flasher light 12V 10W (base Ba15s) license plate illumination 12V 1,2W (base 1x4,6d)		
Steering head angle	63°		
Wheel base	1471 ± 10 mm (57.9 in ± 0.4 in)		
Seat height (unloaded)	925 mm (36,5 in)		
Ground clearance (unloaded)	390 mm (15,3 in)		

STANDARD ADJUSTMENT – FORK		
	125 SX	125/200 EXC
	WP 4860 MA-PA 14187A01	WP 4860 MA 14187A02
Compression adjuster	20	22
Rebound adjuster	20	21
Spring	4,2 N/mm	3,8 N/mm
Spring preload	5 mm	5 mm
Air chamber length	100 mm	110 mm
Fork oil	SAE 5	SAE 5

STANDARD ADJUSTMENT – SHOCK ABSORBER		
	125 SX	125/200 EXC
	WP PDS 5018 DCC 12187A01	WP PDS 5018 MCC 12187A02
Compression adjuster	15 LS (low speed) 1,5 HS (high speed)	15 –
Rebound adjuster	22	22
Spring	72 N/mm linear	72 N/mm linear
Spring preload	7 mm	7 mm

TIGHTENING TORQUES – CHASSIS		
Collar screw, front wheel spindle	M24x1,5	40 Nm
Brake caliper, front	M8	Loctite 243 + 25 Nm
Brake disks	M6	Loctite 243 + 10 Nm
Clamping screws, upper fork bridge (EXC)	M8	20 Nm
Clamping screws, lower fork bridge (EXC)	M8	15 Nm
Clamping screws, upper fork bridge (SX)	M8	15 Nm
Clamping screws, lower fork bridge (SX)	M8	10 Nm
Clamping screws, fork stubs	M8	10 Nm
Collar nut, rear wheel spindle	M20x1,5	80 Nm
Hexagon nut, swing arm bolt	M16x1,5	100 Nm
Hexagon collar screw, handlebar clamp	M8	Loctite 243 + 20 Nm
Allan head screw, handlebar support	M10	Loctite 243 + 40 Nm
Shock absorber, top	M12	80 Nm
Shock absorber, bottom	M12	80 Nm
Sprocket screws	M8	Loctite 243 + 35 Nm
Ball joint for push rod	M6	Loctite 243 + 10 Nm
Engine mounting bolt	M10	60 Nm
Engine brace	M8	33 Nm
Screw adjusting ring spring preload shock abs.	M6	8 Nm
Spoke nipple	M4,5 / M5	5 Nm
Other screws on chassis	M6	10 Nm
	M8	25 Nm
	M10	45 Nm
Other collar nuts on chassis	M6	15 Nm
	M8	30 Nm
	M10	50 Nm

## TECHNICAL SPECIFICATIONS - ENGINE 125 SX / SXS / EXC / EXC SIX DAYS 2006

ENGINE	125 SX / SXS	125 EXC / EXC SIX DAYS
Design	Liquid-cooled, single-cylinder, two-stroke engine with intake and exhaust control	
Piston displacement	124.8 ccm	124.8 ccm
Bore / stroke	54 / 54,5 mm	54 / 54,5 mm
Fuel	SX - unleaded fuel with at least RON 95 (USA = Premium PON 91), mixed with high grade two stroke oil SXS - unleaded fuel with at least RON 98 (USA = Premium PON 94), mixed with high grade two stroke oil	
Oil / gasoline ratio	1:40-1:60 (SXS - 1:40) when using high grade, two- stroke oil (Motorex Cross Power 2T) When in doubt, please contact your importer	
Crankshaft bearing	1 deep-groove ball bearing / 1 cylinder roller bearing	
Connecting rod bearing	needle bearing	needle bearing
Piston pin bearing	needle bearing	needle bearing
Piston	cast piston	cast piston
Piston ring	one plain compression ring	two plain compression rings
Dimension "X" <small>(upper edge piston- upper edge cylinder)</small>	0,0 mm	0,0 mm
Ignition timing	1,4 mm (16,5°) BTDC	1,4 mm (16,5°) vor BTDC
Spark plug	SX - NGK BR9 EVX SXS - NGK R6385-105P oder NGK R7376-10	NGK BR9 EVX
Electrode gap	0,60 mm	0,60 mm
Dimension "Z" <small>(height of the control flap)</small>	43,5 mm	43,5 mm
Primary drive	straight cut spur gears, primary ratio 23 : 73	
Clutch	multiple disc clutch in oil bath, hydraulically operated (Motorex Kupplungs-Fluid 75)	
Transmission	6 speed, claw actuated	6 speed, claw actuated
Gear ratio		
1st gear	13 : 32 "1S32"	12 : 33 "1G33"
2nd gear	"2S15" 15 : 30 "2S30"	"2S15" 15 : 31 "2G31"
3rd gear	"3S17H" 17 : 28 "3S28H"	"3S17H" 17 : 28 "3S28H"
4th gear	"4S20H" 20 : 28 "4S28"	"4S19H" 19 : 26 "4S26"
5th gear	"5S19H" 19 : 23 "5S23H"	"5S21" 21 : 25 "5S25"
6th gear	"6S22H" 22 : 24 "6S24H"	"6G20" 20 : 20 "6G20"
Gear lubrication	0,7 Liter Motorex Top Speed 4T 15W50	0,7 Liter Motorex Top Speed 4T 15W50
Available chain sprockets	13t / 14t for chain 5/8 x 1/4	13t / 14t for chain 5/8 x 1/4
Coolant	1.2 litres, 40% anti freeze, 60% distilled water, at least -25 °C	
Ignition system	KOKUSAN 2K-1	KOKUSAN 2K-3
Generator output	no generator	12V / 110 W
Carburetor	flat-slide carburetor, carburetor setting see table	flat-slide carburetor, carburetor setting see table
Air-filter	wet foam type air filter insert	wet foam type air filter insert



## TECHNICAL SPECIFICATIONS - ENGINE 200 EXC / XC-W / XC 2006

ENGINE	200 EXC	200 XC-W	200 XC
Design	Liquid-cooled, single-cylinder, two-stroke engine with intake and exhaust control		
Piston displacement	193 ccm	193 ccm	193 ccm
Bore / stroke	64 / 60 mm	64 / 60 mm	64 / 60 mm
Fuel	unleaded fuel with at least RON 95 (USA = Premium RON 91), mixed with high grade two stroke oil		
Oil / gasoline ratio	1:40-1:60 when using high grade, two- stroke oil (Motorex Cross Power 2T). When in doubt, please contact your importer		
Crankshaft bearing	1 deep-groove ball bearing / 1 cylinder roller bearing		
Connecting rod bearing	needle bearing	needle bearing	needle bearing
Piston pin bearing	needle bearing	needle bearing	needle bearing
Piston	cast piston	cast piston	cast piston
Piston ring	two plain compression rings	two plain compression rings	two plain compression rings
Dimension "X" <small>(upper edge piston- upper edge cylinder)</small>	0,0 mm	0,0 mm	0,0 mm
Ignition timing	1,6 mm (17°) BTDC	1,6 mm (17°) BTDC	1,6 mm (17°) BTDC
Spark plug	NGK BR 8 EG	NGK BR 8 EG	NGK BR 8 EG
Electrode gap	0,60 mm	0,60 mm	0,60 mm
Dimension "Z" <small>(height of the control flap)</small>	47 mm	47 mm	47 mm
Primary drive	straight cut spur gears, primary ratio 23 : 73		
Clutch	multiple disc clutch in oil bath, hydraulically operated (Motorex Kupplungs-Fluid 75)		
Transmission	6 speed, claw actuated	6 speed, claw actuated	6 speed, claw actuated
Gear ratio			
1st gear	12 : 33 "1G33"	12 : 33 "1G33"	13 : 32 "1S32"
2nd gear	"2S15" 15 : 31 "2G31"	"2S15" 15 : 31 "2G31"	"2S15" 15 : 30 "2S30"
3rd gear	"3S17H" 17 : 28 "3S28H"	"3S17H" 17 : 28 "3S28H"	"3S17H" 17 : 28 "3S28H"
4th gear	"4S19H" 19 : 26 "4S26"	"4S19H" 19 : 26 "4S26"	"4S19H" 19 : 26 "4S26"
5th gear	"5G17H" 17 : 19 "5G19H"	"5G17H" 17 : 19 "5G19H"	"5S21" 21 : 25 "5S25"
6th gear	"6G22H" 22 : 20 "6E20H"	"6G22H" 22 : 20 "6E20H"	"6S22" 22 : 23 "6S23"
Gear lubrication	0,7 Liter Motorex Top Speed 4T 15W50		
Available chain sprockets	13t / 14t for chain 5/8 x 1/4		
Coolant	1.2 litres, 40% anti freeze, 60% distilled water, at least -25 °C		
Ignition system	KOKUSAN 2K-3	KOKUSAN 2K-2	KOKUSAN 2K-2
Generator output	12V / 110 W	12V / 40 W	12V / 40 W
Carburetor	flat-slide carburetor, carburetor setting see table		
Air-filter	wet foam type air filter insert		

TIGHTENING TORQUES - ENGINE		
Flange bolts - cylinder-head	M7	18 Nm
Nuts-cylinder base	M8	30 Nm
Flywheel collar nut	M12x1	60 Nm
Nut for primary sprocket (LH thread)	M16x1.5	130 Nm
Nut for inner clutch hub	M18x1.5	130 Nm
Collar screw for clutch spring	M6	10 Nm
Oil drain plug	M12x1.5	20 Nm
Oil drain plug	M10x1	15 Nm
Drain plug for water pump cover	M10x1	15 Nm
Collar screw for water pump cover	M6	Loctite 243 + 10 Nm
Water pump wheel	M5	Loctite 243 + 6 Nm
Crankcase and clutch cover bolts	M6	10 Nm
Collar screws for ignition cover	M5	6 Nm
Collar screws for exhaust flange	M5	6 Nm
Spark plug	M14x1.25	25 Nm
Collar screws for ignition system	M5	6 Nm
Collar screw for kickstarter lever	M8	Loctite 243 + 25 Nm
Other screws	M 6	10 Nm
	M 8	25 Nm
	M 10	45 Nm

BASIC CARBURETOR SETTING					
	125 SX 125 SXS	125 EXC EU 4,2 KW	125 EXC SIX DAYS	200 XC 200 XC-W	200 EXC AUS 7 KW 200 EXC EU 7 KW
Carburetor	Keihin PWK 39	Keihin PWK 36S AG	Keihin PWK 36S AG	Keihin PWK 38 AG	Keihin PWK 38 AG
Carburetor setting mark	98SA1	8KTPC	FK0070	FJ0040	8KTUC
Main jet	188 (185/190)	145 (168/170/172)	170 (168/172)	172 (170/175)	180 (170/172/175)
Idling jet	45 (48)	35 (45/48)	45	45	35 (45)
Starting jet	85	85	85	85	85
Jet needle	R1469D (R1468D)	R1472N (NOZE/NOZF)	NOZE (NOZF)	NOZE (NOZF)	R1475J (NOZE/NOZF)
Needle position from top	II	V	IV	III	III
Throttle valve	5.5	7	7	6.5	6.5
Air adjustment screw open	1,5	1,5	1	1,5	1,5
Performance restrictor	-	-	-	-	slide stop 36

TOLERANCES AND FITTING CLEARANCES	
Piston fitting clearance	125 = 0.06 mm      200 = 0.055 mm
Piston ring end cap	max. 0.40 mm
Connecting rod bearing - radial clearance	0.025-0.035 mm
Piston pin - radial clearance	0.030 mm
Transmission shafts end float	0.2-0.4 mm
Clutch springs - length	new = 40 mm, minimum length = 39 mm
Clutch discs	min. 2.9 mm (new 3.0 mm)
Crank stud - run out	0.02 mm
Crankshaft webs outer dimension	55 mm

GASKET THICKNESSES	
Crankcase	0.5 mm
Clutch cover	0.5 mm
Clutch driving cylinder	0.3 / 0.5 / 0.75 mm
Cylinder bottom gasket	as required
Available bottom gasket	0.07 / 0.15 / 0.20 / 0.25 / 0.40 / 0.50 / 0.75 mm

## TECHNICAL SPECIFICATIONS - CHASSIS 125 SX / SXS / EXC / EXC SIX DAYS 2006

CHASSIS	125 SX / SXS	125 EXC / EXC SIX DAYS
Frame	Central chrome-moly-steel frame	
Fork	WP – Up Side Down 4860	
Fork offset (caster)	SX - adjustable 18mm/20mm SXS - adjustable 17.5mm/20.5mm	EXC - 20mm EXC SIX DAYS - adjustable 18mm/20mm
Wheel travel front/rear	300/335 mm	
Rear suspension	WP PDS 5018 (Progressive Damping System) shock absorber, aluminium swingarm	
Front brake	Disc brake with perforated brake disc Ø 260 mm, brake caliper floated	
Rear brake	Disc brake with perforated brake disc Ø 220 mm, brake caliper floated	
Brake discs	Wear limit 2.50 mm front / 3.50 mm rear	
Front tires	80/100-21" Bridgestone M59	90/90-21" Pirelli MT 83
Air pressure offroad	1,0 bar	1,0 bar
Air pressure road driver only	–	1,5 bar
Rear tires	100/90-19" Bridgestone M70	120/90-18" Pirelli MT 83
Air pressure offroad	1,0 bar	1,0 bar
Air pressure road driver only	–	2,0 bar
Fuel tank capacity	SX - approx. 7.5 liters / SXS - approx. 8.5 liters	approx. 8.5 liters
Final drive ratio	13:50 t	EXC - 14:42 t (13:50 t) / EXC SIXS DAYS - 13:50 t
Chain	5/8 x 1/4 "	
Available final sprockets	38t, 40t, 42t, 45t, 48t, 49t, 50t, 51t, 52t	
Bulbs		
headlight	-	12V 35/35W (base Ba20d)
parking light	-	12V 5W (base W2.1x9.5d)
brake/rear light	-	12V 21/5W (base BaY15d)
flasher light	-	12V 10W (base Ba15s)
instrument light	-	12V 1.2W (base W2.1x4.6d)
Steering head angle	63°	
Wheel base	1471 ± 10 mm	
Seat height (unloaded)	925 mm	
Ground clearance (unloaded)	390 mm	
Weight (without fuel)	92,4 kg	98,6 kg

### STANDARD ADJUSTMENT – FORK

	125 SX	125 SXS	125 EXC	125 EXC SIX DAYS
	WP 4860 MXMA PA 14.18.7B.01	WP 4860 MXMA PA CC 14.18.7B.14	WP 4860 MXMA 14.18.7B.02	WP 4860 MXMA PA 14.18.7B.27
Compression adjuster	18	22	20	20
Rebound adjuster	20	24	21	20
Spring	4.2 N/mm	4.2 N/mm	3.8 N/mm	4.0 N/mm
Spring preload	5 mm	5 mm	5 mm	3 mm
Air chamber length	100 mm	-	110 mm	110 mm
Fork oil	SAE 5	SAE 5	SAE 5	SAE 5

### STANDARD ADJUSTMENT – SHOCK ABSORBER

	125 SX	125 SXS	125 EXC	125 EXC SIX DAYS
	WP 5018 PDS DCC 12.18.7B.01	WP 5018 PDS II DCC 12.18.7B.10	WP 5018 PDS MCC 12.18.7B.02	WP 5018 PDS DCC 12.18.7B.24
Compression adjuster	15 LS (low speed) 2.5 HS (high speed)	12 LS (low speed) 2 HS (high speed)	15 –	15 LS (low speed) 1.5 HS (high speed)
Rebound adjuster	22	25	22	22
Spring	72 N/mm linear	80/250	72 N/mm linear	72 N/mm linear
Spring preload	5 mm	5 mm	4 mm	5 mm

## TECHNICAL SPECIFICATIONS - CHASSIS 200 EXC / XC-W / XC 2006

CHASSIS	200 EXC	200 XC-W	200 XC
Frame	Central chrome-moly-steel frame		
Fork	WP – Up Side Down 48 MA		WP – Up Side Down 48 MA-PA
Fork offset (caster)	20mm		adjustable 18mm/20mm
Wheel travel front/rear	300/335 mm		
Rear suspension	WP PDS 5018 (Progressive Damping System) shock absorber, aluminium swingarm		
Front brake	Disc brake with perforated brake disc Ø 260 mm, brake caliper floated		
Rear brake	Disc brake with perforated brake disc Ø 220 mm, brake caliper floated		
Brake discs	Wear limit 2.50 mm front / 3.50 mm rear		
Front tires	90/90-21" Pirelli MT 83	80/100-21" Bridgestone M59	80/100-21" Bridgestone M59
Air pressure offroad	1,0 bar	1,0 bar	1,0 bar
Air pressure road driver only	1,5 bar	1,5 bar	-
Rear tires	120/90-18" Pirelli MT 83	100/100-18" Bridgestone M402	100/100-18" Bridgestone M402
Air pressure offroad	1,0 bar	1,0 bar	1,0 bar
Air pressure road driver only	2,0 bar	2,0 bar	-
Fuel tank capacity	approx. 8.5 liters or 10 liters		approx. 11 liters
Final drive ratio	14:42 t (14:48 t)	14:48 t	13:50 t
Chain	5/8 x 1/4 "		
Available final sprockets	38t, 40t, 42t, 45t, 48t, 49t, 50t, 51t, 52t		
Bulbs	area code ZA only		
headlight	12V 35/35W (base Ba20d)	12V 35/35W (base Ba20d)	-
parking light	12V 5W (base W2.1x9.5d)	12V 5W (base W2.1x9.5d)	-
brake/rear light	12V 21/5W (base BaY15d)	12V 21/5W (base BaY15d)	-
flasher light	12V 10W (base Ba15s)	-	-
instrument light	12V 1.2W (base W2.1x4.6d)	12V 1.2W (base W2.1x4.6d)	-
Steering head angle	63°		
Wheel base	1471 ± 10 mm		
Seat height (unloaded)	925 mm		
Ground clearance (unloaded)	390 mm		
Weight (without fuel)	99,8 kg	97,4 kg	96 kg

### STANDARD ADJUSTMENT – FORK

	200 EXC / 200 XC-W	200 XC
	WP 4860 MXMA 14.18.7B.02	WP 4860 MXMA PA 14.18.7B.27
Compression adjuster	20	20
Rebound adjuster	21	20
Spring	3,8 N/mm	4,0 N/mm
Spring preload	5 mm	3 mm
Air chamber length	110 mm	110 mm
Fork oil	SAE 5	SAE 5

### STANDARD ADJUSTMENT – SHOCK ABSORBER

	200 EXC / 200 XC-W	200 XC
	WP 5018 PDS MCC 12.18.7B.02	WP 5018 PDS DCC 12.18.7B.24
Compression adjuster	15 –	15 LS (low speed) 1,5 HS (high speed)
Rebound adjuster	22	22
Spring	72 N/mm linear	72 N/mm linear
Spring preload	4 mm	5 mm

TIGHTENING TORQUES – CHASSIS		
Collar screw, front wheel spindle	M24x1.5	40 Nm
Brake caliper, front	M8	Loctite 243 + 25 Nm
Brake disks screws	M6	14 Nm
Clamping screws, upper fork bridge (EXC / XC-W)	M8	20 Nm
Clamping screws, lower fork bridge (EXC / XC-W)	M8	15 Nm
Clamping screws, upper fork bridge (SX / XC / EXC SIX DAYS)	M8	17 Nm
Clamping screws, lower fork bridge (SX / XC / EXC SIX DAYS)	M8	12 Nm
Steering head screw, top	M20x1.5	10 Nm
Steering head screw, bottom	M20x1.5	60 Nm (Alltight-lock)
Clamping screws, fork stubs	M8	15 Nm
Collar nut, rear wheel spindle	M20x1.5	80 Nm
Hexagon nut, swing arm bolt	M16x1.5	100 Nm
Hexagon collar screw, handlebar clamp	M8	20 Nm
Allan head screw, handlebar support	M10	Loctite 243 + 40 Nm
Shock absorber, top	M12	70 Nm (Alltight-lock)
Shock absorber, bottom	M12	70 Nm (Alltight-lock)
Sprocket screws	M8	35 Nm (to nut)
Ball joint for push rod	M6	10 Nm
Engine mounting bolt	M10	60 Nm
Engine brace	M8	33 Nm
Screw adjusting ring spring preload shock abs.	M6	8 Nm
Rim lock	M8	10 Nm
Spoke nipple	M4.5 / M5	4.5 - 6 Nm
Collar nut to fasten seat	M12x1	20 Nm
Screw for engine sprocket	M10	Loctite 242 + 60 Nm
SLS valve	M16x1.5	15 Nm
Other screws on chassis	M6	10 Nm
	M8	25 Nm
	M10	45 Nm
Other collar nuts on chassis	M6	15 Nm
	M8	30 Nm
	M10	50 Nm

## TECHNICAL SPECIFICATIONS - ENGINE 125 SX/SXS/EXC/EXC SIX DAYS/144 SX 2007

ENGINE	125 SX/SXS	144 SX	125 EXC / EXC SIX DAYS
Design	Liquid-cooled, single-cylinder, two-stroke engine with intake and exhaust control		
Piston displacement	124.8 cm <sup>3</sup>	143.6 cm <sup>3</sup>	124.8 cm <sup>3</sup>
Bore / stroke	54 / 54.5 mm	56 / 58.4 mm	54 / 54.5 mm
Fuel	unleaded fuel with at least RON 95 (USA = Premium PON 91), mixed with high grade two stroke oil		
Oil / gasoline ratio	1:40		1:60
	when using high grade, two- stroke oil (Motorex Cross Power 2T)		
Crankshaft bearing	1 deep-groove ball bearing / 1 cylinder roller bearing		
Connecting rod bearing	needle bearing		
Piston pin bearing	needle bearing		
Piston	cast piston		
Piston ring	two plain compression rings		
Dimension „X“ <small>(upper edge piston- upper edge cylinder)</small>	0.0 mm		
Ignition timing	1.4 mm (16.5°) BTDC		
Spark plug	NGK BR9 EVX	NGK BR9 ECMVX	NGK BR9 EVX
Electrode gap	0.60 mm	0.70 - 0.80 mm	0.60 mm
Dimension „Z“ <small>(height of the control flap)</small>	43.5 mm	43.1 mm	43.5 mm
Primary drive	straight cut spur gears 23 : 73		
Available chain sprockets	13t /14t / 15t for chain 5/8 x 1/4"		
Clutch	multiple disc clutch in oil bath, hydraulically operated (Motorex hydraulic fluid 75)		
Transmission	6 speed, claw actuated		
Gear ratio			
1st gear	13 : 32 „1S32“		12 : 33 „1G33“
2nd gear	„2S15“	15 : 30 „2S30“	„2S15“ 15 : 31 „2G31“
3rd gear	„3S17H“	17 : 28 „3S28H“	„3S17H“ 17 : 28 „3S28H“
4th gear	„4S20H“	20 : 28 „4S28“	„4S19H“ 19 : 26 „4S26“
5th gear	„5S19H“	19 : 23 „5S23“H	„5S21“ 21 : 25 „5S25“
6th gear	„6S22H“	22 : 24 „6S24“H	„6G20“ 20 : 20 „6G20“
Gear lubrication	0,7 liter Motorex Top Speed 4T 15W50		
Available chain sprockets	13t / 14t / 15t for chain 5/8 x 1/4"		
Coolant	1.2 litres, 50% anti freeze, 50% distilled water, at least -25 °C (-13 °F)		
Ignition system	KOKUSAN 2K-1		KOKUSAN 2K-3
Carburetor	flat-slide carburetor, carburetor setting see table		
Air-filter	wet foam type air filter insert		

## TECHNICAL SPECIFICATIONS - ENGINE 200 EXC / XC-W / XC 2007

ENGINE	200 EXC	200 XC-W	200 XC
Design	Liquid-cooled, single-cylinder, two-stroke engine with intake and exhaust control		
Piston displacement	193 ccm		
Bore / stroke	64 / 60 mm		
Fuel	unleaded fuel with at least RON 95 (USA = Premium RON 91), mixed with high grade two stroke oil		
Oil / gasoline ratio	1:60 when using high grade, two- stroke oil (Motorex Cross Power 2T).		
Crankshaft bearing	1 deep-groove ball bearing / 1 cylinder roller bearing		
Connecting rod bearing	needle bearing		
Piston pin bearing	needle bearing		
Piston	cast piston		
Piston ring	two plain compression rings		
Dimension „X“ <small>(upper edge piston- upper edge cylinder)</small>	0,0 mm		
Ignition timing	1.6 mm (17°) BTDC		
Spark plug	NGK BR 8 EG		
Electrode gap	0,60 mm		
Dimension „Z“ <small>(height of the control flap)</small>	47 mm		
Primary drive	straight cut spur gears, primary ratio 23:73		
Clutch	multiple disc clutch in oil bath, hydraulically operated (Motorex hydraulic fluid 75)		
Transmission	6 speed, claw actuated		
Gear ratio			
1st gear	13 : 33 „1G33“		13 : 32 „1S32“
2nd gear	„2S15“	15 : 31 „2G31“	„2S15“ 15 : 30 „2S30“
3rd gear	„3S17H“	17 : 28 „3S28H“	„3S17H“ 17 : 28 „3S28H“
4th gear	„4S19H“	19 : 26 „4S26“	„4S19H“ 19 : 26 „4S26H“
5th gear	„5G17H“	17 : 19 „5G19H“	„5S21“ 21 : 25 „5S25“
6th gear	„6G22H“	22 : 20 „6E20H“	„6G22“ 22 : 23 „6S23“
Gear lubrication	0,7 liter Motorex Top Speed 4T 15W50		
Available chain sprockets	13t / 14t / 15t for chain 5/8 x 1/4"		
Coolant	1.2 litres, 50% anti freeze, 50% distilled water, at least -25 °C (-13 °F)		
Ignition system	KOKUSAN 2K-3	KOKUSAN 2K-2	
Generator output	12V / 110 W	12V / 40 W	
Carburetor	flat-slide carburetor, carburetor setting see table		
Air-filter	wet foam type air filter insert		

TIGHTENING TORQUES - ENGINE		
Flange bolts - cylinder-head	M7	18 Nm
Nuts-cylinder base	M8	35 Nm
Flywheel collar nut	M12x1	60 Nm
Nut for primary sprocket (LH thread)	M16x1.5	Loctite 243 + 130 Nm
Nut for inner clutch hub	M18x1.5	130 Nm
Collar screw for clutch spring	M6	10 Nm
Oil drain plug	M12x1.5	20 Nm
Oil drain plug	M10x1	15 Nm
Drain plug for water pump cover	M10x1	15 Nm
Collar screw for water pump cover	M6	Loctite 243 + 10 Nm
Water pump wheel	M5	Loctite 243 + 6 Nm
Crankcase and clutch cover bolts	M6	10 Nm
Collar screws for ignition cover	M5	5 Nm
Collar screws for exhaust flange	M5	6 Nm
Spark plug	M14x1.25	25 Nm
Collar screws for ignition system	M5	6 Nm
Collar screw for kickstarter lever	M8	Loctite 243 + 25 Nm
Other screws	M 6	10 Nm
	M 8	25 Nm
	M 10	45 Nm

BASIC CARBURETOR SETTING						
	125 SX 125 SXS	144 SX	125 EXC EU 4,2 KW	125 EXC SIX DAYS	200 XC 200 XC-W	200 EXC AUS 7 KW 200 EXC EU 7 KW
Carburetor: Keihin	PWK 39	PWK 39	PWK 36S AG	PWK 36S AG	PWK 36S AG	PWK 36S AG
Carburetor setting mark	98SA1	TBC	8KTPC	FK0070	FK0130	8KTUD
Main jet	188 (185/190)	202 (200/205)	145 (168/170/172)	170 (168/172)	162 (160/165)	162 (160/165)
Idling jet	45 (48)	45 (48)	35 (45/48)	45	42	35 (42)
Starting jet	85	85	85	85	85	85
Jet needle	R1469D (R1468D)	N3CG (N3CH,N3CF)	R1472N (NOZE/NOZF)	NOZE (NOZF)	NOZF (NOZG)	R1475J (NOZG/NOZF)
Needle position from top	II	III	V	IV	IV	III
Throttle valve	5.5	5.5	7	7	7	7
Air adjustment screw open	1.5	1.5	1.5	1	1	1
Performance restrictor	-	-	-	-	-	slide stop 38

TOLERANCES AND FITTING CLEARANCES	
Piston fitting clearance	125/144 = 0.06 mm                      200 = 0.055 mm
Piston ring end cap	max. 0.40 mm
Connecting rod bearing - radial clearance	0.025-0.035 mm
Piston pin - radial clearance	0.030 mm
Transmission shafts end float	0.2-0.4 mm
Clutch springs - length	new = 40 mm, minimum length = 39 mm
Clutch discs	min. 2.9 mm (new 3.0 mm)
Crank stud - run out	0.02 mm
Crankshaft webs outer dimension	55 mm

GASKET THICKNESSES	
Crankcase	0.5 mm
Clutch cover	0.5 mm
Clutch driving cylinder	0.3 / 0.5 / 0.75 mm
Cylinder bottom gasket	as required
Available bottom gasket	0.20 / 0.25 / 0.40 / 0.50 / 0.75 mm



## TECHNICAL SPECIFICATIONS - CHASSIS 125 SX/SXS/EXC/EXC SIX DAYS/144 SX 2007

CHASSIS	125 SX/SXS, 144 SX	125 EXC / EXC SIX DAYS
Frame	Central chrome-moly-steel frame	
Fork	WP – Up Side Down 4860	
Fork offset (caster)	SX - adjustable 18mm/20mm SXS - adjustable 17.5mm/20.5mm	EXC - 20mm EXC SIX DAYS - adjustable 18mm/20mm
Wheel travel front/rear	300/335 mm	
Rear suspension	WP PDS 5018 (Progressive Damping System) shock absorber, aluminium swingarm	
Front brake	Disc brake with perforated brake disc Ø 260 mm, brake caliper floated	
Rear brake	Disc brake with perforated brake disc Ø 220 mm, brake caliper floated	
Brake discs	Wear limit 2.50 mm front / 3.50 mm rear (SXS 3.80 mm)	
Front tires	80/100-21" Bridgestone M59	90/90-21" Pirelli MT 83
Air pressure offroad	1,0 bar	1,0 bar
Air pressure road driver only	–	1,5 bar
Rear tires	100/90-19" Bridgestone M70	120/90-18" Pirelli MT 83
Air pressure offroad	1,0 bar	1,0 bar
Air pressure road driver only	–	2,0 bar
Fuel tank capacity	approx. 7.5 liters	approx. 8.5 liters
Final drive ratio	13:50 t	EXC - 14:42 t (13:50 t)/EXC SIXS DAYS - 13:50 t
Chain	5/8 x 1/4 "	
Available final sprockets	38t, 40t, 42t, 45t, 48t, 49t, 50t, 51t, 52t	
Bulbs		
headlight	-	12V 35/35W (base Ba20d)
parking light	-	12V 5W (base W2.1x9.5d)
brake/rear light	-	12V 21/5W (base BaY15d)
flasher light	-	12V 10W (base Ba15s)
instrument light	-	12V 1.2W (base W2.1x4.6d)
Steering head angle	63°	
Wheel base	1471 ± 10 mm	
Seat height (unloaded)	925 mm	
Ground clearance (unloaded)	390 mm	
Weight (without fuel)	89,5 kg	98,6 kg

### STANDARD ADJUSTMENT – FORK

	125/144 SX	125 SXS	125 EXC	125 EXC SIX DAYS
	WP 4860 MXMA CC 14.18.7C.01	WP 4860 MXMA CC 14.18.7C.14	WP 4860 MXMA 14.18.7C.02	WP 4860 MXMA PA 14.18.7C.27
Compression adjuster	18	15	20	18
Rebound adjuster	20	22	20	20
Spring	4.2 N/mm	4.2 N/mm	4.0 N/mm	4.2 N/mm
Fork oil	SAE 5	SAE 5	SAE 5	SAE 5

### STANDARD ADJUSTMENT – SHOCK ABSORBER

	125/144 SX	125 SXS	125 EXC	125 EXC SIX DAYS
	WP 5018 PDS DCC 12.18.7C.01	WP 5018 PDS DCC 12.18.7C.10	WP 5018 PDS MCC 12.18.7C.02	WP 5018 PDS DCC 12.18.7B.24
Compression adjuster	15 LS (low speed) 1 HS (high speed)	10 LS (low speed) 20 HS (high speed)	17	15 LS (low speed) 1.25 HS (high speed)
Rebound adjuster	25	20	26	24
Spring	60/250	63/250	72/250	72/250
Spring preload	5 mm	4 mm	4 mm	5 mm

## TECHNICAL SPECIFICATIONS - CHASSIS 200 EXC / XC-W / XC 2007

CHASSIS	200 EXC	200 XC-W	200 XC
Frame	Central chrome-moly-steel frame		
Fork	WP – Up Side Down 4860		
Fork offset (caster)	20mm		adjustable 18mm/20mm
Wheel travel front/rear	300/335 mm		
Rear suspension	WP PDS 5018 (Progressive Damping System) shock absorber, aluminium swingarm		
Front brake	Disc brake with perforated brake disc Ø 260 mm, brake caliper floated		
Rear brake	Disc brake with perforated brake disc Ø 220 mm, brake caliper floated		
Brake discs	Wear limit 2.50 mm front / 3.50 mm rear		
Front tires	90/90-21" Pirelli MT 83	80/100-21" Bridgestone M59	
Air pressure offroad	1,0 bar	1,0 bar	
Air pressure road driver only	1,5 bar	1,5 bar	
Rear tires	120/90-18" Pirelli MT 83	100/100-18" Bridgestone M402	
Air pressure offroad	1,0 bar	1,0 bar	
Air pressure road driver only	2,0 bar	2,0 bar	
Fuel tank capacity	approx. 8.5 liters or 10 liters	approx. 11 liters	
Final drive ratio	14:42 t (14:48 t)	14:48 t	
Chain	5/8 x 1/4 "		
Available final sprockets	38t, 40t, 42t, 45t, 48t, 49t, 50t, 51t, 52t		
Bulbs	area code ZA only		
headlight	12V 35/35W (base Ba20d)	12V 35/35W (base Ba20d)	-
parking light	12V 5W (base W2.1x9.5d)	12V 5W (base W2.1x9.5d)	-
brake/rear light	12V 21/5W (base BaY15d)	12V 21/5W (base BaY15d)	-
flasher light	12V 10W (base Ba15s)	-	-
instrument light	12V 1.2W (base W2.1x4.6d)	12V 1.2W (base W2.1x4.6d)	-
Steering head angle	63°		
Wheel base	1471 ± 10 mm		
Seat height (unloaded)	925 mm		
Ground clearance (unloaded)	390 mm		
Weight (without fuel)	99,8 kg	98 kg	97,2 kg

### STANDARD ADJUSTMENT – FORK

	200 EXC / 200 XC-W	200 XC
	WP 4860 MXMA 14.18.7C.02	WP 4860 MXMA PA 14.18.7C.27
Compression adjuster	20	18
Rebound adjuster	20	20
Spring	4,0 N/mm	4,2 N/mm
Air chamber length	110 mm	110 mm
Fork oil	SAE 5	SAE 5

### STANDARD ADJUSTMENT – SHOCK ABSORBER

	200 EXC / 200 XC-W	200 XC
	WP 5018 PDS MCC 12.18.7C.02	WP 5018 PDS DCC 12.18.7C.27
Compression adjuster	17 –	15 LS (low speed) 1,25 HS (high speed)
Rebound adjuster	22	24
Spring	72/250	72/250
Spring preload	4 mm	5 mm

TIGHTENING TORQUES – CHASSIS		
Collar screw, front wheel spindle	M24x1,5	40 Nm
Brake caliper, front	M8	Loctite 243 + 25 Nm
Brake disks	M6	14 Nm
Screw steering head	M20x1,5	10 Nm
Lower Screw steering head	M20x1,5	Loctite 243 + 60 Nm
Clamping screws, upper fork bridge (EXC / XC-W)	M8	17 Nm
Clamping screws, lower fork bridge (EXC / XC-W)	M8	12 Nm
Clamping screws, upper steering stem	M8	Loctite 243 + 17 Nm
Clamping screws, upper fork bridge (SX / XC / EXC Six Days)	M8	20 Nm
Clamping screws, lower fork bridge (SX / XC / EXC Six Days)	M8	15 Nm
Clamping screws, fork stubs	M8	15 Nm
Collar nut, rear wheel spindle	M20x1,5	80 Nm
Hexagon nut, swing arm bolt	M16x1,5	100 Nm
Hexagon collar screw, handlebar clamp	M8	20 Nm
Allan head screw, handlebar support	M10	Loctite 243 + 40 Nm
Shock absorber, top	M12	Loctite 243 + 70 Nm
Shock absorber, bottom	M12	Loctite 243 + 70 Nm
Sprocket screws	M8	Loctite 243 + 35 Nm
Ball joint for push rod	M6	10 Nm
Engine mounting bolt	M10	60 Nm
Engine brace	M8	33 Nm
Screw adjusting ring spring preload shock abs.	M6	8 Nm
Spoke nipple	M4,5 / M5	5 Nm
Other screws on chassis	M6	10 Nm
	M8	25 Nm
	M10	45 Nm
Other collar nuts on chassis	M6	15 Nm
	M8	30 Nm
	M10	50 Nm

## TECHNICAL SPECIFICATIONS - ENGINE 125 SX/EXC/EXC SIX DAYS/144 SX 2008

ENGINE	125 SX	144 SX	125 EXC / EXC SIX DAYS
Design	Liquid-cooled, single-cylinder, two-stroke engine with intake and exhaust control		
Piston displacement	124.8 cm <sup>3</sup>	143.6 cm <sup>3</sup>	124.8 cm <sup>3</sup>
Bore / stroke	54 / 54.5 mm	56 / 58.4 mm	54 / 54.5 mm
Fuel	unleaded fuel with at least RON 95 (USA = Premium PON 91), mixed with high grade two stroke oil		
Oil / gasoline ratio	1:40		1:60
	when using high grade, two- stroke oil (Motorex Cross Power 2T)		
Crankshaft bearing	1 deep-groove ball bearing / 1 cylinder roller bearing		
Connecting rod bearing	needle bearing		
Piston pin bearing	needle bearing		
Piston	cast piston		
Piston ring	two compression rings		
Dimension „X“ <small>(upper edge piston- upper edge cylinder)</small>	0.0 mm		
Ignition timing	1.4 mm (16.5°) BTDC		
Spark plug	NGK BR9 ECMVX		
Electrode gap	0.60 mm		
Dimension „Z“ <small>(height of the control flap)</small>	43.5 mm	43.1 mm	43.5 mm
Primary drive	straight cut spur gears 23 : 73		
Clutch	multiple disc clutch in oil bath, hydraulically operated (Motorex hydraulic fluid 75)		
Transmission	6 speed, claw actuated		
Gear ratio			
1st gear	13 : 32 „1S32“		12 : 33 „1G33“
2nd gear	„2S15“	15 : 30 „2S30“	„2S15“ 15 : 31 „2G31“
3rd gear	„3S17H“	17 : 28 „3S28H“	„3S17H“ 17 : 28 „3S28H“
4th gear	„4S20H“	20 : 28 „4S28“	„4S19H“ 19 : 26 „4S26“
5th gear	„5S19H“	19 : 23 „5S23“H	„5S21“ 21 : 25 „5S25“
6th gear	„6S22H“	22 : 24 „6S24“H	„6G20“ 20 : 20 „6G20“
Gear lubrication	0,7 liter Motorex Top Speed 4T 15W50		
Available chain sprockets	13t / 14t for chain 5/8 x 1/4"		
Coolant	1.2 litres, 50% anti freeze, 50% distilled water, at least -25 °C (-13 °F)		
Ignition system	KOKUSAN 2K-1		KOKUSAN 2K-3
Carburetor	flat-slide carburetor, carburetor setting see table		
Air-filter	wet foam type air filter insert		

## TECHNICAL SPECIFICATIONS - ENGINE 200 EXC / XC-W / XC 2008

ENGINE	200 EXC	200 XC-W	200 XC
Design	Liquid-cooled, single-cylinder, two-stroke engine with intake and exhaust control		
Piston displacement	193 ccm		
Bore / stroke	64 / 60 mm		
Fuel	unleaded fuel with at least RON 95 (USA = Premium RON 91), mixed with high grade two stroke oil		
Oil / gasoline ratio	1:60 when using high grade, two- stroke oil (Motorex Cross Power 2T).		
Crankshaft bearing	1 deep-groove ball bearing / 1 cylinder roller bearing		
Connecting rod bearing	needle bearing		
Piston pin bearing	needle bearing		
Piston	cast piston		
Piston ring	two compression rings		
Dimension „X“ <small>(upper edge piston- upper edge cylinder)</small>	0,0 mm		
Ignition timing	1.6 mm (17°) BTDC		
Spark plug	NGK BR 8 EG		
Electrode gap	0,60 mm		
Dimension „Z“ <small>(height of the control flap)</small>	48 mm		
Primary drive	straight cut spur gears, primary ratio 23:73		
Clutch	multiple disc clutch in oil bath, hydraulically operated (Motorex hydraulic fluid 75)		
Transmission	6 speed, claw actuated		
Gear ratio			
1st gear	13 : 33 „1G33“		13 : 32 „1S32“
2nd gear	„2S15“	15 : 31 „2G31“	„2S15“ 15 : 30 „2S30“
3rd gear	„3S17H“	17 : 28 „3S28H“	„3S17H“ 17 : 28 „3S28H“
4th gear	„4S19H“	19 : 26 „4S26“	„4S19H“ 19 : 26 „4S26H“
5th gear	„5G17H“	17 : 19 „5G19H“	„5S21“ 21 : 25 „5S25“
6th gear	„6G22H“	22 : 20 „6E20H“	„6G22“ 22 : 23 „6S23“
Gear lubrication	0,7 liter Motorex Top Speed 4T 15W50		
Available chain sprockets	13t / 14t for chain 5/8 x 1/4"		
Coolant	1.2 litres, 50% anti freeze, 50% distilled water, at least -25 °C (-13 °F)		
Ignition system	KOKUSAN 2K-3		
Generator output	12V / 110 W		
Carburetor	flat-slide carburetor, carburetor setting see table		
Air-filter	wet foam type air filter insert		

TIGHTENING TORQUES - ENGINE		
Flange bolts - cylinder-head	M7	18 Nm
Nuts-cylinder base	M8	30 Nm
Flywheel collar nut	M12x1	60 Nm
Nut for primary sprocket	M16x1,5 links	Loctite 243 + 130 Nm
Nut for inner clutch hub	M18x1,5	Loctite 243 + 130 Nm
Collar screws für clutch springs	M6	10 Nm
Collar screw for clutch slave cylinder	M6	Loctite 243 + 10 Nm
Special screw for locating drum shifting	M8	Loctite 243 + 25 Nm
Oil drain plug	M12x1,5	20 Nm
Oil drain plug clutch cover	M10x1	15 Nm
Drain plug for water pump cover	M10x1	15 Nm
Collar screw for water pump cover	M6	Loctite 243 + 10 Nm
Water pump wheel	M5	Loctite 243 + 6 Nm
Crankcase and clutch cover bolts	M6	10 Nm
Collar screws for ignition cover	M5	5 Nm
Collar screws for exhaust flange	M5	6 Nm
Spark plug	M14x1,25	25 Nm
Collar screws for ignition system	M5	Loctite 243 + 6 Nm
Collar screw for kickstarter lever	M8	Loctite 243 + 25 Nm
Collar screw für shifting lever	M6 (10.9)	Loctite 243 + 14 Nm
Other screws	M 5 M 6 M 8 M 10	6 Nm 10 Nm 25 Nm 45 Nm

BASIC CARBURETOR SETTING				
	125 SX	144 SX	125 EXC EU 4,4 KW	125 EXC SIX DAYS
Carburetor: Keihin	PWK 39	PWK 39	PWK 36S AG	PWK 36S AG
Carburetor setting mark	98SA0/1	FJ011	FK0019	FK0070
Main jet	188 (185/190)	202 (200/205)	140 (168/170/172)	170 (168/172)
Idling jet	45 (48)	45 (48)	38x38 (45/48)	45
Starting jet	85	85	50 (85)	85
Jet needle	R1469D (R14DD)	R1471H (R1470H, R1472H)	N84I (NOZE/NOZF)	NOZE (NOZF)
Needle position from top	II	III	V (IV)	IV
Throttle valve	5.5	5.5	7	7
Air adjustment srew open	1.5	1.5	2.5 (1)	1
Performance restrictor	-	-	-	-

BASIC CARBURETOR SETTING			
	200 XC USA 200 XC-W USA 200 EXC YA	200 EXC EU 6 KW	200 EXC AUS
Carburetor: Keihin	PWK 36S AG	PWK 36S AG	PWK 36S AG
Carburetor setting mark	FK0020	FK0021	FK0120
Main jet	162 (160/165)	100 (160/162/165)	162 (160/165)
Idling jet	42	35x35 (42)	35 (42)
Starting jet	85	50 (80)	85
Jet needle	NOZH (NOZG)	N84I	R1475J (NOZG/NOZF)
Needle position from top	IV	IV	III
Throttle valve	7	7	7
Air adjustment srew open	1	1.5 (1)	1
Performance restrictor	-	slide stop 36	slide stop 38

TOLERANCES AND FITTING CLEARANCES		
Piston fitting clearance	125/144 = 0.06 mm	200 = 0.055 mm
Piston ring end cap	max. 0.40 mm	
Connecting rod bearing - radial clearance	0.025-0.035 mm	
Piston pin – radial clearance	0.030 mm	
Transmission shafts end float	0.2-0.4 mm	
Clutch springs - length	new = 40 mm, minimum length = 39 mm	
Clutch discs	min. 2.9 mm (new 3.0 mm)	
Crank stud - run out	0.02 mm	
Crankshaft webs outer dimension	55 mm	

GASKET THICKNESSES	
Crankcase	0.5 mm
Clutch cover	0.5 mm
Clutch driving cylinder	0.3 / 0.5 / 0.75 mm
Cylinder bottom gasket	as required
Available bottom gasket	0.20 / 0.25 / 0.40 / 0.50 / 0.75 mm

PartShark.com  
877-999-5686

## TECHNICAL SPECIFICATIONS - CHASSIS 125 SX / 144 SX 2008

CHASSIS	125 SX	144 SX
Frame	Central chrome-moly-steel frame	
Fork	WP – Up Side Down 4860 MXMA CC (Multi Adjuster Closed Cartridge)	
Wheel travel front/rear	300/335 mm	
Rear suspension	WP PDS 5018 DCC (Progressive Damping System)	
Front brake	Disc brake with carbon-steel brake disc Ø 260 mm, brake caliper floated	
Rear brake	Disc brake with carbon-steel brake disc Ø 220 mm, brake caliper floated	
Brake discs	Wear limit 2.50 mm front / 3.50 mm rear	
Front tires	Bridgestone M59 80/100-21"	Bridgestone M59 80/100-21"
Air pressure offroad	1,0 bar (14 psi)	
Rear tires	Bridgestone M70 100/90-19"	Bridgestone M70 100/90-19"
Air pressure offroad	1,0 bar (14 psi)	
Fuel tank capacity	7.5 liters (1.98 USgal)	
Final drive ratio	13:50 t	14:50 t
Available final sprockets	38t, 40t, 42t, 45t, 48t, 49t, 50t, 51t, 52t	
Chain	5/8 x 1/4 "	
Steering head angle	63°	63°
Wheel base	1471 ± 10 mm	1471 ± 10 mm
Seat height, unloaded	925 mm	
Ground clearance, unloaded	390 mm	390 mm
Weight (without fuel)	90.8 kg	90.8 kg

### STANDARD ADJUSTMENT – FORK

	125/144 SX
	WP 4860 MXMA CC 14.18.7D.01
Compression adjuster	14 clicks
Rebound adjuster	21 clicks
Spring	432.485.00.042W
Fork oil	SAE 5

### STANDARD ADJUSTMENT – SHOCK ABSORBER

	125/144 SX
	WP 5018 PDS DCC 12.18.7D.01
Compression adjuster	
Low speed	14 clicks
High speed	1 turn
Rebound adjuster	23 clicks
Spring	60-250
Spring preload	5 mm



## TECHNICAL SPECIFICATIONS - CHASSIS 125/200 XC/XC-W/EXC/EXC SIX DAYS 2008

CHASSIS	125/200 XC/XC-W/EXC/EXC SIX DAYS
Frame	Central chrome-moly-steel frame
Fork 125/200 XC-W/EXC/EXC Six Days 200 XC	WP Suspension – 4860 MXMA PA (Open Cartridge) WP Suspension – 4860 MXMA CC (Closed Cartridge)
Wheel travel front/rear	300/335 mm
Rear suspension	WP Suspension – 5018 PDS DCC
Front brake	Disc brake with wave carbon-steel brake disc Ø 260 mm (10.2 in), brake caliper floated
Rear brake	Disc brake with wave carbon-steel brake disc Ø 220 mm (8.7 in), brake caliper floated
Brake discs	Wear limit 2.50 mm front / 3.50 mm rear
Front tires * 125/200 EXC/EXC Six Days 200 XC/XC-W	90/90-21 54M Metzeler MCE 6 Days Extreme 80/100-21 51M Bridgestone M59
Air pressure offroad Air pressure road driver only	1,0 bar (14 psi) 1,5 bar (21 psi)
Rear tires * 125/200 EXC/EXC Six Days 200 XC/XC-W	120/90-18 65M Metzeler MCE 6 Days Extreme 100/100-18 59M Bridgestone M402
Air pressure offroad Air pressure road driver only	1,0 bar (14 psi) 2,0 bar (28 psi)
Fuel tank capacity 125 EXC/EXC Six Days, 200 EXC EU 200 XC/XC-W/EXC AUS	9,5 liters (2,5 US gallons), 2 liters (0,52 US gallone) reserve 11 liters (2,9 US gallons) 2 liters (0,52 US gallone) reserve
Final drive ratio 125 EXC EU 125 EXC Six Days 200 XC/XC-W 200 EXC	14:42 13:50 14:48 14:42
Chain	5/8 x 1/4 "
Available final sprockets	38t, 40t, 42t, 45t, 48t, 49t, 50t, 51t, 52t
Bulbs	headlight 12V 35/35W Bilux (base Ba20d) parking light 12V 5W (base W2, 1x9,5d) brake-rear light LED flasher light 12V 10W (base Ba15s)
Steering head angle	63°
Wheel base	1471 ± 10 mm (57.9 in ± 0.4 in)
Seat height, unloaded	925 mm
Ground clearance, unloaded	390 mm
Weight (without fuel) 125/200 EXC/EXC Six Days 200 XC 200 XC-W	97 kg 94,4 kg 94,8 kg

\* further tire releases are available on the Internet at [www.ktm.com](http://www.ktm.com)

STANDARD ADJUSTMENT – FORK			
	125/200 XC-W/EXC	125 EXC Six Days	200 XC
	WP 4860 MXMA PA 14187D02	WP 4860 MXMA PA 14187D33	WP 4860 MXMA CC 14187D27
Compression adjuster	22 clicks	20 clicks	20 clicks
Rebound adjuster	22 clicks	22 clicks	21 clicks
Spring	432.505.00.040W	432.505.00.042W	432.455.00.042W
Preload Adjuster	2 turns	2 turns	–
Air chamber length	110 mm (4,3 in)	110 mm (4,3 in)	–
Fork oil	SAE 5	SAE 5	SAE 5

STANDARD ADJUSTMENT – SHOCK ABSORBER			
	125/200 XC-W/EXC	125 EXC Six Days	200 XC
	WP 5018 PDS DCC 12187D02	WP 5018 PDS DCC 12187D33	WP 5018 PDS DCC 12187D27
Compression adjuster Low Speed	15 clicks	13 clicks	15 clicks
Compression adjuster High Speed	1,5 turns	1,75 turns	1 turn
Rebound adjuster	24 clicks	24 clicks	23 clicks
Spring	66-250	66-250	63-250
Spring preload	7 mm (0,27 in)	7 mm (0,27 in)	5 mm (0,2 in)
Static sag	35 mm ± 2 mm	35 mm ± 2 mm	33 mm ± 2 mm
Riding sag	105 mm ± 5 mm	105 mm ± 5 mm	112 mm ± 5 mm

TIGHTENING TORQUES – CHASSIS		
Collar screw, front wheel spindle	M24x1,5	40 Nm
Brake caliper, front	M8 (10.9)	Loctite 243 + 25 Nm
Brake disks	M6 (10.9)	14 Nm
Screw steering head	M20x1,5	10 Nm
Lower Screw steering head	M20x1,5	Loctite 243 + 60 Nm
Clamping screws, upper fork bridge (machined fork bridge)	M8 (10.9)	17 Nm
Clamping screws, lower fork bridge (machined fork bridge)	M8 (10.9)	12 Nm
Clamping screws, upper steering stem	M8 (10.9)	Loctite 243 + 17 Nm
Clamping screws, upper fork bridge (forged fork bridge)	M8 (10.9)	20 Nm
Clamping screws, lower fork bridge (forged fork bridge)	M8 (10.9)	15 Nm
Clamping screws, fork stubs	M8 (10.9)	15 Nm
Collar nut, rear wheel spindle	M20x1,5	80 Nm
Hexagon nut, swing arm bolt	M16x1,5	100 Nm
Hexagon collar screw, handlebar clamp	M8 (10.9)	20 Nm
Allan head screw, handlebar support	M10 (10.9)	Loctite 243 + 40 Nm
Shock absorber, top	M12 (10.9)	Loctite 243 + 80 Nm
Shock absorber, bottom	M12 (10.9)	Loctite 243 + 80 Nm
Flat-head screws for subframe	M8 (10.9)	Loctite 243 + 35 Nm
Collared nuts for rear sprocket screws	M8 (10.9)	Loctite 243 + 35 Nm
Flat-head screw for side stand	M8 (10.9)	Loctite 243 + 40 Nm
Ball joint for push rod	M6 (10.9)	10 Nm
Engine mounting bolt	M10 (10.9)	60 Nm
Engine brace	M8 (10.9)	33 Nm
Screw adjusting ring spring preload shock absorber	M6	8 Nm
Spoke nipple	M4,5 / M5	5 Nm
Other screws on chassis	M6 M8 M10	10 Nm 25 Nm 45 Nm
Other collar nuts on chassis	M6 M8 M10	15 Nm 30 Nm 50 Nm

## TECHNICAL SPECIFICATIONS - ENGINE 125/150 SX/XC 2009/2010

ENGINE	125 SX	150 SX	150 XC USA
Design	Liquid-cooled, single-cylinder, two-stroke engine with intake and exhaust control		
Piston displacement	124.8 cm <sup>3</sup>	143.6 cm <sup>3</sup>	
Bore / stroke	54/54.5 mm	56/58.4 mm	
Fuel	unleaded fuel with at least RON 95 (USA = Premium PON 91), mixed with high grade two stroke oil		
Oil / gasoline ratio	1 : 40		
	when using high grade, two- stroke oil (Motorex Cross Power 2T)		
Crankshaft bearing	1 deep-groove ball bearing / 1 cylinder roller bearing		
Connecting rod bearing	needle bearing		
Piston pin bearing	needle bearing		
Piston	cast piston		
Piston ring	two compression rings		
Dimension „X“ <small>(upper edge piston- upper edge cylinder)</small>	0.0...0.10 mm		
Ignition timing	1.4 mm BTDC		
Spark plug	NGK BR9 ECMVX		
Electrode gap	0.60 mm		
Dimension „Z“ <small>(height of the control flap)</small>	43.7 mm	44.3 mm	
Primary drive	straight cut spur gears		
Gear ratio	23 : 73		
Clutch	multiple disc clutch in oil bath, hydraulically operated		
	Motorex Hydraulic Fluid 75		
Transmission	6 speed, claw actuated		
Gear ratio			
1st gear	13 : 32 „1S32“	13 : 32 „1S32“	
2nd gear	„2S15“ 15 : 30 „2S30“	„2S15“ 15 : 30 „2S30“	
3rd gear	„3S17H“ 17 : 28 „3S28H“	„3S17H“ 17 : 28 „3S28H“	
4th gear	„4S20H“ 20 : 28 „4S28“	„4S19H“ 19 : 26 „4S26H“	
5th gear	„5S19H“ 19 : 23 „5S23“H	„5S21“ 21 : 25 „5S25“	
6th gear	„6S22H“ 22 : 24 „6S24“H	„6G22“ 22 : 23 „6S23“	
Gear lubrication	0.7 Liter Motorex Top Speed 4T 15W50		
Coolant	1.2 litres, 50% anti freeze, 50% distilled water, at least -25 °C (-13 °F)		
Ignition system	KOKUSAN 2K-1		KOKUSAN 2K-3
Carburetor	flat-slide carburetor, carburetor setting see table		
Air-filter	wet foam type air filter insert		

### BASIC CARBURETOR SETTING

	125 SX	125 SX sandy surfaces	150 SX/XC USA	150 SX sandy surfaces
Carburetor: Keihin	Keihin PWK-S 38 AG		Keihin PWK-S 38 AG	
Carburetor setting mark	AQ7		AQ8	
Main jet	182 (180, 185)	208	182 (180, 185)	208
Idling jet	42 (40, 45)	45	42 (40, 45)	45
Starting jet	85		85	
Starting jet	NOZI (NOZH, NOZJ)	NOZH	NOZI (NOZH, NOZJ)	NOZH
Needle position from top	3	4	2	3
Throttle valve	7		6,5	
Air adjustment srew open	1.5 turns		1.5 turns	

## TECHNICAL SPECIFICATIONS - ENGINE 125/200 EXC/EXC SIX DAYS, 200 XC/XC-W/EXC 2009/2010

ENGINE	125 EXC/EXC SIX DAYS	200 XC-W/EXC	200 XC
Design	Liquid-cooled, single-cylinder, two-stroke engine with intake and exhaust control		
Piston displacement	124.8 ccm	193 ccm	
Bore / stroke	54 / 54.5 mm	64 / 60 mm	
Fuel	unleaded fuel with at least RON 95 (USA = Premium RON 91), mixed with high grade two stroke oil		
Oil / gasoline ratio	1:60 when using high grade, two- stroke oil (Motorex Cross Power 2T). When in doubt, please contact your importer		
Crankshaft bearing	1 deep-groove ball bearing / 1 cylinder roller bearing		
Connecting rod bearing	needle bearing		
Piston pin bearing	needle bearing		
Piston	cast aluminum		
Piston ring	2 half keystone rings	two plain compression rings	
Dimension „X“ <small>(upper edge piston- upper edge cylinder)</small>	0,0 mm +0.10 mm		
Ignition timing	1.4 mm (16.5°) BTDC	1.6 mm (17°) BTDC	
Spark plug	NGK BR9 ECMVX	NGK BR 8 EG	
Electrode gap	0.60 mm		
Dimension „Z“ <small>(height of the control flap)</small>	43.7 mm	47 mm	
Primary drive	straight cut spur gears, primary ratio 23:73		
Clutch	multiple disc clutch in oil bath, hydraulically operated (Motorex hydraulic fluid 75)		
Transmission	6 speed, claw actuated		
Gear ratio			
1st gear	12 : 33 „1G33“	13 : 33 „1G33“	13 : 32 „1S32“
2nd gear	„2S15“ 15 : 31 „2G31“	„2S15“ 15 : 31 „2G31“	„2S15“ 15 : 30 „2S30“
3rd gear	„3S17H“ 17 : 28 „3S28H“	„3S17H“ 17 : 28 „3S28H“	„3S17H“ 17 : 28 „3S28H“
4th gear	„4S19H“ 19 : 26 „4S26“	„4S19H“ 19 : 26 „4S26“	„4S19H“ 19 : 26 „4S26H“
5th gear	„5S21“ 21 : 25 „5S25“	„5G17H“ 17 : 19 „5G19H“	„5S21“ 21 : 25 „5S25“
6th gear	„6G20“ 20 : 20 „6G20“	„6G22H“ 22 : 20 „6E20H“	„6G22“ 22 : 23 „6S23“
Gear lubrication	0,7 liter Motorex Top Speed 4T 15W50		
Available chain sprockets	13t / 14t for chain 5/8 x 1/4"		
Coolant	1.2 litres, 50% anti freeze, 50% distilled water, at least -25 °C (-13 °F)		
Ignition system	KOKUSAN 2K-3		
Generator output	12V / 110 W		
Carburetor	Keihin PWK 36S AG flat-slide carburetor, carburetor setting see table		
Air-filter	wet foam type air filter insert		

### BASIC CARBURETOR SETTING

	125 EXC/EXC SIX DAYS 5 KW	200 XC 200 XC-W	200 EXC AUS	200 EXC EU 7KW
Carburetor	Keihin PWK 36S AG	Keihin PWK 36S AG	Keihin PWK 36S AG	Keihin PWK 36S AG
Carburetor setting mark	FK0191	FK 0200	FK0121	FK0211
Main jet	140 (168/170/172)	162 (160/165)	162 (160/165)	100 (160/162/165)
Idling jet	38x38 (45/48)	42	35 (42)	35X35 (42)
Starting jet	50 (85)	85	85	50 (85)
Jet needle	R84I (NOZE/NOZF)	NOZH (NOZG)	R1475J (NOZG/NOZH)	N84I (NOZG/NOZH)
Needle position from top	5 (4)	4	3	4
Throttle valve	7	7	7	7
Air adjustment srew open	2.5 (1) turns	1 turn	1 turn	1.5 turns (1)
Performance restrictor	-	-	slide stop 36 mm	slide stop 36 mm

TIGHTENING TORQUES - ENGINE		
Flange bolts - cylinder-head	M7	18 Nm
Nuts-cylinder base	M8	30 Nm
Flywheel collar nut	M12x1	60 Nm
Nut for primary sprocket	M16x1,5 links	Loctite 243 + 130 Nm
Nut for inner clutch hub	M18x1,5	Loctite 243 + 130 Nm
Collar screws für clutch springs	M6	10 Nm
Collar screw for clutch slave cylinder	M6	Loctite 243 + 10 Nm
Special screw for locating drum shifting	M8	Loctite 243 + 25 Nm
Oil drain plug	M12x1,5	20 Nm
Oil drain plug clutch cover	M10x1	15 Nm
Drain plug for water pump cover	M10x1	15 Nm
Collar screw for water pump cover	M6	Loctite 243 + 10 Nm
Water pump wheel	M5	Loctite 243 + 6 Nm
Crankcase and clutch cover bolts	M6	10 Nm
Collar screws for ignition cover	M5	5 Nm
Collar screws for exhaust flange	M5	6 Nm
Spark plug	M14x1,25	25 Nm
Collar screws for ignition system	M5	Loctite 243 + 6 Nm
Collar screw for kickstarter lever	M8	Loctite 243 + 25 Nm
Collar screw für shifting lever	M6 (10.9)	Loctite 243 + 14 Nm
Other screws	M 5 M 6 M 8 M 10	6 Nm 10 Nm 25 Nm 45 Nm

## TECHNICAL SPECIFICATIONS - CHASSIS 125/150 SX/XC 2009/2010

CHASSIS	125 SX	150 XC USA	150 SX
Frame	Central chrome-moly-steel frame		
Fork	WP – Up Side Down 4860 MXMA CC (Multi Adjuster Closed Cartridge)		
Wheel travel front/rear	300/335 mm (11.8/13.2 in)		
Rear suspension	WP PDS 5018 DCC (Progressive Damping System)		
Front brake	Disc brake with carbon-steel brake disc Ø 260 mm (10.2 in), brake caliper floated		
Rear brake	Disc brake with carbon-steel brake disc Ø 220 mm (8.7 in), brake caliper floated		
Brake discs	Wear limit 2.50 mm (0.1 in) front / 3.50 mm (0.14 in) rear		
Front tires	Bridgestone M59 80/100-21"		
Air pressure offroad	1.0 bar (14 psi)		
Rear tires	Bridgestone M70 100/90-19"		
Air pressure offroad	1.0 bar (14 psi)		
Fuel tank capacity	8 liters (2.1 USgal)		
Final drive ratio	13:50 t		14:50 t
Available final sprockets	38t, 40t, 42t, 45t, 48t, 49t, 50t, 51t, 52t		
Chain	5/8 x 1/4 "		
Steering head angle	63°		
Wheel base	1471 ± 10 mm (57.9 in ± 0.4 in)		
Seat height, unloaded	985 mm (38.8 in)		
Ground clearance, unloaded	390 mm (15.3 in)		
Weight (without fuel)	90.8 kg	94,4 kg	90.8 kg

### STANDARD ADJUSTMENT – FORK 2009

	125/150 SX
	WP 4860 MXMA CC 14.18.7E.01
Compression adjuster	15 clicks
Rebound adjuster	21 clicks
Fork oil	SAE 5

### STANDARD ADJUSTMENT – FORK 2010

	125/150 SX	150 XC USA
	WP 4860 MXMA CC 14.18.7J.01	14.18.7J.27
Compression adjuster	12 clicks	12 clicks
Rebound adjuster	12 clicks	12 clicks
Fork oil	SAE 5	

### STANDARD ADJUSTMENT – SHOCK ABSORBER 2009

	125/150 SX
	WP 5018 PDS DCC 12.18.7E.01
Compression adjuster	
Low speed	15 clicks
High speed	1 turn
Rebound adjuster	23 clicks
Spring preload	5 mm

### STANDARD ADJUSTMENT – SHOCK ABSORBER 2010

	125/150 SX	150 XC USA
	WP 5018 PDS DCC 12.18.7J.01	12.18.7J.27
Compression adjuster		
Low speed	15 clicks	15 clicks
High speed	1,5 turns	1,5 turns
Rebound adjuster	22 clicks	22 clicks
Spring preload	5 mm	5 mm

**TECHNICAL SPECIFICATIONS - CHASSIS 125/200 XC/XC-W/EXC/EXC SIX DAYS 2009/2010**

CHASSIS	125/200 XC/XC-W/EXC/EXC SIX DAYS
Frame	Central chrome-moly-steel frame
Fork 125/200 XC-W/EXC/EXC Six Days 200 XC	WP Suspension – 4860 MXMA PA (Open Cartridge, Preload Adjuster) WP Suspension – 4860 MXMA CC (Closed Cartridge)
Wheel travel front/rear	300/335 mm (11.8/13.2 in)
Rear suspension	WP Suspension – 5018 PDS DCC (Double Compression Control)
Front brake	Disc brake with wave carbon-steel brake disc Ø 260 mm (10.2 in), brake caliper floated
Rear brake	Disc brake with wave carbon-steel brake disc Ø 220 mm (8.7 in), brake caliper floated
Brake discs	Wear limit 2.50 mm (0.1 in) front / 3.50 mm (0.14 in) rear
Front tires * 125/200 EXC/EXC Six Days 200 XC/XC-W	90/90-21 54M Metzeler MCE 6 Days Extreme 80/100-21 51M Bridgestone M59
Air pressure offroad Air pressure road driver only	1.0 bar (14 psi) 1.5 bar (21 psi)
Rear tires * 125/200 EXC/EXC Six Days 200 XC/XC-W	120/90-18 65M Metzeler MCE 6 Days Extreme 100/100-18 59M Bridgestone M402
Air pressure offroad Air pressure road driver only	1.0 bar (14 psi) 2.0 bar (28 psi)
Fuel tank capacity 125 EXC/EXC Six Days, 200 EXC EU 200 XC/XC-W/EXC AUS	9.5 liters (2.5 US gallons), 2 liters (0.52 US gallon) reserve 11 liters (2.9 US gallons) 2 liters (0.52 US gallon) reserve
Final drive ratio 125 EXC/EXC Six Days 200 XC/XC-W 200 EXC	14:42 14:48 14:42
Chain	5/8 x 1/4 "
Available final sprockets	38t, 40t, 42t, 45t, 48t, 49t, 50t, 51t, 52t
Bulbs	headlight 12V 35/35W Bilux (base Ba20d) parking light 12V 5W (base W2.1x9.5d) brake-rear light LED flasher light 12V 10W (base Ba15s)
Steering head angle	63°
Wheel base	1471 ± 10 mm (57.9 in ± 0.4 in)
Seat height, unloaded	985 mm (38.70 in)
Ground clearance, unloaded	390 mm (15.30 in)
Weight (without fuel) 125/200 EXC/EXC Six Days 200 XC 200 XC-W	97 kg (214 lbs) 94,4 kg (208.4 lbs) 94,8 kg (209.3 lbs)

\* further tire releases are available on the Internet at [www.ktm.com](http://www.ktm.com)

<b>STANDARD ADJUSTMENT – FORK 2009</b>		
	<b>125/200 XC-W/EXC/EXC Six Days</b>	<b>200 XC</b>
	WP 4860 MXMA PA 14187E02	WP 4860 MXMA CC 14187E27
Compression adjuster	22 clicks	15 clicks
Rebound adjuster	22 clicks	21 clicks
Preload Adjuster	2 turns	–
Air chamber length	110 mm (4.3 in)	–
Fork oil	SAE 5	SAE 5

<b>STANDARD ADJUSTMENT – SHOCK ABSORBER 2009</b>		
	<b>125/200 XC-W/EXC/EXC Six Days</b>	<b>200 XC</b>
	WP 5018 PDS DCC 12187E02	WP 5018 PDS DCC 12187E27
Compression adjuster Low Speed	15 clicks	15 clicks
Compression adjuster High Speed	1.5 turns	1 turn
Rebound adjuster	24 clicks	25 clicks
Spring preload	7 mm (0.27 in)	5 mm (0.20 in)
Static sag	35 mm ± 2 mm (1.38 in ± 0.08)	38 mm ± 2 mm (1.50 in ± 0.08)
Riding sag	105 mm ± 5 mm (4.13 in ± 0.20)	112 mm ± 5 mm (4.40 in ± 0.20)

<b>STANDARD ADJUSTMENT – FORK 2010</b>		
	<b>125/200 XC-W/EXC/EXC Six Days</b>	<b>150 XC USA</b>
	WP 4860 MXMA PA 14187J02	WP 4860 MXMA CC 14187J27
Compression adjuster	22 clicks	12 clicks
Rebound adjuster	20 clicks	12 clicks
Preload Adjuster	2 turns	–
Air chamber length	110 mm (4.3 in)	–
Fork oil	SAE 5	SAE 5

<b>STANDARD ADJUSTMENT – SHOCK ABSORBER 2010</b>		
	<b>125/200 XC-W/EXC/EXC Six Days</b>	<b>150 XC USA</b>
	WP 5018 PDS DCC 12187J02	WP 5018 PDS DCC 12187J27
Compression adjuster Low Speed	20 clicks	15 clicks
Compression adjuster High Speed	1.5 turns	1 turn
Rebound adjuster	24 clicks	22 clicks
Spring preload	6 mm (0.27 in)	5 mm (0.20 in)
Static sag	35 mm ± 2 mm (1.38 in ± 0.08)	33 mm ± 2 mm (1.49 in ± 0.08)
Riding sag	105 mm ± 5 mm (4.13 in ± 0.20)	107 mm ± 5 mm (4.25 in ± 0.20)



TIGHTENING TORQUES – CHASSIS		
Collar screw, front wheel spindle	M24x1.5	45 Nm
Brake caliper, front	M8 (10.9)	Loctite 243 + 25 Nm
Brake disks	M6 (10.9)	14 Nm
Screw steering head	M20x1,5	10 Nm
Lower Screw steering head	M20x1,5	Loctite 243 + 60 Nm
Clamping screws, upper fork bridge (machined fork bridge)	M8 (10.9)	17 Nm
Clamping screws, lower fork bridge (machined fork bridge)	M8 (10.9)	12 Nm
Clamping screws, upper steering stem	M8 (10.9)	Loctite 243 + 17 Nm
Clamping screws, upper fork bridge (forged fork bridge)	M8 (10.9)	20 Nm
Clamping screws, lower fork bridge (forged fork bridge)	M8 (10.9)	15 Nm
Clamping screws, fork stubs	M8 (10.9)	15 Nm
Collar nut, rear wheel spindle	M20x1.5	80 Nm
Hexagon nut, swing arm bolt	M16x1.5	100 Nm
Hexagon collar screw, handlebar clamp	M8 (10.9)	20 Nm
Allan head screw, handlebar support	M10 (10.9)	Loctite 243 + 40 Nm
Shock absorber, top	M12 (10.9)	Loctite 243 + 80 Nm
Shock absorber, bottom	M12 (10.9)	Loctite 243 + 80 Nm
Flat-head screws for subframe	M8 (10.9)	Loctite 243 + 35 Nm
Collared nuts for rear sprocket screws	M8 (10.9)	Loctite 243 + 35 Nm
Flat-head screw for side stand	M8 (10.9)	Loctite 243 + 40 Nm
Ball joint for push rod foot brake cylinder	M6 (10.9)	10 Nm
Engine mounting bolt	M10 (10.9)	60 Nm
Engine brace	M8 (10.9)	33 Nm
Screw adjusting ring spring preload shock absorber	M6	8 Nm
Spoke nipple	M4.5 / M5	5 Nm
Other screws on chassis	M6	10 Nm
	M8	25 Nm
	M10	45 Nm
Other collar nuts on chassis	M6	15 Nm
	M8	30 Nm
	M10	50 Nm

**VERGASERREGULIERUNG KEIHN PWK 39**  
**CARBURETOR SETTING KTM 125 SX / MXC / EXC USA '99**

MEERESHÖHE ALTITUDE	TEMPERATUR →	-20°C bis -7°C -2°F to 20°F	-6°C bis 5°C 19°F to 41°F	6°C bis 15°C 42°F to 60°F	16°C bis 24°C 61°F to 78°F	25°C bis 38°C 79°F to 98°F	37°C bis 49°C 99°F to 120°F
3000 m 10000 ft ↑ 2301 m 7501 ft	LSCHR AS LD IJ NADEL NEEDLE POS POS HD MJ	1 1/2 48 NOZH 3 175	1 3/4 45 NOZH 3 172	2 42 NOZH 2 170	2 1/4 40 NOZI 1 168	2 1/2 38 NOZI 1 165	2 3/4 38 NOZI 1 165
2300 m 7500 ft ↑ 1501 m 5001 ft	LSCHR AS LD IJ NADEL NEEDLE POS POS HD MJ	1 1/4 50 NOZG 4 178	1 1/2 48 NOZH 3 175	1 3/4 45 NOZH 3 172	2 42 NOZI 2 170	2 1/4 40 NOZI 1 168	2 1/2 38 NOZI 1 165
1500 m 5000 ft ↑ 751 m 2501 ft	LSCHR AS LD IJ NADEL NEEDLE POS POS HD MJ	1 52 NOZG 4 180	1 1/4 50 NOZG 4 178	1 1/2 48 NOZH 3 175	1 3/4 45 NOZH 3 172	2 42 NOZH 2 170	2 1/4 40 NOZI 1 168
750 m 2500 ft ↑ 301 m 1001 ft	LSCHR AS LD IJ NADEL NEEDLE POS POS HD MJ	3/4 55 NOZG 4 182	1 52 NOZG 4 180	1 1/4 50 NOZH 3 178	1 1/2 48 NOZH 3 175	1 3/4 45 NOZI 3 172	2 42 NOZI 2 170
300 m 1000 ft ↑ Meeresniveau Sea level/	LSCHR AS LD IJ NADEL NEEDLE POS POS HD MJ	1/2 55 NOZF 5 185	3/4 52 NOZG 4 182	1 50 NOZG 4 180	1 1/4 50 NOZH 3 178	1 1/2 48 NOZH 3 175	1 3/4 45 NOZI 2 172

LSCHR = Luftregulierschraube offen  
 LD = Leerlaufdüse  
 POS = Clip Position von oben  
 HD = Hauptdüse

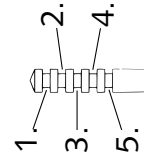

AS = Air screw open from fully-seated  
 IJ = Idling jet  
 POS = Clip position from top  
 MJ = Main jet

**NICHT FÜR STRASSENBETRIEB**

Kraftstoff: Super bleifrei (125:ROZ 98/200:ROZ95)  
 NOT FOR HIGHWAY USE  
 Fuel: Super unleaded (125:ROZ 98/200:ROZ95)

# VERGASERREGULIERUNG KTM 125 SX / EXC EUROPA '99 KEIHIN PWK 39

MEERESHÖHE ALTITUDE	TEMPERATUR →	-20°C bis -7°C -2°F to 20°F	-6°C bis 5°C 19°F to 41°F	6°C bis 15°C 42°F to 60°F	16°C bis 24°C 61°F to 78°F	25°C bis 38°C 79°F to 98°F	37°C bis 49°C 99°F to 120°F
3000 m 10000 ft ↑ 2301 m 7501 ft	AS IJ NEEDLE POS MJ	1 1/2 48 NOZG 3 190	1 3/4 48 NOZH 3 188	1 3/4 45 NOZH 2 185	2 45 NOZH 2 180	2 45 NOZH 2 180	2 1/4 45 NOZH 2 180
2300 m 7500 ft ↑ 1501 m 5001 ft	AS IJ NEEDLE POS MJ	1 1/2 48 NOZF 3 190	1 1/2 48 NOZG 3 190	1 3/4 45 NOZH 2 185	2 45 NOZH 2 182	2 45 NOZH 2 182	2 45 NOZH 2 180
1500 m 5000 ft ↑ 751 m 2501 ft	AS IJ NEEDLE POS MJ	1 1/4 50 NOZF 4 192	1 1/2 48 NOZF 3 190	1 3/4 48 NOZH 3 188	1 3/4 45 NOZH 2 185	1 3/4 45 NOZH 2 185	2 45 NOZH 2 182
750 m 2500 ft ↑ 301 m 1001 ft	AS IJ NEEDLE POS MJ	1 50 NOZF 4 195	1 1/4 50 NOZF 4 192	1 3/4 48 NOZG 3 190	1 3/4 48 NOZG 3 190	1 3/4 48 NOZH 3 188	1 3/4 45 NOZH 2 185
300 m 1000 ft ↑ Meeresniveau Sea level	AS IJ NEEDLE POS MJ	3/4 50 NOZD 4 200	1 50 NOZD 4 198	1 1/2 48 NOZF 3 190	1 1/2 48 NOZF 3 190	1 1/2 48 NOZG 3 190	1 3/4 48 NOZH 2 188

LSCHR = Luftregulierschraube offen  
 LD = Leerlaufdüse  
 POS = Clip Position von oben  
 HD = Hauptdüse

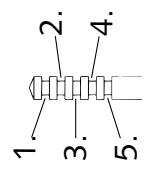

AS = Air screw open from fully-seated  
 IJ = Idling jet  
 POS = Clip position from top  
 MJ = Main jet

**NICHT FÜR STRASSENBETRIEB**  
 Kraftstoff: Euro-Super bleifrei ROZ 98  
 NOT FOR HIGHWAY USE  
 Fuel: Euro-Super unleaded ROZ 98

# VERGASERREGULIERUNG KTM 200 MXC / EXC EUR. USA '99 KEIHIN PWK 39

## CARBURETOR SETTING

MEERESHÖHE ALTITUDE	TEMPERATUR →	-20°C bis -7°C -2°F to 20°F	-6°C bis 5°C 19°F to 41°F	6°C bis 15°C 42°F to 60°F	16°C bis 24°C 61°F to 78°F	25°C bis 38°C 79°F to 98°F	37°C bis 49°C 99°F to 120°F
3000 m 10000 ft ↑ 2301 m 7501 ft	LSCHR AS LD IJ NADEL NEEDLE POS POS HD MJ	1 3/4 45 NOZH 2 180	1 3/4 45 NOZH 2 178	1 3/4 42 NOZI 2 175	2 42 NOZI 1 172	2 42 NOZI 1 170	1 3/4 40 NOZI 1 170
2300 m 7500 ft ↑ 1501 m 5001 ft	LSCHR AS LD IJ NADEL NEEDLE POS POS HD MJ	1 1/4 45 NOZG 3 182	1 3/4 45 NOZH 2 180	1 3/4 45 NOZH 2 178	1 3/4 42 NOZI 2 175	2 42 NOZI 1 172	2 42 NOZI 1 170
1500 m 5000 ft ↑ 751 m 2501 ft	LSCHR AS LD IJ NADEL NEEDLE POS POS HD MJ	1 1/2 48 NOZG 3 182	1 1/4 45 NOZG 3 182	1 1/2 45 NOZH 2 180	1 3/4 45 NOZH 2 178	1 3/4 42 NOZI 2 175	2 42 NOZI 1 172
750 m 2500 ft ↑ 301 m 1001 ft	LSCHR AS LD IJ NADEL NEEDLE POS POS HD MJ	1 1/4 48 NOZG 4 185	1 48 NOZG 3 182	1 1/4 45 NOZG 3 182	1 1/2 45 NOZH 2 180	1 3/4 45 NOZH 2 178	1 3/4 42 NOZI 2 175
300 m 1000 ft ↑ Meeresniveau Sea level	LSCHR AS LD IJ NADEL NEEDLE POS POS HD MJ	1 48 NOZF 4 188	1 1/4 48 NOZG 4 185	1 1/2 48 NOZG 3 182	1 1/4 45 NOZG 3 182	1 1/2 45 NOZH 2 180	1 3/4 45 NOZH 2 178

LSCHR = Luftregulierschraube offen  
LD = Leerlaufdüse  
POS = Clip Position von oben  
HD = Hauptdüse

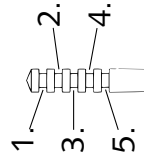

AS = Air screw open from fully-seated  
IJ = Idling jet  
POS = Clip position from top  
MJ = Main jet

### NICHT FÜR STRASSENBETRIEB

Kraftstoff: Super bleifrei (125:ROZ 98/200:ROZ95)  
NOT FOR HIGHWAY USE  
Fuel: Super unleaded (125:ROZ 98/200:ROZ95)

**VERGASERREGULIERUNG CARBURETOR SETTING KTM 125 SX EUROPA / USA 2000 KEIHIN PWK 39**

MEERESHÖHE ALTITUDE	TEMPERATUR →	-20°C bis -7°C -2°F to 20°F	-6°C bis 5°C 19°F to 41°F	6°C bis 15°C 42°F to 60°F	16°C bis 24°C 61°F to 78°F	25°C bis 38°C 79°F to 98°F	37°C bis 49°C 99°F to 120°F
3000 m 10000 ft ↑ 2301 m 7501 ft	LSCHR AS LD IJ NADEL NEEDLE POS POS HD MJ	1 1/2 45 R1468D 2 185	1 3/4 42 R1469D 3 182	2 40 R1469D 2 180	2 1/4 38 R1469D 3 178	2 1/2 38 R1469D 1 175	2 3/4 38 R1469D 1 175
2300 m 7500 ft ↑ 1501 m 5001 ft	LSCHR AS LD IJ NADEL NEEDLE POS POS HD MJ	1 1/4 48 R1468D 3 188	1 1/2 45 R1468D 2 185	1 3/4 42 R1469D 3 182	2 40 R1469D 2 180	2 1/4 38 R1469D 2 178	2 1/2 38 R1469D 1 175
1500 m 5000 ft ↑ 751 m 2501 ft	LSCHR AS LD IJ NADEL NEEDLE POS POS HD MJ	1 50 R1467D 3 190	1 1/4 48 R1468D 3 188	1 1/2 45 R1468D 2 185	1 3/4 42 R1469D 3 182	2 40 R1469D 2 180	2 1/4 38 R1469D 2 178
750 m 2500 ft ↑ 301 m 1001 ft	LSCHR AS LD IJ NADEL NEEDLE POS POS HD MJ	3/4 52 R1467D 4 192	1 3/4 50 R1467D 3 190	1 1/4 48 R1468D 3 188	1 1/2 45 R1468D 2 185	1 3/4 42 R1469D 3 182	2 40 R1469D 2 180
300 m 1000 ft ↑ Meeresniveau Sea level	LSCHR AS LD IJ NADEL NEEDLE POS POS HD MJ	1/2 55 R1467D 5 195	3/4 52 R1467D 4 192	1 1/4 48 R1468D 3 188	1 1/2 45 R1468D 2 185	1 1/2 42 R1468D 3 182	1 3/4 42 R1469D 2 180

LSCHR = Luftregulierschraube offen  
LD = Leerlaufdüse  
POS = Clip Position von oben  
HD = Hauptdüse

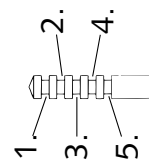

AS = Air screw open from fully-seated  
IJ = Idling jet  
POS = Clip position from top  
MJ = Main jet

**NICHT FÜR STRASSENBETRIEB**  
Kraftstoff: Euro-Super bleifrei ROZ 95  
NOT FOR HIGHWAY USE  
Fuel: Euro-Super unleaded ROZ 95

# VERGASERREGULIERUNG KTM 125 MXC/EXC EUR/USA 2000 KEIHIN PWK 38 AG

## CARBURETOR SETTING

MEERESHÖHE ALTITUDE	TEMPERATUR →	-20°C bis -7°C -2°F to 20°F	-6°C bis 5°C 19°F to 41°F	6°C bis 15°C 42°F to 60°F	16°C bis 24°C 61°F to 78°F	25°C bis 38°C 79°F to 98°F	37°C bis 49°C 99°F to 120°F
3000 m 10000 ft ↑ 2301 m 7501 ft	LSCHR AS LD IJ NADEL NEEDLE POS POS HD MJ	1 1/2 48 NOZH 3 175	1 3/4 45 NOZH 3 172	2 42 NOZH 2 170	2 1/4 40 NOZI 1 168	2 1/2 38 NOZI 1 165	2 3/4 38 NOZI 1 165
2300 m 7500 ft ↑ 1501 m 5001 ft	LSCHR AS LD IJ NADEL NEEDLE POS POS HD MJ	1 1/4 50 NOZG 4 178	1 1/2 48 NOZH 3 175	1 3/4 45 NOZH 3 172	2 42 NOZI 2 170	2 1/4 40 NOZI 1 168	2 1/2 38 NOZI 1 165
1500 m 5000 ft ↑ 751 m 2501 ft	LSCHR AS LD IJ NADEL NEEDLE POS POS HD MJ	1 52 NOZG 4 180	1 1/4 50 NOZG 4 178	1 1/2 48 NOZH 3 175	1 3/4 45 NOZH 3 172	2 42 NOZH 2 170	2 1/4 40 NOZI 1 168
750 m 2500 ft ↑ 301 m 1001 ft	LSCHR AS LD IJ NADEL NEEDLE POS POS HD MJ	3/4 55 NOZG 4 182	1 52 NOZG 4 180	1 1/4 50 NOZH 3 178	1 1/2 48 NOZH 3 175	1 3/4 45 NOZI 3 172	2 42 NOZI 2 170
300 m 1000 ft ↑ Meeresniveau Sea level	LSCHR AS LD IJ NADEL NEEDLE POS POS HD MJ	1/2 55 NOZF 5 185	3/4 52 NOZG 4 182	1 50 NOZG 4 180	1 1/4 50 NOZH 3 178	1 1/2 48 NOZH 3 175	1 3/4 45 NOZI 2 172

LSCHR = Luftregulierschraube offen  
LD = Leerlaufdüse  
POS = Clip Position von oben  
HD = Hauptdüse

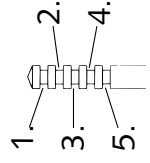

AS = Air screw open from fully-seated  
IJ = Idling jet  
POS = Clip position from top  
MJ = Main jet

NICHT FÜR STRASSENBETRIEB

Kraftstoff: Euro-Super bleifrei ROZ 95  
NOT FOR HIGHWAY USE  
Fuel: Euro-Super unleaded ROZ 95

# VERGASERREGULIERUNG KTM 200 MXC/EXC EUR/USA 2000 KEIHIN PWK 38 AG

## CARBURETOR SETTING

MEERESHÖHE ALTITUDE	TEMPERATUR →	-20°C bis -7°C -2°F to 20°F	-6°C bis 5°C 19°F to 41°F	6°C bis 15°C 42°F to 60°F	16°C bis 24°C 61°F to 78°F	25°C bis 38°C 79°F to 98°F	37°C bis 49°C 99°F to 120°F
3000 m 10000 ft ↑ 2301 m 7501 ft	LSCHR AS	1 3/4	1 3/4	1 3/4	2	2	1 3/4
	LD IJ	45	45	42	42	42	40
	NADEL NEEDLE	NOZH	NOZH	NOZI	NOZI	NOZI	NOZI
	POS POS	2	2	2	1	1	1
	HD MJ	180	178	175	172	170	170
2300 m 7500 ft ↑ 1501 m 5001 ft	LSCHR AS	1 1/4	1 3/4	1 3/4	1 3/4	2	2
	LD IJ	45	45	45	42	42	42
	NADEL NEEDLE	NOZG	NOZH	NOZH	NOZI	NOZI	NOZI
	POS POS	3	2	2	2	1	1
	HD MJ	182	180	178	175	172	170
1500 m 5000 ft ↑ 751 m 2501 ft	LSCHR AS	1 1/2	1 1/4	1 1/2	1 3/4	1 3/4	2
	LD IJ	48	45	45	45	42	42
	NADEL NEEDLE	NOZG	NOZG	NOZH	NOZH	NOZI	NOZI
	POS POS	3	3	2	2	2	1
	HD MJ	182	182	180	178	175	172
750 m 2500 ft ↑ 301 m 1001 ft	LSCHR AS	1 1/4	1	1 1/4	1 1/2	1 3/4	1 3/4
	LD IJ	48	48	45	45	45	42
	NADEL NEEDLE	NOZG	NOZG	NOZG	NOZH	NOZH	NOZI
	POS POS	4	3	3	2	2	2
	HD MJ	185	182	182	180	178	175
300 m 1000 ft ↑ Meeresniveau Sea level	LSCHR AS	1	1 1/4	1 1/2	1 1/4	1 1/2	1 3/4
	LD IJ	48	48	48	45	45	45
	NADEL NEEDLE	NOZF	NOZG	NOZG	NOZH	NOZH	NOZH
	POS POS	4	4	3	2	2	2
	HD MJ	188	185	182	180	178	175

LSCHR = Luftregulierschraube offen  
 LD = Leerlaufdüse  
 POS = Clip Position von oben  
 HD = Hauptdüse

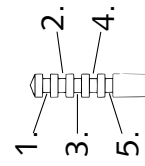

AS = Air screw open from fully-seated  
 IJ = Idling jet  
 POS = Clip position from top  
 MJ = Main jet

**NICHT FÜR STRASSENBETRIEB**  
 Kraftstoff: Euro-Super bleifrei ROZ 95  
 NOT FOR HIGHWAY USE  
 Fuel: Euro-Super unleaded ROZ 95

**VERGASERREGULIERUNG KTM 125 SX EUROPA / USA 2001 KEIHIN PWK 39**  
**CARBURETOR SETTING**

MEERESHÖHE ALTITUDE	TEMPERATUR →	-20°C bis -7°C -2°F to 20°F	-6°C bis 5°C 19°F to 41°F	6°C bis 15°C 42°F to 60°F	16°C bis 24°C 61°F to 78°F	25°C bis 38°C 79°F to 98°F	37°C bis 49°C 99°F to 120°F
3000 m 10000 ft ↑ 2301 m 7501 ft	LSCHR AS LD IJ NADEL NEEDLE POS POS HD MJ	1 1/2 45 R1468D 2 185	1 3/4 42 R1469D 3 182	2 40 R1469D 2 180	2 1/4 38 R1470D 2 178	2 1/2 38 R1470D 1 175	2 3/4 38 R1470D 1 172
2300 m 7500 ft ↑ 1501 m 5001 ft	LSCHR AS LD IJ NADEL NEEDLE POS POS HD MJ	1 1/4 48 R1468D 3 188	1 1/2 45 R1468D 2 185	1 3/4 42 R1469D 3 182	2 40 R1469D 2 180	2 1/4 38 R1469D 2 178	2 1/2 38 R1470D 1 175
1500 m 5000 ft ↑ 751 m 2501 ft	LSCHR AS LD IJ NADEL NEEDLE POS POS HD MJ	1 50 R1467D 3 190	1 1/4 48 R1468D 3 188	1 1/2 45 R1468D 2 185	1 3/4 42 R1469D 2 182	2 40 R1469D 2 180	2 1/4 38 R1469D 2 178
750 m 2500 ft ↑ 301 m 1001 ft	LSCHR AS LD IJ NADEL NEEDLE POS POS HD MJ	3/4 52 R1467D 4 192	1 50 R1467D 3 190	1 1/4 48 R1468D 3 188	1 1/2 45 R1468D 3 185	1 3/4 42 R1469D 2 182	2 40 R1469D 2 180
300 m 1000 ft ↑ Meeresniveau Sea level	LSCHR AS LD IJ NADEL NEEDLE POS POS HD MJ	1/2 55 R1467D 5 195	3/4 52 R1467D 4 192	1 50 R1468D 3 188	1 1/4 48 R1468D 3 185	1 1/2 45 R1469D 2 182	1 3/4 42 R1470D 2 182

LSCHR = Luftregulierschraube offen  
 LD = Leerlaufdüse  
 POS = Clip Position von oben  
 HD = Hauptdüse  
 Schieber = 5,5

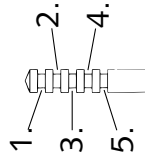

AS = Air screw open from fully-seated

IJ = Idling jet

POS = Clip position from top

MJ = Main jet

Slide = 5,5

**NICHT FÜR STRASSENBETRIEB**

Kraftstoff: Euro-Super bleifrei ROZ 95

NOT FOR HIGHWAY USE

Fuel: Euro-Super unleaded ROZ 95



# VERGASERREGULIERUNG CARBURETOR SETTING **KTM 125 MXC/EXC EUR/USA 2001 KEIHIN PWK 38 AG**

MEERESHÖHE ALTITUDE	TEMPERATUR →	-20°C bis -7°C -2°F to 20°F	-6°C bis 5°C 19°F to 41°F	6°C bis 15°C 42°F to 60°F	16°C bis 24°C 61°F to 78°F	25°C bis 38°C 79°F to 98°F	37°C bis 49°C 99°F to 120°F
3000 m 10000 ft ↑ 2301 m 7501 ft	LSCHR AS	1 1/2	1 3/4	2	2 1/4	2 1/2	2 3/4
	LD IJ	48	45	42	40	38	38
	NADEL NEEDLE	NOZH	NOZH	NOZH	NOZI	NOZI	NOZI
	POS POS	3	3	2	1	1	1
	HD MJ	175	172	170	168	165	165
2300 m 7500 ft ↑ 1501 m 5001 ft	LSCHR AS	1 1/4	1 1/2	1 3/4	2	2 1/4	2 1/2
	LD IJ	50	48	45	42	40	38
	NADEL NEEDLE	NOZG	NOZH	NOZH	NOZI	NOZI	NOZI
	POS POS	4	3	3	2	1	1
	HD MJ	178	175	172	170	168	165
1500 m 5000 ft ↑ 751 m 2501 ft	LSCHR AS	1	1 1/4	1 1/2	1 3/4	2	2 1/4
	LD IJ	52	50	48	45	42	40
	NADEL NEEDLE	NOZG	NOZG	NOZH	NOZH	NOZH	NOZI
	POS POS	4	4	3	2	2	1
	HD MJ	180	178	175	172	170	168
750 m 2500 ft ↑ 301 m 1001 ft	LSCHR AS	3/4	1	1 1/4	1 1/2	1 3/4	2
	LD IJ	55	52	50	48	45	42
	NADEL NEEDLE	NOZG	NOZG	NOZH	NOZH	NOZI	NOZI
	POS POS	4	4	3	3	2	2
	HD MJ	182	180	178	175	172	170
300 m 1000 ft ↑ Meeresniveau Sea level	LSCHR AS	1/2	3/4	1	1 1/4	1 1/2	1 3/4
	LD IJ	55	52	50	50	48	45
	NADEL NEEDLE	NOZF	NOZG	NOZG	NOZH	NOZI	NOZI
	POS POS	5	4	4	3	2	2
	HD MJ	185	182	180	178	175	172

LSCHR = Luftregulierschraube offen  
 LD = Leerlaufdüse  
 POS = Clip Position von oben  
 HD = Hauptdüse  
 Schieber = 6,5

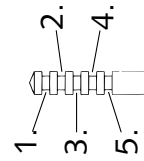

AS = Air screw open from fully-seated  
 IJ = Idling jet  
 POS = Clip position from top  
 MJ = Main jet  
 Slide = 6,5

**NICHT FÜR STRASSENBETRIEB**  
 Kraftstoff: Euro-Super bleifrei ROZ 95  
 NOT FOR HIGHWAY USE  
 Fuel: Euro-Super unleaded ROZ 95

# VERGASERREGULIERUNG KTM 200 MXC/EXC EUR/USA 2001 KEIHIN PWK 38 AG

## CARBURETOR SETTING

MEERESHÖHE ALTITUDE	TEMPERATUR →	-20°C bis -7°C -2°F to 20°F	-6°C bis 5°C 19°F to 41°F	6°C bis 15°C 42°F to 60°F	16°C bis 24°C 61°F to 78°F	25°C bis 38°C 79°F to 98°F	37°C bis 49°C 99°F to 120°F
3000 m 10000 ft ↑ 2301 m 7501 ft	LSCHR AS LD IJ NADEL NEEDLE POS POS HD MJ	1 3/4 45 NOZH 2 180	1 3/4 45 NOZH 2 178	1 3/4 42 NOZI 2 175	2 42 NOZI 1 172	2 42 NOZI 1 170	1 3/4 40 NOZI 1 170
2300 m 7500 ft ↑ 1501 m 5001 ft	LSCHR AS LD IJ NADEL NEEDLE POS POS HD MJ	1 1/4 45 NOZG 3 182	1 3/4 45 NOZH 2 180	1 3/4 45 NOZH 2 178	1 3/4 42 NOZI 2 175	2 42 NOZI 1 172	2 42 NOZI 1 170
1500 m 5000 ft ↑ 751 m 2501 ft	LSCHR AS LD IJ NADEL NEEDLE POS POS HD MJ	1 1/2 48 NOZG 3 182	1 1/4 45 NOZG 3 182	1 1/2 45 NOZH 2 180	1 3/4 45 NOZH 2 178	1 3/4 42 NOZI 2 175	2 42 NOZI 1 172
750 m 2500 ft ↑ 301 m 1001 ft	LSCHR AS LD IJ NADEL NEEDLE POS POS HD MJ	1 1/4 48 NOZF 4 185	1 48 NOZF 4 182	1 1/4 45 NOZG 3 182	1 1/2 45 NOZG 3 180	1 3/4 45 NOZH 2 178	1 3/4 42 NOZI 2 175
300 m 1000 ft ↑ Meeresniveau Sea level	LSCHR AS LD IJ NADEL NEEDLE POS POS HD MJ	1 48 NOZF 5 188	1 1/4 48 NOZF 4 185	1 1/2 48 NOZG 3 182	1 1/4 45 NOZG 3 180	1 1/2 45 NOZH 2 178	1 3/4 45 NOZH 2 178

LSCHR = Luftregulierschraube offen  
LD = Leerlaufdüse  
POS = Clip Position von oben  
HD = Hauptdüse  
Schieber= 6,5

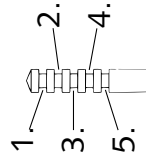

AS = Air screw open from fully-seated  
IJ = Idling jet  
POS = Clip position from top  
MJ = Main jet  
Slide = 6,5

## NICHT FÜR STRASSENBETRIEB

Kraftstoff: Euro-Super bleifrei ROZ 95  
NOT FOR HIGHWAY USE  
Fuel: Euro-Super unleaded ROZ 95

# VERGASERREGULIERUNG CARBURETOR SETTING **KTM 125 SX EUROPA / USA 2002 KEIHIN PWK 39**

MEERESHÖHE ALTITUDE	TEMPERATUR →	-20°C bis -7°C -2°F to 20°F	-6°C bis 5°C 19°F to 41°F	6°C bis 15°C 42°F to 60°F	16°C bis 24°C 61°F to 78°F	25°C bis 38°C 79°F to 98°F	37°C bis 49°C 99°F to 120°F
3000 m 10000 ft ↑ 2301 m 7501 ft	LSCHR AS LD IJ NADEL NEEDLE POS POS HD MJ	1 1/2 45 R1469D 3 185	1 3/4 42 R1470D 3 182	2 40 R1470D 2 180	2 1/4 38 R1470D 2 178	2 1/2 38 R1471D 1 175	2 3/4 38 R1471D 1 172
2300 m 7500 ft ↑ 1501 m 5001 ft	LSCHR AS LD IJ NADEL NEEDLE POS POS HD MJ	1 1/4 48 R1469D 3 188	1 1/2 45 R1469D 3 185	1 3/4 42 R1470D 3 182	2 40 R1470D 2 180	2 1/4 38 R1470D 2 178	2 1/2 38 R1471D 1 175
1500 m 5000 ft ↑ 751 m 2501 ft	LSCHR AS LD IJ NADEL NEEDLE POS POS HD MJ	1 50 R1468D 3 190	1 1/4 48 R1469D 3 188	1 1/2 45 R1469D 2 185	1 3/4 42 R1470D 2 182	2 40 R1470D 2 180	2 1/4 38 R1470D 2 178
750 m 2500 ft ↑ 301 m 1001 ft	LSCHR AS LD IJ NADEL NEEDLE POS POS HD MJ	3/4 52 R1468D 4 192	1 50 R1468D 3 190	1 1/4 48 R1469D 3 188	1 1/2 45 R1469D 3 185	1 3/4 42 R1470D 2 180	2 40 R1470D 2 180
300 m 1000 ft ↑ Meeresniveau Sea level	LSCHR AS LD IJ NADEL NEEDLE POS POS HD MJ	1/2 55 R1468D 5 195	3/4 52 R1468D 4 190	1 1/4 48 R1469D 3 188	1 1/2 45 R1469D 3 185	1 1/2 45 R1469D 2 182	1 3/4 42 R1470D 2 180

LSCHR = Luftregulierschraube offen  
LD = Leerlaufdüse  
POS = Clip Position von oben  
HD = Hauptdüse  
Schieber = 5,5  
Zerstäuber = 6 mm

AS = Air screw open from fully-seated  
IJ = Idling jet  
POS = Clip position from top  
MJ = Main jet  
Slide = 5,5  
Atomizer = 6 mm

**NICHT FÜR STRASSENBETRIEB**  
Kraftstoff: Euro-Super bleifrei ROZ 95  
NOT FOR HIGHWAY USE  
Fuel: Euro-Super unleaded ROZ 95

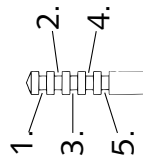

# VERGASERREGULIERUNG KTM 125 EXC EUR 2002 KEIHIN PWK 38 AG

## CARBURETOR SETTING

MEERESHÖHE ALTITUDE	TEMPERATUR →	-20°C bis -7°C -2°F to 20°F	-6°C bis 5°C 19°F to 41°F	6°C bis 15°C 42°F to 60°F	16°C bis 24°C 61°F to 78°F	25°C bis 38°C 79°F to 98°F	37°C bis 49°C 99°F to 120°F
3000 m 10000 ft ↑ 2301 m 7501 ft	LSCHR AS LD IJ NADEL NEEDLE POS POS HD MJ	1 1/2 45 NOZG 3 180	1 3/4 42 NOZG 3 178	2 40 NOZG 2 175	2 1/4 38 NOZH 1 172	2 1/2 35 NOZH 1 170	2 3/4 32 NOZI 1 168
2300 m 7500 ft ↑ 1501 m 5001 ft	LSCHR AS LD IJ NADEL NEEDLE POS POS HD MJ	1 1/4 48 NOZF 4 182	1 1/2 45 NOZG 3 180	1 3/4 42 NOZG 3 178	2 40 NOZH 2 175	2 1/4 38 NOZH 1 172	2 1/2 35 NOZH 1 170
1500 m 5000 ft ↑ 751 m 2501 ft	LSCHR AS LD IJ NADEL NEEDLE POS POS HD MJ	1 50 NOZF 4 185	1 1/4 48 NOZF 4 182	1 1/2 45 NOZG 3 180	1 3/4 42 NOZG 2 178	2 40 NOZG 2 175	2 1/4 38 NOZH 1 172
750 m 2500 ft ↑ 301 m 1001 ft	LSCHR AS LD IJ NADEL NEEDLE POS POS HD MJ	3/4 52 NOZF 4 188	1 50 NOZF 4 185	1 1/4 48 NOZG 3 182	1 1/2 45 NOZG 3 180	1 3/4 42 NOZG 2 178	2 40 NOZH 2 175
300 m 1000 ft ↑ Meeresniveau Sea level	LSCHR AS LD IJ NADEL NEEDLE POS POS HD MJ	1/2 55 NOZE 5 190	3/4 52 NOZF 4 188	1 50 NOZF 4 185	1 1/4 48 NOZG 3 182	1 1/2 45 NOZG 3 180	1 3/4 42 NOZH 2 178

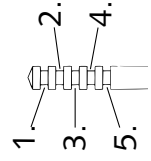

LSCHR = Luftregulierschraube offen  
LD = Leerlaufdüse  
POS = Clip Position von oben  
HD = Hauptdüse  
Schieber = 6,5  
Zerstäuber= 5 mm

AS = Air screw open from fully-seated  
IJ = Idling jet  
POS = Clip position from top  
MJ = Main jet  
Slide = 6,5  
Atomizer= 5 mm

### NICHT FÜR STRASSENBETRIEB

Kraftstoff: Euro-Super bleifrei ROZ 95  
NOT FOR HIGHWAY USE  
Fuel: Euro-Super unleaded ROZ 95

# VERGASERREGULIERUNG KTM 200 MXC/EXC EUR/USA 2002 KEIHIN PWK 38 AG

## CARBURETOR SETTING

MEERESHÖHE ALTITUDE	TEMPERATUR →	-20°C bis -7°C -2°F to 20°F	-6°C bis 5°C 19°F to 41°F	6°C bis 15°C 42°F to 60°F	16°C bis 24°C 61°F to 78°F	25°C bis 38°C 79°F to 98°F	37°C bis 49°C 99°F to 120°F
3000 m 10000 ft ↑ 2301 m 7501 ft	LSCHR AS LD IJ NADEL NEEDLE POS POS HD MJ	1 3/4 45 NOZF 2 178	1 3/4 45 NOZG 2 175	1 3/4 42 NOZH 2 172	2 42 NOZH 1 170	2 42 NOZI 1 168	1 3/4 40 NOZI 1 165
2300 m 7500 ft ↑ 1501 m 5001 ft	LSCHR AS LD IJ NADEL NEEDLE POS POS HD MJ	1 1/4 45 NOZF 3 180	1 3/4 45 NOZF 2 178	1 3/4 45 NOZG 2 175	1 3/4 42 NOZH 2 172	2 42 NOZH 1 170	2 42 NOZI 1 168
1500 m 5000 ft ↑ 751 m 2501 ft	LSCHR AS LD IJ NADEL NEEDLE POS POS HD MJ	1 1/2 48 NOZE 3 182	1 1/4 45 NOZF 3 180	1 1/2 45 NOZF 2 178	1 3/4 45 NOZG 2 175	1 3/4 42 NOZH 2 172	2 42 NOZH 1 170
750 m 2500 ft ↑ 301 m 1001 ft	LSCHR AS LD IJ NADEL NEEDLE POS POS HD MJ	1 1/4 48 NOZD 4 185	1 48 NOZE 4 182	1 1/4 45 NOZF 3 180	1 1/2 45 NOZF 3 178	1 3/4 45 NOZG 2 175	1 3/4 42 NOZH 2 172
300 m 1000 ft ↑ Meeresniveau Sea level	LSCHR AS LD IJ NADEL NEEDLE POS POS HD MJ	1 50 NOZD 5 188	1 1/4 48 NOZD 4 185	1 1/2 48 NOZE 3 182	1 1/4 45 NOZF 3 180	1 1/2 45 NOZF 2 175	1 3/4 45 NOZG 2 172

LSCHR = Luftregulierschraube offen  
LD = Leerlaufdüse  
POS = Clip Position von oben  
HD = Hauptdüse  
Schieber = 6,5  
Zerstäuber = 5 mm

AS = Air screw open from fully-seated  
IJ = Idling jet  
POS = Clip position from top  
MJ = Main jet  
Slide = 6,5  
Atomizer = 5 mm

**NICHT FÜR STRASSEN BETRIEB**  
Kraftstoff: Euro-Super bleifrei ROZ 95  
NOT FOR HIGHWAY USE  
Fuel: Euro-Super unleaded ROZ 95

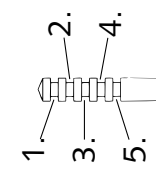

# VERGASERREGULIERUNG / USA 2003 KEIHIN PWK 39

MEERESHÖHE ALTITUDE	TEMPERATUR →	-20°C bis -7°C -2°F to 20°F	-6°C bis 5°C 19°F to 41°F	6°C bis 15°C 42°F to 60°F	16°C bis 24°C 61°F to 78°F	25°C bis 38°C 79°F to 98°F	37°C bis 49°C 99°F to 120°F
3000 m 10000 ft ↑ 2301 m 7501 ft	LSCHR AS LD IJ NADEL NEEDLE POS POS HD MJ	1 1/2 45 R1469D 2 185	1 3/4 42 R1470D 3 182	2 40 R1470D 2 180	2 1/4 38 R1470D 2 178	2 1/2 38 R1471D 1 175	2 3/4 38 R1471D 1 172
2300 m 7500 ft ↑ 1501 m 5001 ft	LSCHR AS LD IJ NADEL NEEDLE POS POS HD MJ	1 1/4 48 R1469D 3 188	1 1/2 45 R1469D 2 185	1 3/4 42 R1470D 3 182	2 40 R1470D 2 180	2 1/4 38 R1470D 2 178	2 1/2 38 R1471D 1 175
1500 m 5000 ft ↑ 751 m 2501 ft	LSCHR AS LD IJ NADEL NEEDLE POS POS HD MJ	1 50 R1468D 3 190	1 1/4 48 R1469D 3 188	1 1/2 45 R1469D 2 185	1 3/4 42 R1470D 2 182	2 40 R1470D 2 180	2 1/4 38 R1470D 2 178
750 m 2500 ft ↑ 301 m 1001 ft	LSCHR AS LD IJ NADEL NEEDLE POS POS HD MJ	3/4 52 R1468D 4 192	1 50 R1468D 3 190	1 1/4 48 R1469D 3 188	1 1/2 45 R1469D 3 185	1 3/4 42 R1470D 2 182	2 40 R1470D 2 180
300 m 1000 ft ↑ Meeresniveau Sea level	LSCHR AS LD IJ NADEL NEEDLE POS POS HD MJ	1/2 55 R1468D 5 195	3/4 52 R1468D 4 192	1 1/4 48 R1469D 3 188	1 1/2 45 R1469D 3 185	1 1/2 45 R141469D 2 185	1 3/4 42 R1470D 2 182

LSCHR = Luftregulierschraube offen

LD = Leerlaufdüse

POS = Clip Position von oben

HD = Hauptdüse

Schieber=5,5

Zerstäuber= 6 mm

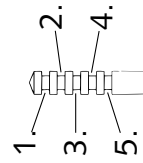

AS = Air screw open from fully-seated

IJ = Idling jet

POS = Clip position from top

MJ = Main jet

Slide = 5,5

Atomizer = 6 mm

## NICHT FÜR STRASSENBETRIEB

Kraftstoff: Euro-Super bleifrei ROZ 95

NOT FOR HIGHWAY USE

Fuel: Euro-Super unleaded ROZ 95

# VERGASERREGULIERUNG KTM 125 EXC EUR 2003 KEIHIN PWK 38 AG CARBURETOR SETTING

MEERESHÖHE ALTITUDE	TEMPERATUR →	-20°C bis -7°C -2°F to 20°F	-6°C bis 5°C 19°F to 41°F	6°C bis 15°C 42°F to 60°F	16°C bis 24°C 61°F to 78°F	25°C bis 38°C 79°F to 98°F	37°C bis 49°C 99°F to 120°F
3000 m 10000 ft ↑ 2301 m 7501 ft	LSCHR AS LD IJ NADEL NEEDLE POS POS HD MJ	1 1/2 45 NOZE 3 3 180	1 3/4 42 NOZE 3 3 178	2 40 NOZE 2 2 175	2 1/4 38 NOZF 1 1 172	2 1/2 35 NOZF 1 1 170	2 3/4 32 NOZG 1 1 168
2300 m 7500 ft ↑ 1501 m 5001 ft	LSCHR AS LD IJ NADEL NEEDLE POS POS HD MJ	1 1/4 48 NOZD 4 4 182	1 1/2 45 NOZE 3 3 180	1 3/4 42 NOZE 3 3 178	2 40 NOZF 2 2 175	2 1/4 38 NOZF 1 1 172	2 1/2 35 NOZF 1 1 170
1500 m 5000 ft ↑ 751 m 2501 ft	LSCHR AS LD IJ NADEL NEEDLE POS POS HD MJ	1 50 NOZD 4 4 185	1 1/4 48 NOZD 4 4 182	1 1/2 45 NOZE 3 3 180	1 3/4 42 NOZE 2 2 178	2 40 NOZE 2 2 175	2 1/4 38 NOZF 1 1 172
750 m 2500 ft ↑ 301 m 1001 ft	LSCHR AS LD IJ NADEL NEEDLE POS POS HD MJ	3/4 52 NOZD 4 4 188	1 3/4 50 NOZD 4 4 185	1 1/4 48 NOZE 3 3 182	1 1/2 45 NOZE 3 3 180	1 3/4 42 NOZE 2 2 175	2 40 NOZF 2 2 172
300 m 1000 ft ↑ Meeresniveau Sea level	LSCHR AS LD IJ NADEL NEEDLE POS POS HD MJ	1/2 55 NOZC 5 5 190	3/4 52 NOZD 4 4 188	1 1/4 48 NOZE 3 3 182	1 1/2 45 NOZE 3 3 180	1 3/4 42 NOZE 2 2 175	2 40 NOZF 2 2 172

LSCHR = Luftregulierschraube offen  
LD = Leerlaufdüse  
POS = Clip Position von oben  
HD = Hauptdüse  
Schieber=6,5  
Zerstäuber= 5 mm

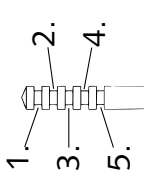

AS = Air screw open from fully-seated  
IJ = Idling jet  
POS = Clip position from top  
MJ = Main jet  
Slide = 6,5  
Atomizer= 5 mm

**NICHT FÜR STRASSENBETRIEB**  
Kraftstoff: Euro-Super bleifrei ROZ 95  
NOT FOR HIGHWAY USE  
Fuel: Euro-Super unleaded ROZ 95

# VERGASERREGULIERUNG KTM 200 SX EUROPA / USA 2003 KEIHIN PWK 39 AG

MEERESHÖHE ALTITUDE	TEMPERATUR →	-20°C bis -7°C -2°F to 20°F	-6°C bis 5°C 19°F to 41°F	6°C bis 15°C 42°F to 60°F	16°C bis 24°C 61°F to 78°F	25°C bis 38°C 79°F to 98°F	37°C bis 49°C 99°F to 120°F
3000 m 10000 ft ↑	LSCHR AS LD IJ NADEL NEEDLE POS POS HD MJ	1 1/2 48 R1468G 2 2 190 188	1 3/4 45 R1469G 3 3 188 188	2 42 R1469G 2 2 185 185	2 1/4 40 R1469G 2 2 182 182	2 1/2 40 R1470G 1 1 180 180	2 3/4 38 R1470G 1 1 178 178
2300 m 7500 ft ↑	LSCHR AS LD IJ NADEL NEEDLE POS POS HD MJ	1 1/4 50 R1468G 3 3 192 192	1 1/2 48 R1468G 2 2 190 190	1 3/4 45 R1469G 3 3 188 188	2 42 R1469G 2 2 185 185	2 1/4 40 R1469G 2 2 182 182	2 1/2 38 R1470G 1 1 180 180
1500 m 5000 ft ↑	LSCHR AS LD IJ NADEL NEEDLE POS POS HD MJ	1 52 R1467G 3 3 195 195	1 1/4 50 R1468G 3 3 192 192	1 1/2 48 R1468G 2 2 190 190	1 3/4 45 R1469G 2 2 188 188	2 42 R1469G 2 2 185 185	2 1/4 4 1469G 2 2 182 182
750 m 2500 ft ↑	LSCHR AS LD IJ NADEL NEEDLE POS POS HD MJ	3/4 55 R1467G 4 4 198 198	1 52 R1467G 3 3 192 192	1 1/4 50 R1468G 3 3 192 192	1 1/2 48 R1468G 3 3 190 190	1 3/4 45 R1469G 2 2 188 188	2 42 R1469G 2 2 185 185
300 m 1000 ft ↑ Meeresniveau Sea level/	LSCHR AS LD IJ NADEL NEEDLE POS POS HD MJ	1/2 58 R1466G 5 5 200 200	3/4 55 R1467G 4 4 198 198	1 1/4 50 R1468G 3 3 192 192	1 1/2 48 R1468G 3 3 190 190	1 3/4 45 R1469G 2 2 188 188	2 42 R1469G 2 2 185 185

LSCHR = Luftregulierschraube offen

LD = Leerlaufdüse

POS = Clip Position von oben

HD = Hauptdüse

Schieber= 5,5

Zerstäuber= 6 mm

AS = Air screw open from fully-seated

IJ = Idling jet

POS = Clip position from top

MJ = Main jet

Slide = 5,5

Atomizer= 6 mm

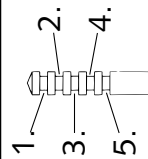

## NICHT FÜR STRASSENBETRIEB

Kraftstoff: Euro-Super bleifrei ROZ 95

NOT FOR HIGHWAY USE

Fuel: Euro-Super unleaded ROZ 95



# VERGASERREGULIERUNG KTM 200 MXC/EXC EUR/USA 2003 KEIHIN PWK 38 AG CARBURETOR SETTING

MEERESHÖHE ALTITUDE	TEMPERATUR →	-20°C bis -7°C -2°F to 20°F	-6°C bis 5°C 19°F to 41°F	6°C bis 15°C 42°F to 60°F	16°C bis 24°C 61°F to 78°F	25°C bis 38°C 79°F to 98°F	37°C bis 49°C 99°F to 120°F
3000 m 10000 ft ↑ 2301 m 7501 ft	LSCHR	1 3/4	1 3/4	1 3/4	2	2	1 3/4
	LD	45	45	42	42	42	40
	NADEL	NOZE	NOZF	NOZG	NOZG	NOZH	NOZH
	POS	2	2	2	1	1	1
	HD	178	175	172	170	168	165
2300 m 7500 ft ↑ 1501 m 5001 ft	LSCHR	1 1/4	1 3/4	1 3/4	1 3/4	2	2
	LD	45	45	45	42	42	42
	NADEL	NOZE	NOZE	NOZF	NOZG	NOZG	NOZH
	POS	3	2	2	2	1	1
	HD	180	178	175	172	170	168
1500 m 5000 ft ↑ 751 m 2501 ft	LSCHR	1 1/2	1 1/4	1 1/2	1 3/4	1 3/4	2
	LD	48	45	45	42	42	42
	NADEL	NOZD	NOZE	NOZE	NOZF	NOZG	NOZG
	POS	3	3	2	2	2	1
	HD	182	180	178	175	172	170
750 m 2500 ft ↑ 301 m 1001 ft	LSCHR	1 1/4	1	1 1/4	1 1/2	1 3/4	1 3/4
	LD	48	48	45	45	45	42
	NADEL	NOZD	NOZD	NOZE	NOZE	NOZF	NOZG
	POS	4	4	3	3	2	2
	HD	185	182	180	178	175	172
300 m 1000 ft ↑ Meeresniveau Sea level	LSCHR	1	1 1/4	1 1/2	1 1/4	1 1/2	1 3/4
	LD	50	48	48	45	45	45
	NADEL	NOZC	NOZD	NOZE	NOZE	NOZF	NOZG
	POS	5	4	3	3	2	2
	HD	188	185	182	180	178	175

LSCHR = Luftregulierschraube offen  
 LD = Leerlaufdüse  
 POS = Clip Position von oben  
 HD = Hauptdüse  
 Schieber=6,5  
 Zerstäuber= 5 mm

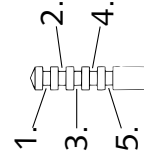

AS = Air screw open from fully-seated  
 IJ = Idling jet  
 POS = Clip position from top  
 MJ = Main jet  
 Slide = 6,5  
**Atomizer= 5 mm**

**NICHT FÜR STRASSENBETRIEB**  
 Kraftstoff: Euro-Super bleifrei ROZ 95  
 NOT FOR HIGHWAY USE  
 Fuel: Euro-Super unleaded ROZ 95

# VERGASERREGULIERUNG CARBURETOR SETTING

## KTM 125 SX EUROPA / USA 2004 KEIHN PWK 39

MEERESHÖHE ALTITUDE	TEMPERATUR →	-20°C bis -7°C -2°F to 20°F	-6°C bis 5°C 19°F to 41°F	6°C bis 15°C 42°F to 60°F	16°C bis 24°C 61°F to 78°F	25°C bis 38°C 79°F to 98°F	37°C bis 49°C 99°F to 120°F
3000 m 10000 ft ↑	LSCHR AS LD IJ NADEL NEEDLE POS POS HD MJ	1 1/2 45 R1469D 2 185	1 3/4 42 R1470D 3 182	2 40 R1470D 2 180	2 1/4 38 R1470D 2 178	2 1/2 38 R1471D 1 175	
2300 m 7500 ft ↑	LSCHR AS LD IJ NADEL NEEDLE POS POS HD MJ	1 1/4 48 R1469D 3 188	1 1/2 45 R1469D 2 185	1 3/4 42 R1470D 3 182	2 40 R1470D 2 180	2 1/4 38 R1470D 2 178	2 1/2 38 R1471D 1 175
1500 m 5000 ft ↑	LSCHR AS LD IJ NADEL NEEDLE POS POS HD MJ	1 50 R1468D 3 190	1 1/4 48 R1469D 3 188	1 1/2 45 R1469D 2 185	1 3/4 42 R1470D 2 182	2 40 R1470D 2 180	2 1/4 38 R1470D 2 178
750 m 2500 ft ↑	LSCHR AS LD IJ NADEL NEEDLE POS POS HD MJ	3/4 52 R1468D 4 192	1 3/4 50 R1468D 3 190	1 1/4 48 R1469D 3 188	1 1/2 45 R1469D 3 185	1 3/4 42 R1470D 2 182	2 40 R1470D 2 180
300 m 1000 ft ↑	LSCHR AS LD IJ NADEL NEEDLE POS POS HD MJ	1/2 55 R1468D 5 195	3/4 52 R1468D 4 192	1 3/4 50 R1468D 3 190	1 1/4 48 R1469D 3 185	1 1/2 45 R1470D 2 182	1 3/4 42 R1470D 2 180
Meersniveau Sea level/	LSCHR AS LD IJ NADEL NEEDLE POS POS HD MJ						

LSCHR = Luftregulierschraube offen  
LD = Leerlaufdüse  
POS = Clip Position von oben  
HD = Hauptdüse  
Schieber = 5,5  
Zerstäuber = 6 mm

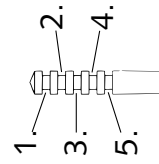

AS = Air screw open from fully-seated  
IJ = Idling jet  
POS = Clip position from top  
MJ = Main jet  
Slide = 5,5  
Atomizer = 6 mm

**NICHT FÜR STRASSENBETRIEB**  
Kraftstoff: Euro-Super bleifrei ROZ 95  
NOT FOR HIGHWAY USE  
Fuel: Euro-Super unleaded ROZ 95

**VERGASERREGULIERUNG  
CARBURETOR SETTING**

**KTM 125 EXC EUR 2004 KEIHING PWK 38 AG**

MEERESHÖHE ALTITUDE	TEMPERATUR →	-20°C bis -7°C -2°F to 20°F	-6°C bis 5°C 19°F to 41°F	6°C bis 15°C 42°F to 60°F	16°C bis 24°C 61°F to 78°F	25°C bis 38°C 79°F to 98°F	37°C bis 49°C 99°F to 120°F
3000 m 10000 ft ↑	AS IJ NEEDLE POS HD	1 1/2 45 NOZE 3 180	1 3/4 42 NOZE 3 178	2 40 NOZE 2 175	2 1/4 38 NOZF 1 172	2 1/2 35 NOZF 1 170	
2300 m 7500 ft ↑	AS IJ NEEDLE POS HD	1 1/4 48 NOZD 4 182	1 1/2 45 NOZE 3 180	1 3/4 42 NOZE 3 178	2 40 NOZF 2 175	2 1/4 38 NOZF 1 172	2 1/2 35 NOZF 1 170
1500 m 5000 ft ↑	AS IJ NEEDLE POS HD	1 50 NOZD 4 185	1 1/4 48 NOZD 4 182	1 1/2 45 NOZE 3 180	1 3/4 42 NOZE 2 178	2 40 NOZE 2 175	2 1/4 38 NOZF 1 172
750 m 2500 ft ↑	AS IJ NEEDLE POS HD	3/4 52 NOZD 4 188	1 50 NOZD 4 185	1 1/4 48 NOZE 3 182	1 1/2 45 NOZE 3 180	1 3/4 42 NOZE 2 178	2 40 NOZF 2 175
300 m 1000 ft ↑ Meeresniveau Sea level/	AS IJ NEEDLE POS HD	1/2 55 NOZC 5 190	3/4 52 NOZD 4 188	1 50 NOZD 4 185	1 1/4 48 NOZE 3 182	1 1/2 45 NOZE 2 178	1 3/4 42 NOZF 2 175

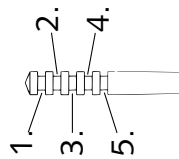

LSCHR = Luftregulierschraube offen  
LD = Leerlaufdüse  
POS = Clip Position von oben  
HD = Hauptdüse  
Schieber = 6,5  
Zerstäuber= 5 mm

AS = Air screw open from fully-seated  
IJ = Idling jet  
POS = Clip position from top  
MJ = Main jet  
Slide = 6,5  
Atomizer= 5 mm

**NICHT FÜR STRASSEN BETRIEB**  
Kraftstoff: Euro-Super bleifrei ROZ 95  
NOT FOR HIGHWAY USE  
Fuel: Euro-Super unleaded ROZ 95

# VERGASERREGULIERUNG CARBURETOR SETTING

## KTM 200 SX EUROPA / USA 2004 KEIHIN PWK 39

MEERESHÖHE ALTITUDE	TEMPERATUR →	-20°C bis -7°C -2°F to 20°F	-6°C bis 5°C 19°F to 41°F	6°C bis 15°C 42°F to 60°F	16°C bis 24°C 61°F to 78°F	25°C bis 38°C 79°F to 98°F	37°C bis 49°C 99°F to 120°F
3000 m 10000 ft ↑ 2301 m 7501 ft	LSCHR AS LD IJ NADEL NEEDLE POS POS HD MJ	1 1/2 48 R1468G 2 2 190	1 3/4 45 R1469G 3 3 188	2 42 R1469G 2 2 185	2 1/4 40 R1469G 2 2 182	2 1/2 40 R1470G 1 1 180	
2300 m 7500 ft ↑ 1501 m 5001 ft	LSCHR AS LD IJ NADEL NEEDLE POS POS HD MJ	1 1/4 50 R1468G 3 3 192	1 1/2 48 R1468G 2 2 190	1 3/4 45 R1469G 3 3 188	2 42 R1469G 2 2 185	2 1/4 40 R1469G 2 2 182	2 1/2 38 R1470G 1 1 180
1500 m 5000 ft ↑ 751 m 2501 ft	LSCHR AS LD IJ NADEL NEEDLE POS POS HD MJ	1 52 R1467G 3 3 195	1 1/4 50 R1468G 3 3 192	1 1/2 48 R1468G 2 2 190	1 3/4 45 R1469G 2 2 188	2 42 R1469G 2 2 185	2 1/4 4 1469G 2 2 182
750 m 2500 ft ↑ 301 m 1001 ft	LSCHR AS LD IJ NADEL NEEDLE POS POS HD MJ	3/4 55 R1467G 4 4 198	1 52 R1467G 3 3 195	1 1/4 50 R1468G 3 3 192	1 1/2 48 R1468G 3 3 190	1 3/4 45 R1469G 2 2 188	2 42 R1469G 2 2 185
300 m 1000 ft ↑ Meeresniveau Sea level	LSCHR AS LD IJ NADEL NEEDLE POS POS HD MJ	1/2 58 R1466G 5 5 200	3/4 55 R1467G 4 4 198	1 52 R1468G 3 3 192	1 1/4 48 R1468G 3 3 190	1 1/2 48 R1468G 2 2 188	1 3/4 45 R1469G 2 2 188

LSCHR = Luftregulierschraube offen

LD = Leerlaufdüse

POS = Clip Position von oben

HD = Hauptdüse

Schieber= 5,5

Zerstäuber= 6 mm

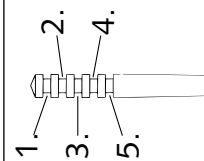

AS = Air screw open from fully-seated

IJ = Idling jet

POS = Clip position from top

MJ = Main jet

Slide = 5,5

Atomizer= 6 mm

**NICHT FÜR STRASSENBETRIEB**

Kraftstoff: Euro-Super bleifrei ROZ 95

NOT FOR HIGHWAY USE

Fuel: Euro-Super unleaded ROZ 95

**VERGASERREGULIERUNG  
CARBURETOR SETTING**

**KTM 200 EXC EUR/USA 2004 KEIHIN PWK 38 AG**

MEERESHÖHE ALTITUDE	TEMPERATUR →	-20°C bis -7°C -2°F to 20°F	-6°C bis 5°C 19°F to 41°F	6°C bis 15°C 42°F to 60°F	16°C bis 24°C 61°F to 78°F	25°C bis 38°C 79°F to 98°F	37°C bis 49°C 99°F to 120°F
3000 m 10000 ft ↑ 2301 m 7501 ft	LSCHR AS LD IJ NADEL NEEDLE POS POS HD MJ	1 3/4 45 NOZE 2 178	1 3/4 45 NOZF 2 175	1 3/4 42 NOZG 2 172	2 42 NOZG 1 170	2 42 NOZH 1 168	
2300 m 7500 ft ↑ 1501 m 5001 ft	LSCHR AS LD IJ NADEL NEEDLE POS POS HD MJ	1 1/4 45 NOZE 3 180	1 3/4 45 NOZE 2 178	1 3/4 45 NOZF 2 175	1 3/4 42 NOZG 2 172	2 42 NOZG 1 170	2 42 NOZH 1 168
1500 m 5000 ft ↑ 751 m 2501 ft	LSCHR AS LD IJ NADEL NEEDLE POS POS HD MJ	1 1/2 48 NOZD 3 182	1 1/4 45 NOZE 3 180	1 1/2 45 NOZE 2 178	1 3/4 45 NOZF 2 175	1 3/4 42 NOZG 2 172	2 42 NOZG 1 170
750 m 2500 ft ↑ 301 m 1001 ft	LSCHR AS LD IJ NADEL NEEDLE POS POS HD MJ	1 1/4 48 NOZD 4 185	1 48 NOZD 4 182	1 1/4 45 NOZE 3 180	1 1/2 45 NOZE 3 178	1 3/4 45 NOZF 2 175	1 3/4 42 NOZG 2 172
300 m 1000 ft ↑ Meeresniveau Sea level	LSCHR AS LD IJ NADEL NEEDLE POS POS HD MJ	1 50 NOZC 5 188	1 1/4 48 NOZD 4 185	1 1/2 48 NOZD 3 182	1 1/4 45 NOZE 3 180	1 1/2 45 NOZE 2 175	1 3/4 45 NOZG 2 172

LSCHR = Luftregulierschraube offen  
LD = Leerlaufdüse  
POS = Clip Position von oben  
HD = Hauptdüse  
Schieber = 6,5  
Zerstäuber= 5 mm

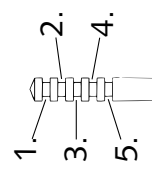

AS = Air screw open from fully-seated  
IJ = Idling jet  
POS = Clip position from top  
MJ = Main jet  
Slide = 6,5  
Atomizer= 5 mm

**NICHT FÜR STRASSENBETRIEB**  
Kraftstoff: Euro-Super bleifrei ROZ 95  
NOT FOR HIGHWAY USE  
Fuel: Euro-Super unleaded ROZ 95

VERGASERREGULIERUNG CARBURETOR SETTING KEIHIN PWK 39		125 SX 2005						
MEERESHÖHE ALTITUDE ↓	TEMPERATUR TEMPERATURE →	-20°C bis -7°C -2°F to 20°F	-6°C bis 5°C 19°F to 41°F	6°C bis 15°C 42°F to 60°F	16°C bis 24°C 61°F to 78°F	25°C bis 38°C 79°F to 98°F	37°C bis 49°C 99°F to 120°F	
3000 m 10000 ft ↑ 2301 m 7501 ft	LSO ASO LD IJ NADEL NEEDLE POS POS HD MJ	1,5 45 R1469D 2 185	1,75 42 R1470D 3 182	2 40 R1470D 2 180	2,25 38 R1470D 2 178	2,5 38 R1471D 1 175		
2300 m 7500 ft ↑ 1501 m 5001 ft	LSO ASO LD IJ NADEL NEEDLE POS POS HD MJ	1,25 48 R1469D 3 188	1,5 45 R1469D 2 185	1,75 42 R1470D 3 182	2 40 R1470D 2 180	2,25 38 R1470D 2 178	2,5 38 R1471D 1 175	
1500 m 5000 ft ↑ 751 m 2501 ft	LSO ASO LD IJ NADEL NEEDLE POS POS HD MJ	1 50 R1468D 3 190	1,25 48 R1469D 3 188	1,5 45 R1469D 2 185	1,75 42 R1470D 2 182	2 40 R1470D 2 180	2,25 38 R1470D 2 178	
750 m 2500 ft ↑ 301 m 1001 ft	LSO ASO LD IJ NADEL NEEDLE POS POS HD MJ	0,75 52 R1468D 4 192	1 50 R1468D 3 190	1,25 48 R1469D 3 188	1,5 45 R1469D 2 188	1,75 42 R1470D 2 182	2 40 R1470D 2 180	
300 m 1000 ft ↑ Meeresniveau Sea level	LSO ASO LD IJ NADEL NEEDLE POS POS HD MJ	0,5 55 R1468D 5 195	0,75 52 R1468D 4 192	1 50 R1469D 3 190	1,25 48 R1469D 3 188	1,5 45 R1469D 2 185	1,75 42 R1470D 2 182	

LSO = Luftregulierschraube offen  
LD = Leerlaufdüse  
POS = Nadel Clip Position von oben  
HD = Hauptdüse

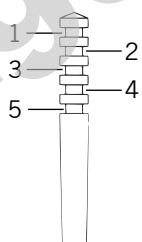

ASO = Air screw open from fully-seated  
IJ = Idling jet  
POS = Needle clip position from top  
MJ = Main jet

#### NICHT FÜR STRASSEN BETRIEB

Kraftstoff: Super Bleifrei ROZ 95

#### NOT FOR HIGHWAY USE

Fuel: unleaded fuel with at least RON 95

USA = Premium PON 91

VERGASERREGULIERUNG CARBURETOR SETTING KEIHIN PWK 38 AG		125 EXC 2005						
MEERESHÖHE ALTITUDE ↓	TEMPERATUR TEMPERATURE →	-20°C bis -7°C	-6°C bis 5°C	6°C bis 15°C	16°C bis 24°C	25°C bis 38°C	37°C bis 49°C	
		-2°F to 20°F	19°F to 41°F	42°F to 60°F	61°F to 78°F	79°F to 98°F	99°F to 120°F	
3000 m 10000 ft ↑ 2301 m 7501 ft	LSO ASO LD IJ NADEL NEEDLE POS POS HD MJ	1,5 45 NOZE 4 180	1,75 42 NOZE 4 178	2 40 NOZE 3 175	2,25 38 NOZF 2 172	2,5 35 NOZF 2 170		
2300 m 7500 ft ↑ 1501 m 5001 ft	LSO ASO LD IJ NADEL NEEDLE POS POS HD MJ	1,25 48 NOZD 5 182	1,5 45 NOZE 4 180	1,75 42 NOZE 4 178	2 40 NOZF 3 175	2,25 38 NOZF 2 172	2,5 35 NOZF 2 170	
1500 m 5000 ft ↑ 751 m 2501 ft	LSO ASO LD IJ NADEL NEEDLE POS POS HD MJ	1 50 NOZD 5 185	1,25 48 NOZD 5 182	1,5 45 NOZE 4 180	1,75 42 NOZE 3 178	2 40 NOZE 3 175	2,25 38 NOZF 2 172	
750 m 2500 ft ↑ 301 m 1001 ft	LSO ASO LD IJ NADEL NEEDLE POS POS HD MJ	0,75 52 NOZD 5 188	1 50 NOZD 5 185	1,25 48 NOZE 4 182	1,5 45 NOZE 4 180	1,75 42 NOZE 3 178	2 40 NOZF 3 175	
300 m 1000 ft ↑ Meeresniveau Sea level	LSO ASO LD IJ NADEL NEEDLE POS POS HD MJ	0,5 55 NOZC 5 190	0,75 52 NOZD 5 188	1 50 NOZD 5 185	1,25 48 NOZE 4 182	1,5 45 NOZE 4 180	1,75 42 NOZF 3 178	

Art.-Nr. 3.206.062-E

LSO = Luftregulierschraube offen  
LD = Leerlaufdüse  
POS = Nadel Clip Position von oben  
HD = Hauptdüse

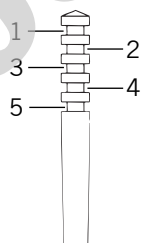

ASO = Air screw open from fully-seated  
IJ = Idling jet  
POS = Needle clip position from top  
MJ = Main jet

**NICHT FÜR STRASSENBETRIEB**  
Kraftstoff: Super Bleifrei ROZ 95

**NOT FOR HIGHWAY USE**  
Fuel: unleaded fuel with at least RON 95  
USA = Premium PON 91

Repair manual KTM 125 / 200

**EXC models:** The carburetor adjustments described above only apply to dethrottled motorcycles. Other measures will be required in addition to the carburetor adjustment for full engine performance. Your KTM dealer will be pleased to assist you.  
**CHANGES TO YOUR MOTORCYCLE WILL CAUSE YOU TO LOSE YOUR ROAD APPROVAL. IT WILL BE ILLEGAL TO OPERATE THE MOTORCYCLE ON PUBLIC ROADS! YOUR INSURANCE COVERAGE WILL ALSO BE CANCELLED!**

VERGASERREGULIERUNG CARBURETOR SETTING KEIHIN PWK 38 AG		200 EXC 2005						
MEERESHÖHE ALTITUDE ↓	TEMPERATUR TEMPERATURE →	-20°C bis -7°C	-6°C bis 5°C	6°C bis 15°C	16°C bis 24°C	25°C bis 38°C	37°C bis 49°C	
		-2°F to 20°F	19°F to 41°F	42°F to 60°F	61°F to 78°F	79°F to 98°F	99°F to 120°F	
3000 m 10000 ft ↑	LSO ASO LD IJ NADEL NEEDLE POS POS HD MJ	1,75 45 NOZE 2 178	1,75 45 NOZF 2 175	1,75 42 NOZG 2 172	2 42 NOZG 1 170	2 42 NOZH 1 168		
2300 m 7500 ft ↑	LSO ASO LD IJ NADEL NEEDLE POS POS HD MJ	1,25 45 NOZE 3 180	1,75 45 NOZE 2 178	1,75 45 NOZF 2 175	1,75 42 NOZG 2 172	2 42 NOZG 1 170	2 42 NOZH 1 168	
1500 m 5000 ft ↑	LSO ASO LD IJ NADEL NEEDLE POS POS HD MJ	1,5 48 NOZD 3 182	1,25 45 NOZE 3 180	1,5 45 NOZE 2 178	1,75 45 NOZF 2 175	1,75 42 NOZG 2 172	2 42 NOZG 1 170	
750 m 2500 ft ↑	LSO ASO LD IJ NADEL NEEDLE POS POS HD MJ	1,25 48 NOZD 4 185	1 48 NOZD 4 182	1,25 45 NOZE 3 180	1,5 45 NOZE 3 178	1,75 45 NOZF 2 175	1,75 42 NOZG 2 172	
300 m 1000 ft ↑ Meeresniveau Sea level	LSO ASO LD IJ NADEL NEEDLE POS POS HD MJ	1 50 NOZC 5 188	1,25 48 NOZD 4 185	1,5 48 NOZD 3 182	1,25 45 NOZE 3 180	1,5 45 NOZE 2 178	1,75 45 NOZG 2 175	

LSO = Luftregulierschraube offen  
LD = Leerlaufdüse  
POS = Nadel Clip Position von oben  
HD = Hauptdüse

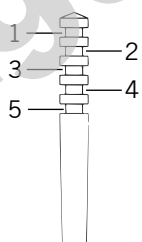

ASO = Air screw open from fully-seated  
IJ = Idling jet  
POS = Needle clip position from top  
MJ = Main jet

#### NICHT FÜR STRASSEN BETRIEB

Kraftstoff: Super Bleifrei ROZ 95

#### NOT FOR HIGHWAY USE

Fuel: unleaded fuel with at least RON 95

USA = Premium PON 91

**EXC models:** The carburetor adjustments described above only apply to dethrottled motorcycles. Other measures will be required in addition to the carburetor adjustment for full engine performance. Your KTM dealer will be pleased to assist you.

**CHANGES TO YOUR MOTORCYCLE WILL CAUSE YOU TO LOSE YOUR ROAD APPROVAL. IT WILL BE ILLEGAL TO OPERATE THE MOTORCYCLE ON PUBLIC ROADS! YOUR INSURANCE COVERAGE WILL ALSO BE CANCELLED!**



VERGASERREGULIERUNG CARBURETOR SETTING KEIHIN PWK 36S AG		125 EXC / EXC SIX DAYS 2006						
MEERESHÖHE ALTITUDE ↓	TEMPERATUR TEMPERATURE →	-20°C bis -7°C -2°F to 20°F	-6°C bis 5°C 19°F to 41°F	6°C bis 15°C 42°F to 60°F	16°C bis 24°C 61°F to 78°F	25°C bis 36°C 79°F to 98°F	37°C bis 49°C 99°F to 120°F	
3000 m 10000 ft ↑	LSO ASO LD IJ NADEL NEEDLE POS POS HD MJ	1 45 NOZE 4 170	1,5 45 NOZE 3 168	1,5 42 NOZF 3 165	2 40 NOZF 2 162	2 38 NOZG 2 170		
2300 m 7500 ft ↑	LSO ASO LD IJ NADEL NEEDLE POS POS HD MJ	1 48 NOZE 4 170	1 45 NOZE 4 170	1,5 45 NOZE 3 168	1,5 42 NOZF 3 165	2 40 NOZF 2 162	2 38 NOZG 2 160	
1500 m 5000 ft ↑	LSO ASO LD IJ NADEL NEEDLE POS POS HD MJ	0,75 48 NOZD 4 172	1 48 NOZE 4 170	1 45 NOZE 4 170	1,5 45 NOZE 3 168	1,5 42 NOZF 3 165	2 40 NOZF 2 162	
750 m 2500 ft ↑	LSO ASO LD IJ NADEL NEEDLE POS POS HD MJ	0,75 50 NOZD 5 175	0,75 48 NOZD 4 172	1 48 NOZE 4 170	1 45 NOZE 4 170	1,5 45 NOZE 3 168	1,5 42 NOZF 3 165	
300 m 1000 ft ↑ Meeresniveau Sea level	LSO ASO LD IJ NADEL NEEDLE POS POS HD MJ	0,75 52 NOZC 5 178	0,75 50 NOZD 5 175	0,75 48 NOZD 4 172	1 48 NOZE 4 170	1 45 NOZE 4 170	1,5 45 NOZE 3 168	

Art.-Nr. 3.206.062-E

LSO = Luftregulierschraube offen  
LD = Leerlaufdüse  
POS = Nadel Clip Position von oben  
HD = Hauptdüse

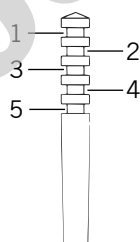

ASO = Air screw open from fully-seated  
IJ = Idling jet  
POS = Needle clip position from top  
MJ = Main jet

**NICHT FÜR STRASSEN BETRIEB**

Kraftstoff: Super Bleifrei ROZ 95

**NOT FOR HIGHWAY USE**

Fuel: unleaded fuel with at least RON 95  
USA = Premium PON 91

**EXC models:** The carburetor adjustments described above only apply to de-throttled motorcycles. Other measures will be required in addition to the carburetor adjustment for full engine performance. Your KTM dealer will be pleased to assist you.

**CHANGES TO YOUR MOTORCYCLE WILL CAUSE YOU TO LOSE YOUR ROAD APPROVAL. IT WILL BE ILLEGAL TO OPERATE THE MOTORCYCLE ON PUBLIC ROADS! YOUR INSURANCE COVERAGE WILL ALSO BE CANCELLED!**

VERGASERREGULIERUNG CARBURETOR SETTING KEIHIN PWK 39		125 SX / SXS 2006						
MEERESHÖHE ALTITUDE ↓	TEMPERATUR TEMPERATURE →	-20°C bis -7°C -2°F to 20°F	-6°C bis 5°C 19°F to 41°F	6°C bis 15°C 42°F to 60°F	16°C bis 24°C 61°F to 78°F	25°C bis 38°C 79°F to 98°F	37°C bis 49°C 99°F to 120°F	
3000 m 10000 ft ↑ 2301 m 7501 ft	LSO ASO LD IJ NADEL NEEDLE POS POS HD MJ	1,5 45 R1469D 2 185	1,75 42 R1470D 3 182	2 40 R1470D 2 180	2,25 38 R1470D 2 178	2,5 38 R1471D 1 175		
2300 m 7500 ft ↑ 1501 m 5001 ft	LSO ASO LD IJ NADEL NEEDLE POS POS HD MJ	1,25 48 R1469D 3 188	1,5 45 R1469D 2 185	1,75 42 R1470D 3 182	2 40 R1470D 2 180	2,25 38 R1470D 2 178	2,5 38 R1471D 1 175	
1500 m 5000 ft ↑ 751 m 2501 ft	LSO ASO LD IJ NADEL NEEDLE POS POS HD MJ	1 50 R1468D 3 190	1,25 48 R1469D 3 188	1,5 45 R1469D 2 185	1,75 42 R1470D 2 182	2 40 R1470D 2 180	2,25 38 R1470D 2 178	
750 m 2500 ft ↑ 301 m 1001 ft	LSO ASO LD IJ NADEL NEEDLE POS POS HD MJ	0,75 52 R1468D 4 192	1 50 R1468D 3 190	1,25 48 R1469D 3 188	1,5 45 R1469D 2 188	1,75 42 R1470D 2 182	2 40 R1470D 2 180	
300 m 1000 ft ↑ Meeresniveau Sea level	LSO ASO LD IJ NADEL NEEDLE POS POS HD MJ	0,5 55 R1468D 5 195	0,75 52 R1468D 4 192	1 50 R1469D 3 190	1,25 48 R1469D 3 188	1,5 45 R1469D 2 185	1,75 42 R1470D 2 182	

LSO = Luftregulierschraube offen  
LD = Leerlaufdüse  
POS = Nadel Clip Position von oben  
HD = Hauptdüse

**NICHT FÜR STRASSEN BETRIEB**

Kraftstoff: Super Bleifrei ROZ 95/98

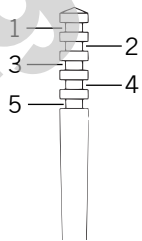

ASO = Air screw open from fully-seated  
IJ = Idling jet  
POS = Needle clip position from top  
MJ = Main jet

**NOT FOR HIGHWAY USE**

Fuel: unleaded fuel with at least RON 95/98  
USA = Premium PON 91/94

VERGASERREGULIERUNG CARBURETOR SETTING KEIHIN PWK 38 AG		200 EXC / XC-W / XC 2006						
MEERESHÖHE ALTITUDE ↓	TEMPERATUR TEMPERATURE →	-20°C bis -7°C	-6°C bis 5°C	6°C bis 15°C	16°C bis 24°C	25°C bis 36°C	37°C bis 49°C	
		-2°F to 20°F	19°F to 41°F	42°F to 60°F	61°F to 78°F	79°F to 98°F	99°F to 120°F	
3000 m 10000 ft ↑	LSO ASO LD IJ NADEL NEEDLE POS POS HD MJ	1,5 45 NOZE 3 172	1,5 42 NOZF 2 170	1,5 42 NOZG 2 168	2 40 NOZG 1 165	2 40 NOZH 1 162		
2300 m 7500 ft ↑	LSO ASO LD IJ NADEL NEEDLE POS POS HD MJ	1,5 45 NOZE 3 175	1,5 45 NOZE 3 172	1,5 42 NOZF 2 170	1,5 42 NOZG 2 168	2 40 NOZG 1 165	2 40 NOZH 1 162	
1500 m 5000 ft ↑	LSO ASO LD IJ NADEL NEEDLE POS POS HD MJ	1,5 48 NOZE 4 178	1,5 45 NOZE 3 175	1,5 45 NOZE 3 172	1,5 42 NOZF 2 170	1,5 42 NOZG 2 168	2 40 NOZG 1 165	
750 m 2500 ft ↑	LSO ASO LD IJ NADEL NEEDLE POS POS HD MJ	1 48 NOZD 4 180	1,5 48 NOZE 4 178	1,5 45 NOZE 3 175	1,5 45 NOZE 3 172	1,5 42 NOZF 2 170	1,5 42 NOZG 2 168	
300 m 1000 ft ↑ Meeresniveau Sea level	LSO ASO LD IJ NADEL NEEDLE POS POS HD MJ	1 50 NOZD 5 182	1 48 NOZD 4 180	1,5 48 NOZE 4 178	1,5 45 NOZE 3 175	1,5 45 NOZE 3 172	1,5 42 NOZF 2 170	

Art.-Nr. 3.206.062-E

LSO = Luftregulierschraube offen  
LD = Leerlaufdüse  
POS = Nadel Clip Position von oben  
HD = Hauptdüse

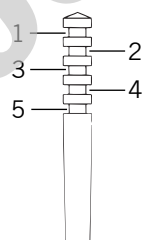

ASO = Air screw open from fully-seated  
IJ = Idling jet  
POS = Needle clip position from top  
MJ = Main jet

**NICHT FÜR STRASSEN BETRIEB**

Kraftstoff: Super Bleifrei ROZ 95

**NOT FOR HIGHWAY USE**

Fuel: unleaded fuel with at least RON 95  
USA = Premium PON 91

**EXC models:** The carburetor adjustments described above only apply to dehorned motorcycles. Other measures will be required in addition to the carburetor adjustment for full engine performance. Your KTM dealer will be pleased to assist you.

**CHANGES TO YOUR MOTORCYCLE WILL CAUSE YOU TO LOSE YOUR ROAD APPROVAL. IT WILL BE ILLEGAL TO OPERATE THE MOTORCYCLE ON PUBLIC ROADS! YOUR INSURANCE COVERAGE WILL ALSO BE CANCELLED!**

VERGASERREGULIERUNG CARBURETOR SETTING KEIHIN PWK 39		125 SX / SXS 2007						
MEERESHÖHE ALTITUDE ↓	TEMPERATUR TEMPERATURE →	-20°C bis -7°C -2°F to 20°F	-6°C bis 5°C 19°F to 41°F	6°C bis 15°C 42°F to 60°F	16°C bis 24°C 61°F to 78°F	25°C bis 36°C 79°F to 98°F	37°C bis 49°C 99°F to 120°F	
3000 m 10000 ft ↑ 2301 m 7501 ft	LSO ASO LD IJ NADEL NEEDLE POS POS HD MJ	1,5 45 R1469D 2 188	1,75 45 R1470D 2 185	2 42 R1470D 2 182	2,25 40 R1470D 2 180	2,5 38 R1471D 1 178		
2300 m 7500 ft ↑ 1501 m 5001 ft	LSO ASO LD IJ NADEL NEEDLE POS POS HD MJ	1,5 48 R1469D 2 190	1,5 45 R1469D 2 188	1,75 45 R1470D 2 185	2 42 R1470D 2 182	2,25 40 R1470D 2 180	2,5 38 R1471D 1 178	
1500 m 5000 ft ↑ 751 m 2501 ft	LSO ASO LD IJ NADEL NEEDLE POS POS HD MJ	1 48 R1468D 3 192	1,5 48 R1469D 2 190	1,5 45 R1469D 2 188	1,75 45 R1470D 2 185	2 42 R1470D 2 182	2,25 40 R1470D 2 180	
750 m 2500 ft ↑ 301 m 1001 ft	LSO ASO LD IJ NADEL NEEDLE POS POS HD MJ	1 50 R1468D 3 195	1 48 R1468D 3 192	1,5 48 R1469D 2 190	1,5 45 R1469D 2 188	1,75 45 R1470D 2 185	2 42 R1470D 2 182	
300 m 1000 ft ↑ Meeresniveau Sea level	LSO ASO LD IJ NADEL NEEDLE POS POS HD MJ	0,75 52 R1468D 4 198	1 50 R1468D 3 195	1 48 R1468D 3 192	1,5 48 R1469D 2 190	1,5 45 R1469D 2 188	1,75 45 R1470D 2 185	

LSO = Luftregulierschraube offen  
LD = Leerlaufdüse  
POS = Nadel Clip Position von oben  
HD = Hauptdüse

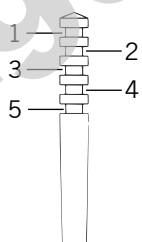

ASO = Air screw open from fully-seated  
IJ = Idling jet  
POS = Needle clip position from top  
MJ = Main jet

#### NICHT FÜR STRASSEN BETRIEB

Kraftstoff: Super Bleifrei ROZ 95/98

#### NOT FOR HIGHWAY USE

Fuel: unleaded fuel with at least RON 95/98

USA = Premium PON 91/94

VERGASERREGULIERUNG CARBURETOR SETTING KEIHIN PWK 36S AG		125 EXC SIX DAYS / EXC 2007						
MEERESHÖHE ALTITUDE ↓	TEMPERATUR TEMPERATURE →	-20°C bis -7°C	-6°C bis 5°C	6°C bis 15°C	16°C bis 24°C	25°C bis 36°C	37°C bis 49°C	
		-2°F to 20°F	19°F to 41°F	42°F to 60°F	61°F to 78°F	79°F to 98°F	99°F to 120°F	
3000 m 10000 ft ↑	LSO ASO LD IJ NADEL NEEDLE	1 45 NOZE	1,5 45 NOZE	1,5 42 NOZF	2 40 NOZF	2 38 NOZG		
2301 m 7501 ft ↑	POS POS HD MJ	4 170	3 168	3 165	2 162	2 160		
2300 m 7500 ft ↑	LSO ASO LD IJ NADEL NEEDLE	1 48 NOZE	1 45 NOZE	1,5 45 NOZE	1,5 42 NOZF	2 40 NOZF	2 38 NOZG	
1501 m 5001 ft ↑	POS POS HD MJ	4 170	4 170	3 168	3 165	2 162	2 160	
1500 m 5000 ft ↑	LSO ASO LD IJ NADEL NEEDLE	0,75 48 NOZD	1 48 NOZE	1 45 NOZE	1,5 45 NOZE	1,5 42 NOZF	2 40 NOZF	
751 m 2501 ft ↑	POS POS HD MJ	4 172	4 170	4 170	3 168	3 165	2 162	
750 m 2500 ft ↑	LSO ASO LD IJ NADEL NEEDLE	0,75 50 NOZD	0,75 48 NOZD	1 48 NOZE	1 45 NOZE	1,5 45 NOZE	1,5 42 NOZF	
301 m 1001 ft ↑	POS POS HD MJ	5 175	4 172	4 170	4 170	3 168	3 165	
300 m 1000 ft ↑	LSO ASO LD IJ NADEL NEEDLE	0,75 52 NOZC	0,75 50 NOZD	0,75 48 NOZD	1 48 NOZE	1 45 NOZE	1,5 45 NOZE	
Meeresniveau Sea level	POS POS HD MJ	5 178	5 175	4 172	4 170	4 170	3 168	

Art.-Nr. 3.206.062-E

LSO = Luftregulierschraube offen  
LD = Leerlaufdüse  
POS = Nadel Clip Position von oben  
HD = Hauptdüse

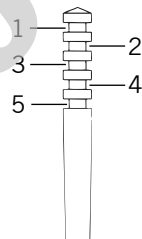

ASO = Air screw open from fully-seated  
IJ = Idling jet  
POS = Needle clip position from top  
MJ = Main jet

**NICHT FÜR STRASSEN BETRIEB**

Kraftstoff: Super Bleifrei ROZ 95

**NOT FOR HIGHWAY USE**

Fuel: unleaded fuel with at least RON 95  
USA = Premium PON 91

**EXC models:** The carburetor adjustments described above only apply to de-throttled motorcycles. Other measures will be required in addition to the carburetor adjustment for full engine performance. Your KTM dealer will be pleased to assist you.

**CHANGES TO YOUR MOTORCYCLE WILL CAUSE YOU TO LOSE YOUR ROAD APPROVAL. IT WILL BE ILLEGAL TO OPERATE THE MOTORCYCLE ON PUBLIC ROADS! YOUR INSURANCE COVERAGE WILL ALSO BE CANCELLED!**

VERGASERREGULIERUNG CARBURETOR SETTING KEIHIN PWK 39		144 SX 2007						
MEERESHÖHE ALTITUDE ↓	TEMPERATUR TEMPERATURE →	-20°C bis -7°C -2°F to 20°F	-6°C bis 5°C 19°F to 41°F	6°C bis 15°C 42°F to 60°F	16°C bis 24°C 61°F to 78°F	25°C bis 36°C 79°F to 98°F	37°C bis 49°C 99°F to 120°F	
3000 m 10000 ft ↑ 2301 m 7501 ft	LSO ASO LD IJ NADEL NEEDLE POS POS HD MJ	1,5 45 N3CG 3 202	2 45 N3CG 3 202	2 42 N3CG 2 200	2,5 42 N3CH 2 198	2,5 40 N3CH 1 195		
2300 m 7500 ft ↑ 1501 m 5001 ft	LSO ASO LD IJ NADEL NEEDLE POS POS HD MJ	1 45 N3CF 4 205	1,5 45 N3CG 3 202	2 45 N3CG 3 202	2 42 N3CG 2 200	2,5 42 N3CH 2 198	2,5 40 N3CH 1 195	
1500 m 5000 ft ↑ 751 m 2501 ft	LSO ASO LD IJ NADEL NEEDLE POS POS HD MJ	1 48 N3CF 4 208	1 45 N3CF 4 205	1,5 45 N3CG 3 202	2 45 N3CG 3 202	2 42 N3CG 2 200	2,5 42 N3CH 2 198	
750 m 2500 ft ↑ 301 m 1001 ft	LSO ASO LD IJ NADEL NEEDLE POS POS HD MJ	1 48 N3CE 4 212	1 48 N3CF 4 208	1 45 N3CF 4 205	1,5 45 N3CG 3 202	2 45 N3CG 3 202	2 42 N3CG 2 200	
300 m 1000 ft ↑ Meeresniveau Sea level	LSO ASO LD IJ NADEL NEEDLE POS POS HD MJ	1 50 N3CE 5 215	1 48 N3CE 4 212	1 48 N3CF 4 208	1 45 N3CF 4 205	1,5 45 N3CG 3 202	2 45 N3CG 3 202	

LSO = Luftregulierschraube offen  
LD = Leerlaufdüse  
POS = Nadel Clip Position von oben  
HD = Hauptdüse

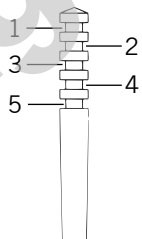

ASO = Air screw open from fully-seated  
IJ = Idling jet  
POS = Needle clip position from top  
MJ = Main jet

**NICHT FÜR STRASSEN BETRIEB**

Kraftstoff: Super Bleifrei ROZ 95

**NOT FOR HIGHWAY USE**

Fuel: unleaded fuel with at least RON 95

USA = Premium PON 91

VERGASERREGULIERUNG CARBURETOR SETTING KEIHIN PWK 36S AG		200 EXC / XC-W / XC 2007						
MEERESHÖHE ALTITUDE ↓	TEMPERATUR TEMPERATURE →	-20°C bis -7°C	-6°C bis 5°C	6°C bis 15°C	16°C bis 24°C	25°C bis 36°C	37°C bis 49°C	
		-2°F to 20°F	19°F to 41°F	42°F to 60°F	61°F to 78°F	79°F to 98°F	99°F to 120°F	
3000 m 10000 ft ↑	LSO ASO LD IJ NADEL NEEDLE	1 42 NOZF	1 42 NOZG	1,5 42 NOZH	1,5 40 NOZH	2 40 NOZI		
2301 m 7501 ft	POS POS HD MJ	4 162	3 160	3 158	2 155	2 152		
2300 m 7500 ft ↑	LSO ASO LD IJ NADEL NEEDLE	1 45 NOZF	1 42 NOZF	1 42 NOZG	1,5 42 NOZH	1,5 40 NOZH	2 40 NOZI	
1501 m 5001 ft	POS POS HD MJ	4 162	4 162	3 160	3 158	2 155	2 152	
1500 m 5000 ft ↑	LSO ASO LD IJ NADEL NEEDLE	1 48 NOZF	1 45 NOZF	1 42 NOZF	1 42 NOZG	1,5 42 NOZH	1,5 40 NOZH	
751 m 2501 ft	POS POS HD MJ	4 165	4 162	4 162	3 160	3 158	2 155	
750 m 2500 ft ↑	LSO ASO LD IJ NADEL NEEDLE	1 48 NOZE	1 48 NOZF	1 45 NOZF	1 42 NOZF	1 42 NOZG	1,5 42 NOZH	
301 m 1001 ft	POS POS HD MJ	4 168	4 165	4 162	4 162	3 160	3 158	
300 m 1000 ft ↑	LSO ASO LD IJ NADEL NEEDLE	0,75 50 NOZE	1 48 NOZE	1 48 NOZF	1 45 NOZF	1 42 NOZF	1 42 NOZG	
Meeresniveau Sea level	POS POS HD MJ	5 170	4 168	4 165	4 162	4 162	3 160	

Art.-Nr. 3.206.062-E

LSO = Luftregulierschraube offen  
LD = Leerlaufdüse  
POS = Nadel Clip Position von oben  
HD = Hauptdüse

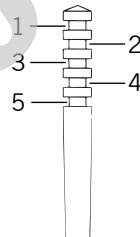

ASO = Air screw open from fully-seated  
IJ = Idling jet  
POS = Needle clip position from top  
MJ = Main jet

**NICHT FÜR STRASSENBETRIEB**  
Kraftstoff: Super Bleifrei ROZ 95

**NOT FOR HIGHWAY USE**  
Fuel: unleaded fuel with at least RON 95  
USA = Premium PON 91

**EXC models:** The carburetor adjustments described above only apply to de-throttled motorcycles. Other measures will be required in addition to the carburetor adjustment for full engine performance. Your KTM dealer will be pleased to assist you.  
**CHANGES TO YOUR MOTORCYCLE WILL CAUSE YOU TO LOSE YOUR ROAD APPROVAL. IT WILL BE ILLEGAL TO OPERATE THE MOTORCYCLE ON PUBLIC ROADS! YOUR INSURANCE COVERAGE WILL ALSO BE CANCELLED!**

Repair manual KTM 125 / 144 / 150 / 200

VERGASERREGULIERUNG CARBURETOR SETTING KEIHIN PWK 39		125 SX 2008						
MEERESHÖHE ALTITUDE ↓	TEMPERATUR TEMPERATURE →	-20°C bis -7°C -2°F to 20°F	-6°C bis 5°C 19°F to 41°F	6°C bis 15°C 42°F to 60°F	16°C bis 24°C 61°F to 78°F	25°C bis 36°C 79°F to 98°F	37°C bis 49°C 99°F to 120°F	
3000 m 10000 ft ↑ 2301 m 7501 ft	LSO ASO LD IJ NADEL NEEDLE POS POS HD MJ	1,5 45 R1469D 2 188	1,75 45 R1470D 2 185	2 42 R1470D 2 182	2,25 40 R1470D 2 180	2,5 38 R1471D 1 178		
2300 m 7500 ft ↑ 1501 m 5001 ft	LSO ASO LD IJ NADEL NEEDLE POS POS HD MJ	1,5 48 R1469D 2 190	1,5 45 R1469D 2 188	1,75 45 R1470D 2 185	2 42 R1470D 2 182	2,25 40 R1470D 2 180	2,5 38 R1471D 1 178	
1500 m 5000 ft ↑ 751 m 2501 ft	LSO ASO LD IJ NADEL NEEDLE POS POS HD MJ	1 48 R1468D 3 192	1,5 48 R1469D 2 190	1,5 45 R1469D 2 188	1,75 45 R1470D 2 185	2 42 R1470D 2 182	2,25 40 R1470D 2 180	
750 m 2500 ft ↑ 301 m 1001 ft	LSO ASO LD IJ NADEL NEEDLE POS POS HD MJ	1 50 R1468D 3 195	1 48 R1468D 3 192	1,5 48 R1469D 2 190	1,5 45 R1469D 2 188	1,75 45 R1470D 2 185	2 42 R1470D 2 182	
300 m 1000 ft ↑ Meeresniveau Sea level	LSO ASO LD IJ NADEL NEEDLE POS POS HD MJ	0,75 52 R1468D 4 198	1 50 R1468D 3 195	1 48 R1468D 3 192	1,5 48 R1469D 2 190	1,5 45 R1469D 2 188	1,75 45 R1470D 2 185	

LSO = Luftregulierschraube offen  
LD = Leerlaufdüse  
POS = Nadel Clip Position von oben  
HD = Hauptdüse

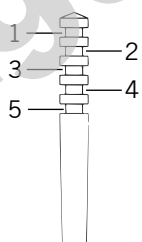

ASO = Air screw open from fully-seated  
IJ = Idling jet  
POS = Needle clip position from top  
MJ = Main jet

#### NICHT FÜR STRASSEN BETRIEB

Kraftstoff: Super Bleifrei ROZ 95

#### NOT FOR HIGHWAY USE

Fuel: unleaded fuel with at least RON 95

USA = Premium PON 91



VERGASERREGULIERUNG CARBURETOR SETTING KEIHIN PWK 36S AG		125 EXC/EXC SIX DAYS 2008						
MEERESHÖHE ALTITUDE ↓	TEMPERATUR TEMPERATURE →	-20°C bis -7°C	-6°C bis 5°C	6°C bis 15°C	16°C bis 24°C	25°C bis 36°C	37°C bis 49°C	
		-2°F to 20°F	19°F to 41°F	42°F to 60°F	61°F to 78°F	79°F to 98°F	99°F to 120°F	
3000 m 10000 ft ↑	LSO ASO LD IJ NADEL NEEDLE	1 45 NOZE	1,5 45 NOZE	1,5 42 NOZF	2 40 NOZF	2 38 NOZG		
2301 m 7501 ft ↑	POS POS HD MJ	4 170	3 168	3 165	2 162	2 160		
2300 m 7500 ft ↑	LSO ASO LD IJ NADEL NEEDLE	1 48 NOZE	1 45 NOZE	1,5 45 NOZE	1,5 42 NOZF	2 40 NOZF	2 38 NOZG	
1501 m 5001 ft ↑	POS POS HD MJ	4 170	4 170	3 168	3 165	2 162	2 160	
1500 m 5000 ft ↑	LSO ASO LD IJ NADEL NEEDLE	0,75 48 NOZD	1 48 NOZE	1 45 NOZE	1,5 45 NOZE	1,5 42 NOZF	2 40 NOZF	
751 m 2501 ft ↑	POS POS HD MJ	4 172	4 170	4 170	3 168	3 165	2 162	
750 m 2500 ft ↑	LSO ASO LD IJ NADEL NEEDLE	0,75 50 NOZD	0,75 48 NOZD	1 48 NOZE	1 45 NOZE	1,5 45 NOZE	1,5 42 NOZF	
301 m 1001 ft ↑	POS POS HD MJ	5 175	4 172	4 170	4 170	3 168	3 165	
300 m 1000 ft ↑	LSO ASO LD IJ NADEL NEEDLE	0,75 52 NOZC	0,75 50 NOZD	0,75 48 NOZD	1 48 NOZE	1 45 NOZE	1,5 45 NOZE	
Meeresniveau Sea level	POS POS HD MJ	5 178	5 175	4 172	4 170	4 170	3 168	

Art.-Nr. 3.206.062-E

LSO = Luftregulierschraube offen  
LD = Leerlaufdüse  
POS = Nadel Clip Position von oben  
HD = Hauptdüse

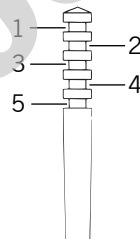

ASO = Air screw open from fully-seated  
IJ = Idling jet  
POS = Needle clip position from top  
MJ = Main jet

**NICHT FÜR STRASSENBETRIEB**  
Kraftstoff: Super Bleifrei ROZ 95

**NOT FOR HIGHWAY USE**  
Fuel: unleaded fuel with at least RON 95  
USA = Premium PON 91

**EXC models:** The carburetor adjustments described above only apply to dethrottled motorcycles. Other measures will be required in addition to the carburetor adjustment for full engine performance. Your KTM dealer will be pleased to assist you.  
**CHANGES TO YOUR MOTORCYCLE WILL CAUSE YOU TO LOSE YOUR ROAD APPROVAL. IT WILL BE ILLEGAL TO OPERATE THE MOTORCYCLE ON PUBLIC ROADS! YOUR INSURANCE COVERAGE WILL ALSO BE CANCELLED!**

Repair manual KTM 125 / 144 / 150 / 200

VERGASERREGULIERUNG CARBURETOR SETTING KEIHIN PWK 39		144 SX 2008						
MEERESHÖHE ALTITUDE ↓	TEMPERATUR TEMPERATURE →	-20°C bis -7°C -2°F to 20°F	-6°C bis 5°C 19°F to 41°F	6°C bis 15°C 42°F to 60°F	16°C bis 24°C 61°F to 78°F	25°C bis 36°C 79°F to 98°F	37°C bis 49°C 99°F to 120°F	
3000 m 10000 ft ↑ 2301 m 7501 ft	LSO ASO LD IJ NADEL NEEDLE POS POS HD MJ	1,5 45 R1471H 3 202	2 45 R1471H 3 202	2 42 R1471H 2 200	2,5 42 R1472H 2 198	2,5 40 R1472H 1 195		
2300 m 7500 ft ↑ 1501 m 5001 ft	LSO ASO LD IJ NADEL NEEDLE POS POS HD MJ	1 45 R1470H 4 205	1,5 45 R1471H 3 202	2 45 R1471H 3 202	2 42 R1471H 2 200	2,5 42 R1472H 2 198	2,5 40 R1472H 1 195	
1500 m 5000 ft ↑ 751 m 2501 ft	LSO ASO LD IJ NADEL NEEDLE POS POS HD MJ	1 48 R1470H 4 208	1 45 R1470H 4 205	1,5 45 R1471H 3 202	2 45 R1471H 3 202	2 42 R1471H 2 200	2,5 42 R1472H 2 198	
750 m 2500 ft ↑ 301 m 1001 ft	LSO ASO LD IJ NADEL NEEDLE POS POS HD MJ	1 48 R1469H 4 212	1 48 R1470H 4 208	1 45 R1470H 4 205	1,5 45 R1471H 3 202	2 45 R1471H 3 202	2 42 R1471H 2 200	
300 m 1000 ft ↑ Meeresniveau Sea level	LSO ASO LD IJ NADEL NEEDLE POS POS HD MJ	1 50 R1468H 5 215	1 48 R1469H 4 212	1 48 R1470H 4 208	1 45 R1470H 4 205	1,5 45 R1471H 3 202	2 45 R1471H 3 202	

LSO = Luftregulierschraube offen  
LD = Leerlaufdüse  
POS = Nadel Clip Position von oben  
HD = Hauptdüse

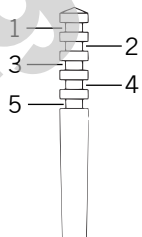

ASO = Air screw open from fully-seated  
IJ = Idling jet  
POS = Needle clip position from top  
MJ = Main jet

#### NICHT FÜR STRASSEN BETRIEB

Kraftstoff: Super Bleifrei ROZ 95

#### NOT FOR HIGHWAY USE

Fuel: unleaded fuel with at least RON 95

USA = Premium PON 91

VERGASERREGULIERUNG CARBURETOR SETTING KEIHIN PWK 36S AG		200 XC/XC-W/EXC 2008						
MEERESHÖHE ALTITUDE ↓	TEMPERATUR TEMPERATURE →	-20°C bis -7°C -2°F to 20°F	-6°C bis 5°C 19°F to 41°F	6°C bis 15°C 42°F to 60°F	16°C bis 24°C 61°F to 78°F	25°C bis 36°C 79°F to 98°F	37°C bis 49°C 99°F to 120°F	
3000 m 10000 ft ↑	LSO ASO LD IJ NADEL NEEDLE	1 42 NOZH	1 42 NOZH	1,5 42 NOZI	1,5 40 NOZI	2 40 NOZJ		
2301 m 7501 ft ↑	POS POS HD MJ	4 162	3 160	3 158	2 155	2 152		
2300 m 7500 ft ↑	LSO ASO LD IJ NADEL NEEDLE	1 45 NOZH	1 42 NOZH	1 42 NOZH	1,5 42 NOZI	1,5 40 NOZI	2 40 NOZJ	
1501 m 5001 ft ↑	POS POS HD MJ	4 162	4 162	3 160	3 158	2 155	2 152	
1500 m 5000 ft ↑	LSO ASO LD IJ NADEL NEEDLE	1 45 NOZG	1 45 NOZH	1 42 NOZH	1 42 NOZH	1,5 42 NOZI	1,5 40 NOZI	
751 m 2501 ft ↑	POS POS HD MJ	4 165	4 162	4 162	3 160	3 158	2 155	
750 m 2500 ft ↑	LSO ASO LD IJ NADEL NEEDLE	1 48 NOZG	1 45 NOZG	1 45 NOZH	1 42 NOZH	1 42 NOZH	1,5 42 NOZI	
301 m 1001 ft ↑	POS POS HD MJ	4 168	4 165	4 162	4 162	3 160	3 158	
300 m 1000 ft ↑	LSO ASO LD IJ NADEL NEEDLE	0,75 50 NOZF	1 48 NOZG	1 48 NOZG	1 45 NOZH	1 42 NOZH	1 42 NOZH	
Meeresniveau Sea level	POS POS HD MJ	5 170	4 168	4 165	4 162	4 162	3 160	

Art.-Nr. 3.206.062-E

LSO = Luftregulierschraube offen  
LD = Leerlaufdüse  
POS = Nadel Clip Position von oben  
HD = Hauptdüse

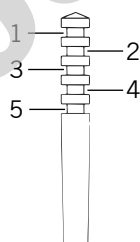

ASO = Air screw open from fully-seated  
IJ = Idling jet  
POS = Needle clip position from top  
MJ = Main jet

**NICHT FÜR STRASSEN BETRIEB**

Kraftstoff: Super Bleifrei ROZ 95

**NOT FOR HIGHWAY USE**

Fuel: unleaded fuel with at least RON 95  
USA = Premium PON 91

**EXC models:** The carburetor adjustments described above only apply to de-throttled motorcycles. Other measures will be required in addition to the carburetor adjustment for full engine performance. Your KTM dealer will be pleased to assist you.

**CHANGES TO YOUR MOTORCYCLE WILL CAUSE YOU TO LOSE YOUR ROAD APPROVAL. IT WILL BE ILLEGAL TO OPERATE THE MOTORCYCLE ON PUBLIC ROADS! YOUR INSURANCE COVERAGE WILL ALSO BE CANCELLED!**

VERGASERREGULIERUNG CARBURETOR SETTING KEIHIN PWK-S 38 AG		125 SX 2009/2010						
MEERESHÖHE ALTITUDE ↓	TEMPERATUR TEMPERATURE →	-20°C bis -7°C	-6°C bis 5°C	6°C bis 15°C	16°C bis 24°C	25°C bis 36°C	37°C bis 49°C	
		-2°F to 20°F	19°F to 41°F	42°F to 60°F	61°F to 78°F	79°F to 98°F	99°F to 120°F	
3000 m 10000 ft ↑ 2301 m 7501 ft	LSO ASO LD IJ NADEL NEEDLE POS POS HD MJ	1,5 42 NOZI 3 182	2 42 NOZI 3 182	2,5 40 NOZI 2 180	2,5 38 NOZJ 2 178	3 38 NOZK 1 175		
2300 m 7500 ft ↑ 1501 m 5001 ft	LSO ASO LD IJ NADEL NEEDLE POS POS HD MJ	1,5 42 NOZI 4 185	1,5 42 NOZI 3 182	2 42 NOZI 3 182	2,5 40 NOZI 2 180	2,5 38 NOZJ 2 178	3 38 NOZK 1 175	
1500 m 5000 ft ↑ 751 m 2501 ft	LSO ASO LD IJ NADEL NEEDLE POS POS HD MJ	1,5 45 NOZH 4 188	1,5 42 NOZI 4 185	1,5 42 NOZI 3 182	2 42 NOZI 3 182	2,5 40 NOZI 2 180	2,5 38 NOZJ 2 178	
750 m 2500 ft ↑ 301 m 1001 ft	LSO ASO LD IJ NADEL NEEDLE POS POS HD MJ	1,5 48 NOZG 4 190	1,5 45 NOZH 4 188	1,5 42 NOZI 4 185	1,5 42 NOZI 3 182	2 42 NOZI 3 182	2,5 40 NOZI 2 180	
300 m 1000 ft ↑ Meeresniveau Sea level	LSO ASO LD IJ NADEL NEEDLE POS POS HD MJ	1 48 NOZF 5 192	1,5 48 NOZG 4 190	1,5 45 NOZH 4 188	1,5 42 NOZI 4 185	1,5 42 NOZI 3 182	2 42 NOZI 3 182	

LSO = Luftregulierschraube offen  
LD = Leerlaufdüse  
POS = Nadel Clip Position von oben  
HD = Hauptdüse

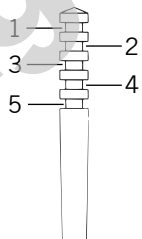

ASO = Air screw open from fully-seated  
IJ = Idling jet  
POS = Needle clip position from top  
MJ = Main jet

**NICHT FÜR STRASSEN BETRIEB**  
**NICHT FÜR SANDSTRECKEN**

Schieber: 7 mit Ausschnitt  
Kraftstoff: Super Bleifrei ROZ 95

**NOT FOR HIGHWAY USE AND SAND TRACKS**

Throttle: 7 with cut  
Fuel: unleaded fuel with at least RON 95  
USA = Premium PON 91

VERGASERREGULIERUNG CARBURETOR SETTING KEIHIN PWK-S 38 AG		150 SX/XC USA 2009/2010						
MEERESHÖHE ALTITUDE ↓	TEMPERATUR TEMPERATURE →	-20°C bis -7°C -2°F to 20°F	-6°C bis 5°C 19°F to 41°F	6°C bis 15°C 42°F to 60°F	16°C bis 24°C 61°F to 78°F	25°C bis 36°C 79°F to 98°F	37°C bis 49°C 99°F to 120°F	
3000 m 10000 ft ↑	LSO ASO LD IJ NADEL NEEDLE POS POS HD MJ	1,5 42 NOZI 2 182	2 42 NOZI 2 182	2 40 NOZI 2 180	2,5 40 NOZJ 1 178	3 38 NOZK 1 175		
2300 m 7500 ft ↑	LSO ASO LD IJ NADEL NEEDLE POS POS HD MJ	1,5 42 NOZI 3 185	1,5 42 NOZI 2 182	2 42 NOZI 2 182	2 40 NOZI 2 180	2,5 40 NOZJ 1 178	3 38 NOZK 1 175	
1500 m 5000 ft ↑	LSO ASO LD IJ NADEL NEEDLE POS POS HD MJ	1,5 45 NOZH 3 188	1,5 42 NOZI 3 185	1,5 42 NOZI 2 182	2 42 NOZI 2 182	2 40 NOZI 2 180	2,5 40 NOZJ 1 178	
750 m 2500 ft ↑	LSO ASO LD IJ NADEL NEEDLE POS POS HD MJ	1,5 48 NOZG 4 190	1,5 45 NOZH 3 188	1,5 42 NOZI 3 185	1,5 42 NOZI 2 182	2 42 NOZI 2 182	2 40 NOZI 2 180	
300 m 1000 ft ↑ Meeresniveau Sea level	LSO ASO LD IJ NADEL NEEDLE POS POS HD MJ	1,5 48 NOZF 5 192	1,5 48 NOZG 4 190	1,5 45 NOZH 3 188	1,5 42 NOZI 3 185	1,5 42 NOZI 2 182	2 42 NOZI 2 182	

Art.-Nr. 3.206.062-E

LSO = Luftregulierschraube offen  
LD = Leerlaufdüse  
POS = Nadel Clip Position von oben  
HD = Hauptdüse

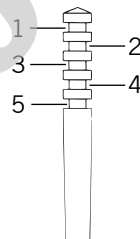

ASO = Air screw open from fully-seated  
IJ = Idling jet  
POS = Needle clip position from top  
MJ = Main jet

**NICHT FÜR STRASSENBETRIEB  
NICHT FÜR SANDSTRECKEN**

Schieber: 6,5 mit Ausschnitt  
Kraftstoff: Super Bleifrei ROZ 95

**NOT FOR HIGHWAY USE AND SAND TRACKS**

Throttle: 6.5 with cut  
Fuel: unleaded fuel with at least RON 95  
USA = Premium PON 91

Repair manual / KTM 125 / 144 / 150 / 200

VERGASERREGULIERUNG CARBURETOR SETTING KEIHIN PWK 36S AG		125 EXC/EXC SIX DAYS 2009/2010					
MEERESHÖHE ALTITUDE ↓	TEMPERATUR TEMPERATURE →	-20°C bis -7°C	-6°C bis 5°C	6°C bis 15°C	16°C bis 24°C	25°C bis 36°C	37°C bis 49°C
		-2°F to 20°F	19°F to 41°F	42°F to 60°F	61°F to 78°F	79°F to 98°F	99°F to 120°F
3000 m 10000 ft ↑	LSO ASO LD IJ NADEL NEEDLE POS POS HD MJ	1 45 NOZE 4 170	1,5 45 NOZE 3 168	1,5 42 NOZF 3 165	2 40 NOZF 2 162	2 38 NOZG 2 160	
2300 m 7500 ft ↑	LSO ASO LD IJ NADEL NEEDLE POS POS HD MJ	1 48 NOZE 4 170	1 45 NOZE 4 170	1,5 45 NOZE 3 168	1,5 42 NOZF 3 165	2 40 NOZF 2 162	2 38 NOZG 2 160
1500 m 5000 ft ↑	LSO ASO LD IJ NADEL NEEDLE POS POS HD MJ	0,75 48 NOZD 4 172	1 48 NOZE 4 170	1 45 NOZE 4 170	1,5 45 NOZE 3 168	1,5 42 NOZF 3 165	2 40 NOZF 2 162
750 m 2500 ft ↑	LSO ASO LD IJ NADEL NEEDLE POS POS HD MJ	0,75 50 NOZD 5 175	0,75 48 NOZD 4 172	1 48 NOZE 4 170	1 45 NOZE 4 170	1,5 45 NOZE 3 168	1,5 42 NOZF 3 165
300 m 1000 ft ↑ Meeresniveau Sea level	LSO ASO LD IJ NADEL NEEDLE POS POS HD MJ	0,75 52 NOZC 5 178	0,75 50 NOZD 5 175	0,75 48 NOZD 4 172	1 48 NOZE 4 170	1 45 NOZE 4 170	1,5 45 NOZE 3 168

LSO = Luftregulierschraube offen  
LD = Leerlaufdüse  
POS = Nadel Clip Position von oben  
HD = Hauptdüse

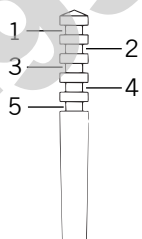

ASO = Air screw open from fully-seated  
IJ = Idling jet  
POS = Needle clip position from top  
MJ = Main jet

**NICHT FÜR STRASSEN BETRIEB**  
**NICHT FÜR SANDSTRECKEN**

Kraftstoff: Super Bleifrei ROZ 95

**NOT FOR HIGHWAY USE AND SAND TRACKS**

Fuel: unleaded fuel with at least RON 95  
USA = Premium PON 91

**EXC models:** The carburetor adjustments described above only apply to de-throttled motorcycles. Other measures will be required in addition to the carburetor adjustment for full engine performance. Your KTM dealer will be pleased to assist you.

**CHANGES TO YOUR MOTORCYCLE WILL CAUSE YOU TO LOSE YOUR ROAD APPROVAL. IT WILL BE ILLEGAL TO OPERATE THE MOTORCYCLE ON PUBLIC ROADS! YOUR INSURANCE COVERAGE WILL ALSO BE CANCELLED!**

VERGASERREGULIERUNG CARBURETOR SETTING KEIHIN PWK 36S AG		200 XC/XC-W/EXC 2009/2010					
MEERESHÖHE ALTITUDE ↓	TEMPERATUR TEMPERATURE →	-20°C bis -7°C	-6°C bis 5°C	6°C bis 15°C	16°C bis 24°C	25°C bis 36°C	37°C bis 49°C
		-2°F to 20°F	19°F to 41°F	42°F to 60°F	61°F to 78°F	79°F to 98°F	99°F to 120°F
3000 m 10000 ft ↑	LSO ASO LD IJ NADEL NEEDLE	1 42 NOZH	1 42 NOZH	1,5 42 NOZI	1,5 40 NOZI	2 40 NOZJ	
2301 m 7501 ft	POS POS HD MJ	4 162	3 160	3 158	2 155	2 152	
2300 m 7500 ft ↑	LSO ASO LD IJ NADEL NEEDLE	1 45 NOZH	1 42 NOZH	1 42 NOZH	1,5 42 NOZI	1,5 40 NOZI	2 40 NOZJ
1501 m 5001 ft	POS POS HD MJ	4 162	4 162	3 160	3 158	2 155	2 152
1500 m 5000 ft ↑	LSO ASO LD IJ NADEL NEEDLE	1 45 NOZG	1 45 NOZH	1 42 NOZH	1 42 NOZH	1,5 42 NOZI	1,5 40 NOZI
751 m 2501 ft	POS POS HD MJ	4 165	4 162	4 162	3 160	3 158	2 155
750 m 2500 ft ↑	LSO ASO LD IJ NADEL NEEDLE	1 48 NOZG	1 45 NOZG	1 45 NOZH	1 42 NOZH	1 42 NOZH	1,5 42 NOZI
301 m 1001 ft	POS POS HD MJ	4 168	4 165	4 162	4 162	3 160	3 158
300 m 1000 ft ↑	LSO ASO LD IJ NADEL NEEDLE	0,75 50 NOZF	1 48 NOZG	1 48 NOZG	1 45 NOZH	1 42 NOZH	1 42 NOZH
Meeresniveau Sea level	POS POS HD MJ	5 170	4 168	4 165	4 162	4 162	3 160

Art.-Nr. 3.206.062-E

LSO = Luftregulierschraube offen  
LD = Leerlaufdüse  
POS = Nadel Clip Position von oben  
HD = Hauptdüse

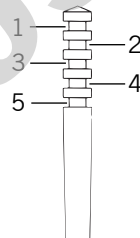

ASO = Air screw open from fully-seated  
IJ = Idling jet  
POS = Needle clip position from top  
MJ = Main jet

**NICHT FÜR STRASSEN BETRIEB**  
**NICHT FÜR SANDSTRECKEN**  
Kraftstoff: Super Bleifrei ROZ 95

**NOT FOR HIGHWAY USE AND SAND TRACKS**  
Fuel: unleaded fuel with at least RON 95  
USA = Premium PON 91

**EXC models:** The carburetor adjustments described above only apply to dethrottled motorcycles. Other measures will be required in addition to the carburetor adjustment for full engine performance. Your KTM dealer will be pleased to assist you.  
**CHANGES TO YOUR MOTORCYCLE WILL CAUSE YOU TO LOSE YOUR ROAD APPROVAL. IT WILL BE ILLEGAL TO OPERATE THE MOTORCYCLE ON PUBLIC ROADS! YOUR INSURANCE COVERAGE WILL ALSO BE CANCELLED!**

Repair manual KTM 125 / 144 / 150 / 200

**PartShark.com**  
**877-999-5686**



# PERIODIC MAINTENANCE SCHEDULE

# 11

## INDEX

<b>UP TO 2000</b>	
125 / 200 .....	.11-2
<b>MODEL 2001/2002</b>	
125 / 200 SX, MXC, EXC .....	.11-3
<b>MODEL 2000/2001</b>	
125 EXE / SUPERMOTO .....	.11-5
<b>MODEL 2003</b>	
125 / 200 .....	.11-7
<b>MODEL 2004</b>	
125 / 200 .....	.11-9
<b>MODEL 2005</b>	
125 / 200 .....	.11-11
<b>MODEL 2006</b>	
125 / 200 .....	.11-14
<b>MODEL 2007</b>	
EXC / EXC SIX DAYS / XC / XC-W .....	.11-16
SX / SXS .....	.11-18
<b>MODEL 2008</b>	
125 EXC/EXC SIX DAYS, 200 XC/XC-W/EXC .....	.11-20
125/144 SX .....	.11-22
<b>MODEL 2009</b>	
125/150 SX .....	.11-24
125 EXC/EXC SIX DAYS, 200 XC/XC-W/EXC .....	.11-26
<b>MODEL 2010</b>	
125/150 SX .....	.11-28
125 EXC/EXC SIX DAYS, 150 XC USA, 200 XC-W/EXC .....	.11-30

**PartShark.com**  
**877-999-5686**

## PERIODIC LUBRICATION AND MAINTENANCE SCHEDULE

125-200 6.98



**AT A REGULAR COMPETITION USE OF THE BIKE, THE 4000 KM (2500 MILES) SERVICE IS TO BE DONE AFTER EVERY RACE**

	KTM rider		KTM dealer			
	before each start	after washing	1st service after 1000 km (600 miles) or 10 hours	after 2000 km (1250 miles) or 20 hours	after 4000 km (2500 miles) or once a year	at least once a year
Check transmission oil level	•					
Change transmission oil			•		•	•
Check spark plug and electrode gap				•	•	•
Change spark plug					•	
Functional testing of the exhaust control system						•
Check intake manifold for leaks and cracks	•				•	
Drain and clean carburetor float chamber		•			•	
Adjust idling			•		•	
Check breather hoses of engine case and gas tank for correct position without buckles			•			
Clean and check airfilter element, box and carburetor connection boot		•			•	•
Check chain, sprockets, guides and chain wear	•		•		•	
Clean and lubricate chain	•				•	
Check chain tension	•		•		•	
Check coolant level	•		•		•	
Check quality of antifreeze						•
Check cooling system for leaks - visual inspection	•		•		•	
Check exhaust system for cracks and leaks					•	
Replace glass fiber yarn of silencer					•	
Check of the exhaust suspension system					•	
Check brake fluid level front and rear	•		•		•	
Change brake fluid						•
Check thickness of disc brake pads	•				•	
Check brake discs					•	
Inspect condition and installation of front and rear brake hoses	•		•		•	
Check free travel and free movability of hand brake lever and foot brake lever	•		•		•	
Check the oil level in the master cylinder of the hydraulic clutch				•	•	
Change the oil of the hydraulic clutch						•
Check telescopic fork action	•				•	
Check telescopic fork for leaks					•	
Push up the protective bellows and remove the dirt; the drain holes must be free of obstructions (Marzocchi fork)		•	•	•	•	
Clean the dust scrubbers of the telescopic force (WP Extreme fork)		•		•	•	
Undo the bleeder screws at the fork legs					•	
Change oil of telescopic fork						•
Service telescopic fork completely						•
Check steering head bearing free play			•		•	
Clean and regrease steering head bearing					•	•
Check setting and damping of shock absorber	•				•	
Service shock absorber completely						•
Grease swingarm needle bearings (don't grease the pivot bearing for the shock absorber)						•
Check for even spoke tension and rim alignment	•		•		•	
Check wheel bearings	•				•	
Check tires for cuts and air pressure	•				•	
Check cables for damage and free movement	•				•	
Adjust and oil control cables		•	•		•	
Check electrical system	•		•		•	
Check battery holder and connections (CH, Singapore)					•	
Check adjustment of headlight					•	
Apply contact spray to light switches, flasher switches and ignition lock		•			•	
Check all bolts, nuts, bolts and clamps for proper tightness	•		•		•	
Clean and lubricate control lever pivot points		•	•	•	•	



# PERIODIC MAINTENANCE SCHEDULE 2001/02

125/200 SX/MXC/EXC

A washed motorcycle can be checked more quickly which saves money!		1. service after 10 hours or 1000 kilometer	after 20 hours or 2000 kilometer	after 4000 kilometer or once a year	
ENGINE	Check gear box oil level		●		
	Change gear box oil	●		●	
	Check spark plugs, adjust distance between electrodes	●	●		
	Renew spark plugs			●	
CARBURETOR	Check the carburettor connection boot for cracks and leaks			●	
	Check idle speed setting	●		●	
	Check that vent hoses are not damaged or bent	●		●	
ADD-ON-PARTS	Check cooling system for leaks, check quantity of anti freeze	●		●	
	Check exhaust system for leaks and fitment			●	
	Check cables for damage, smooth operation, bends; adjust and lubricate	●		●	
	Check oil level of the clutch master cylinder	●	●	●	
	Clean air filter and filter box			●	
	Check electric wires for damage and bends			●	
	Check headlamp setting			●	
	Check function of electric systems (low-, high beam, brake light, indicator, indicator lamps, speedometer illumination, horn, emergency OFF switch or button)	●		●	
	BRAKES	Check brake fluid level, lining thickness, brake lining	●		●
		Check brake lines for damage and leaks	●		●
Check/adjust smooth operation and free travel of handbrake/foot brake lever		●		●	
Check tightness of brake system bolts		●		●	
CHASSIS	Check shock absorber and fork for leaks and function	●		●	
	Clean dust bellows			●	
	Bleed fork legs			●	
	Check swing arm bearings			●	
	Check/adjust steering head bearings	●		●	
	Check tightness of all chassis bolts (triple clamps, fork leg axle passage axle nuts and bolts, swing arm bearings, shock absorber)	●		●	
WHEELS	Check spoke tension and rim join			●	
	Check tyres and air pressure	●		●	
	Check chain, rear sprockets and chain guides for wear, fitment and tension	●		●	
	Lubricate chain	●		●	
	Check clearance of wheel bearings	●		●	

## IMPORTANT RECOMMENDED MAINTENANCE WORK THAT CAN BE CARRIED OUT BY EXTRA ORDER

	at least once a year	every 2 years or 20000 km
Check function of exhaust control	●	
Complete maintenance of shock absorber	●	
Complete maintenance of fork		●
Clean and grease steering head bearings and gasket elements	●	
Clean and adjust carburetor	●	
Replace glass fibre yarn filling of the exhaust main silencer	●	
Treat electric contacts and switches with contact grease	●	
Change hydraulic clutch fluid	●	
Change brake fluid	●	

**IF MOTORCYCLE IS USED FOR COMPETITION 4000KM SERVICE SHOULD BE CARRIED OUT AFTER EVERY RACE! SERVICE INTERVALLS SHOULD NEVER BE EXCEED BY MORE THAN 5 HOURS OR 500 KM! MAINTENANCE WORK DONE BY KTM AUTHORISED WORKSHOPS IS NOT A SUBSTITUTE OF CARE AND CHECKS DONE BY THE RIDER!**

### IMPORTANT CHECKS AND MAINTENANCE TO BE CARRIED OUT BY THE RIDER

	Before each start	After every cleaning	For cross- country use	Once a year
Check gear box oil level	●			
Check brake fluid level	●			
Check brake pads for wear	●			
Check lights for function	●			
Check horn for function	●			
Lubricate and adjust cables and nipples		●		
Bleed fork legs regulary			●	
Remove and clean dust bellows regulary			●	
Clean and lubricate chain, check tension and adjust if necessary		●	●	
Clean air filter and filter box			●	
Check tires for pressure and wear	●			
Check cooling liquid level	●			
Check fuel lines for leaks	●			
Empty and clean float chamber		●		
Check all control elements for smooth operation	●			
Check brake performance	●	●		
Treat blank metal parts (with the exception of brake and exhaust systems) with wax-based anti corrosion agent		●		
Treat ignition and steering locks and light switches with contact spray		●		
Check tightness of bolts, nuts and hose clamps regular				●



## PERIODIC MAINTENANCE SCHEDULE

125 EXE  
125 SUPERMOTO

A washed motorcycle can be checked more quickly which saves money!		1. Service after 1000 km	2. Service after 4000 km	every 4000 km or once a year
ENGINE	Check oil level in oil tank and verify kink-less arrangement of bleeder hose		●	● ●
	Change transmission oil	●	●	●
	Check spark plug, set electrode gap, replace plug if necessary		●	
CARBURETOR	Check carburetor connection boots for cracks and leaks		●	●
	Check idle setting and emission values	●	●	●
	Check bleeder hoses for damage and kink-free arrangement	●	●	●
ADD-ON-PARTS	Check cooling system for leaks, antifreeze protection	●	●	●
	Check exhaust system for leaks and suspension		●	●
	Check actuating cables for damage, smooth operation, and kink-less arrangement, and adjust and lubricate	●	●	●
	Check oil level in master cylinder of hydraulic clutch	●	●	●
	Clean air filter and air filter box		●	●
	Check cables for damage and kink-less arrangement		●	●
	Check headlamp adjustment		●	●
	Check electrical system for proper operation (low/high beams, stop light, turn indicators, tell-tale lamps, speedometer illumination, horn, battery holder, and connections)	●	●	●
	Check brake fluid level, lining thickness, and brake discs		●	● ●
	Check brake lines for damage and leaks	●	●	●
BRAKES	Check/adjust smooth operation, free travel of handbrake/footbrake levers		●	● ●
	Check bolts of brake system for tight fit	●	●	●
	Check suspension strut and fork for leaks and proper function	●	●	●
	Clean dust sleeves		●	●
CHASSIS	Bleed fork legs		●	●
	Check swinging-fork pivot		●	●
	Check/adjust steering-head bearing	●	●	●
	Check all chassis bolts for tight fit (fork plates, fork leg, axle nuts/bolts, swinging-fork pivot, suspension strut)	●	●	●
	Check spoke tension and rim join		●	●
	Check tire condition and inflation pressure	●	●	●
WHEELS	Check chain, chain wheels, chain wheel guides for wear, tight fit, and tension	●	●	●
	Lubricate chain	●	●	●
	Check wheel bearings for play	●	●	●

### IMPORTANT RECOMMENDED MAINTENANCE PROCEDURES TO BE PERFORMED BASED ON A SEPARATE SUPPLEMENTARY ORDER

	at least once a year	every 2 year or 20000 km
Verify proper function of exhaust control	●	
Perform complete fork maintenance		●
Perform complete suspension strut maintenance		●
Clean and lubricate the steering-head bearing and sealing elements	●	
Clean and adjust the carburetor	●	
Replace the glass-fiber yarn packing of the main silencer		●
Treat the electrical contacts and switches with contact spray	●	
Replace the oil of the hydraulic clutch	●	
Replace the brake fluid	●	

**SERVICE INTERVALLS SHOULD NEVER BE EXCEED BY MORE THAN 500 KM!**  
MAINTENANCE WORK DONE BY KTM AUTHORISED WORKSHOPS IS NOT A SUBSTITUTE OF CARE AND CHECKS DONE BY THE RIDER!

### IMPORTANT CHECKS AND MAINTENANCE TO BE CARRIED OUT BY THE RIDER

	Before each start	After every cleaning	For cross-country use	Once a year
Check oil level in oil tank and bleeder hose for its kink-less arrangement	●			
Check transmission oil level	●			
Check brake fluid level	●			
Check brake pads for wear	●			
Check lighting system for proper operation	●			
Check horn for proper operation	●			
Lubricate and adjust actuating cables and nipples		●		
Bleed fork legs in regular intervals			●	
Remove and clean dust sleeves in regular intervals			●	
Clean and lubricate chain, check tension and readjust it if necessary		●	●	
Clean air filter and filter box			●	
Check tire inflation pressure and wear	●			
Check coolant level	●			
Check fuel lines for leaks	●			
Drain and clean float chamber		●		
Verify smooth operation of all controls	●			
Check brake performance	●	●		
Treat exposed metal components (except for brake and exhaust systems) with wax-based anti-corrosion agents		●		
Treat ignition/steering lock and light switch with contact spray		●		
Check all bolts, nuts, and hose clamps for their tight fit in regular intervals				●



## PERIODIC MAINTENANCE SCHEDULE 2003

125/200 SX/MXC/EXC

A clean motorcycle can be checked more quickly which saves money!		1st service after 10 hours or 1000 kilometers	after 20 hours or 2000 kilometers	after 4000 kilometer or once a year	
ENGINE	Check gear box oil level		●		
	Change gear box oil	●		●	
	Check spark plugs, adjust distance between electrodes	●	●		
	Renew spark plugs			●	
CARBURETOR	Check the carburetor connection boot for cracks and leaks			●	
	Check idle speed setting	●		●	
	Check that vent hoses are not damaged or bent	●		●	
ADD-ON-PARTS	Check cooling system for leaks, check quantity of antifreeze	●		●	
	Check exhaust system for leaks and fitment			●	
	Check cables for damage, smooth operation, bends; adjust and lubricate	●		●	
	Check oil level of the clutch master cylinder	●	●	●	
	Clean air filter and filter box			●	
	Check electric wires for damage and bends			●	
	Check headlamp setting			●	
	Check function of electric systems (low beam, high beam, brake light, indicator, indicator lamps, speedometer illumination, horn, emergency OFF switch or button)	●		●	
	BRAKES	Check brake fluid level, lining thickness, brake lining	●		●
		Check brake lines for damage and leaks	●		●
Check/adjust smooth operation and free travel of handbrake/foot brake lever		●		●	
Check tightness of brake system bolts		●		●	
CHASSIS	Check shock absorber and fork for leaks and function	●		●	
	Clean dust bellows			●	
	Bleed fork legs			●	
	Check swing arm bearings			●	
	Check/adjust steering head bearings	●		●	
	Check tightness of all chassis bolts (triple clamps, fork leg axle passage axle nuts and bolts, swing arm bearings, shock absorber)	●		●	
WHEELS	Check spoke tension and rim joint			●	
	Check tires and air pressure	●		●	
	Check chain, rear sprockets and chain guides for wear, fitment and tension	●		●	
	Lubricate chain	●		●	
	Check clearance of wheel bearings	●		●	

### IMPORTANT RECOMMENDED MAINTENANCE WORK THAT CAN BE CARRIED OUT BY EXTRA ORDER

	at least once a year	every 2 years or 20000 km
Check function of exhaust control	●	
Complete maintenance of shock absorber	●	
Complete maintenance of fork		●
Clean and grease steering head bearings and gasket elements	●	
Clean and adjust carburetor	●	
Replace glass fibre- yarn filling of the exhaust main silencer	●	
Treat electric contacts and switches with contact grease	●	
Change hydraulic clutch fluid	●	
Change brake fluid	●	

**IF MOTORCYCLE IS USED FOR COMPETITION 4000KM SERVICE SHOULD BE CARRIED OUT AFTER EVERY RACE!  
SERVICE INTERVALS SHOULD NEVER BE EXCEEDED BY MORE THAN 5 HOURS OR 500 KM!  
MAINTENANCE WORK DONE BY KTM AUTHORISED WORKSHOPS IS NOT A SUBSTITUTE FOR CARE AND CHECKS DONE BY THE RIDER!**



### IMPORTANT CHECKS AND MAINTENANCE TO BE CARRIED OUT BY THE RIDER

	Before each start	After every cleaning	For cross-country use	Once a year
Check gear box oil level	●			
Check brake fluid level	●			
Check brake pads for wear	●			
Check lights for function	●			
Check horn for function	●			
Lubricate and adjust cables and nipples		●		
Bleed fork legs regularly			●	
Remove and clean dust bellows regularly			●	
Clean and lubricate chain, check tension and adjust if necessary		●	●	
Clean air filter and filter box			●	
Check tires for pressure and wear	●			
Check cooling liquid level	●			
Check fuel lines for leaks	●			
Empty and clean float chamber		●		
Check all control elements for smooth operation	●			
Check brake performance	●	●		
Treat blank metal parts (with the exception of brake and exhaust systems) with wax-based anti corrosion agent		●		
Treat ignition and steering locks and light switches with contact spray		●		
Check tightness of bolts, nuts and hose clamps regularly				●



# PERIODIC MAINTENANCE SCHEDULE 2004

125/200 SX/EXC

A clean motorcycle can be checked more quickly which saves money!		1st service after 10 hours or 1000 kilometers	after 20 hours or 2000 kilometers	after 4000 kilometer or once a year
ENGINE	Check gear box oil level		●	
	Change gear box oil	●		●
	Check spark plugs, adjust distance between electrodes	●	●	
	Renew spark plugs			●
CARBURETOR	Check the carburetor connection boot for cracks and leaks			●
	Check idle speed setting	●		●
ADD-ON-PARTS	Check that vent hoses are not damaged or bent	●		●
	Check cooling system for leaks, check quantity of antifreeze	●		●
	Check exhaust system for leaks and fitment			●
	Check cables for damage, smooth operation, bends; adjust and lubricate	●		●
	Check oil level of the clutch master cylinder	●	●	●
	Clean air filter and filter box			●
	Check electric wires for damage and bends			●
	Check headlamp setting			●
	Check function of electric systems (low beam, high beam, break light, indicator, indicator lamps, speedometer illumination, horn, emergency OFF switch or button)	●		●
	BRAKES	Check brake fluid level, lining thickness, brake lining	●	
Check brake lines for damage and leaks		●		●
Check/adjust smooth operation and free travel of handbrake/foot brake lever		●		●
Check tightness of brake system bolts		●		●
CHASSIS	Check shock absorber and fork for leaks and function	●		●
	Clean dust bellows			●
	Bleed fork legs			●
	Check swing arm bearings			●
	Check/adjust steering head bearings	●		●
	Check tightness of all chassis bolts (triple clamps, fork leg axle passage axle nuts and bolts, swing arm bearings, shock absorber)	●		●
WHEELS	Check spoke tension and rim joint			●
	Check tires and air pressure	●		●
	Check chain, rear sprockets and chain guides for wear, fitment and tension	●		●
	Lubricate chain	●		●
	Check clearance of wheel bearings	●		●

## IMPORTANT RECOMMENDED MAINTENANCE WORK THAT CAN BE CARRIED OUT BY EXTRA ORDER

	at least once a year	every 2 years or 20000 km
Check function of exhaust control	●	
Complete maintenance of shock absorber	●	
Complete maintenance of fork		●
Clean and grease steering head bearings and gasket elements	●	
Clean and adjust carburetor	●	
Replace glass fibre- yarn filling of the exhaust main silencer	●	
Treat electric contacts and switches with contact grease	●	
Change hydraulic clutch fluid	●	
Change break fluid	●	

**IF MOTORCYCLE IS USED FOR COMPETITION 4000KM SERVICE SHOULD BE CARRIED OUT AFTER EVERY RACE! SERVICE INTERVALS SHOULD NEVER BE EXCEEDED BY MORE THAN 5 HOURS OR 500 KM! MAINTENANCE WORK DONE BY KTM AUTHORISED WORKSHOPS IS NOT A SUBSTITUTE FOR CARE AND CHECKS DONE BY THE RIDER!**

### IMPORTANT CHECKS AND MAINTENANCE TO BE CARRIED OUT BY THE RIDER

	Before each start	After every cleaning	For cross-country use	Once a year
Check gear box oil level	●			
Check brake fluid level	●			
Check brake pads for wear	●			
Check lights for function	●			
Check horn for function	●			
Lubricate and adjust cables and nipples		●		
Bleed fork legs regularly			●	
Remove and clean dust bellows regularly			●	
Clean and lubricate chain, check tension and adjust if necessary		●	●	
Clean air filter and filter box			●	
Check tires for pressure and wear	●			
Check cooling liquid level	●			
Check fuel lines for leaks	●			
Empty and clean float chamber		●		
Check all control elements for smooth operation	●			
Check brake performance	●	●		
Treat blank metal parts (with the exception of brake and exhaust systems) with wax-based anti corrosion agent		●		
Treat ignition and steering locks and light switches with contact spray		●		
Check tightness of bolts, nuts and hose clamps regularly				●

## PERIODIC MAINTENANCE SCHEDULE 2005

A CLEAN MOTORCYCLE CAN BE CHECKED MORE QUICKLY WHICH SAVES MONEY!		125/200 SX/EXC 250/300 SX/MXC/EXC	1st service after 10 hours or 1000 kilometers	after 20 hours or 2000 kilometers	after 40 hours or 4000 kilometers or once a year
<b>Engine</b>	Check gear box oil level			●	
	Change gear box oil		●		●
	Check spark plugs, adjust distance between electrodes		●	●	
	Renew spark plugs				●
<b>Carburetor</b>	Check the carburetor connection boot for cracks and leaks				●
	Check idle speed setting		●		●
	Check that vent hoses are not damaged or bent		●		●
<b>Add-on-parts</b>	Check cooling system for leaks, check quantity of antifreeze		●		●
	Check exhaust system for leaks and fitment				●
	Check cables for damage, smooth operation, bends; adjust and lubricate		●		●
	Check oil level of the clutch master cylinder		●	●	●
	Clean air filter and filter box				●
	Check electric wires for damage and bends				●
	Check headlamp setting				●
	Check function of electric systems (low beam, high beam, break light, indicator, indicator lamps, speedometer illumination, horn, emergency OFF switch or button)		●		●
<b>Brakes</b>	Check brake fluid level, lining thickness, brake lining		●		●
	Check brake lines for damage and leaks		●		●
	Check/adjust smooth operation and free travel of handbrake/foot brake lever		●		●
	Check tightness of brake system screws		●		●
<b>Chassis</b>	Check shock absorber and fork for leaks and function		●		●
	Clean dust bellows				●
	Bleed fork legs				●
	Check swing arm bearings				●
	Check/adjust steering head bearings		●		●
	Check tightness of all chassis screws (triple clamps, fork leg axle passage axle nuts and screws, swing arm bearings, shock absorber)		●		●
<b>Wheels</b>	Check spoke tension and rim joint		●		●
	Check tires and air pressure		●		●
	Check chain, rear sprockets and chain guides for wear, fitment and tension		●		●
	Lubricate chain		●		●
	Check clearance of wheel bearings		●		●

### IMPORTANT RECOMMENDED MAINTENANCE WORK THAT CAN BE CARRIED OUT BY EXTRA ORDER

	at least once a year	every 2 years or 20000 km
Check function of exhaust control	●	
Complete maintenance of shock absorber	●	
Complete maintenance of fork		●
Clean and grease steering head bearings and gasket elements	●	
Clean and adjust carburetor	●	
Replace glass fibre- yarn filling of the exhaust main silencer	●	
Treat electric contacts and switches with contact grease	●	
Change hydraulic clutch fluid	●	
Change break fluid	●	

**IF MOTORCYCLE IS USED FOR COMPETITION 4000KM SERVICE SHOULD BE CARRIED OUT AFTER EVERY RACE!**

SERVICE INTERVALS SHOULD NEVER BE EXCEEDED BY MORE THAN 5 HOURS OR 500 KM!

MAINTENANCE WORK DONE BY KTM AUTHORISED WORKSHOPS IS NOT A SUBSTITUTE FOR CARE AND CHECKS DONE BY THE RIDER!

IMPORTANT CHECKS AND MAINTENANCE TO BE CARRIED OUT BY THE RIDER				
	before each start	after every cleaning	for cross country use	once a year
Check gear box oil level	●			
Check brake fluid level	●			
Check brake pads for wear	●			
Check lights for function	●			
Check horn for function	●			
Lubricate and adjust cables and nipples		●		
Bleed fork legs regularly			●	
Remove and clean dust bellows regularly			●	
Clean and lubricate chain, check tension and adjust if necessary		●	●	
Clean air filter and filter box			●	
Check tires for pressure and wear	●			
Check cooling liquid level	●			
Check fuel lines for leaks	●			
Empty and clean float chamber		●		
Check all control elements for smooth operation	●			
Check brake performance	●	●		
Treat blank metal parts (with the exception of brake and exhaust systems) with wax-based anti corrosion agent		●		
Treat ignition, steering lock and light switches with contact spray		●		
Check tightness of screws, nuts and hose clamps regularly				●

NOTE: IF THE INSPECTION ESTABLISHES THAT PERMISSIBLE TOLERANCES ARE EXCEEDED, THE RESPECTIVE COMPONENTS MUST BE REPLACED.

**RECOMMENDED INSPECTION OF THE 125/200 SX, MXC AND EXC ENGINE  
USED FOR ENDURO COMPETITIONS BY THE KTM WORKSHOP  
(ADDITIONAL ORDER FOR THE KTM WORKSHOP)**

	30 hours	45 hours	60 hours	90 hours	120 hours	135 hours
Check the reed-type intake valve for wear	●	●	●	●	●	●
Check the clutch shoes for wear	●	●	●	●	●	●
Check the length of the clutch springs	●	●	●	●	●	●
Check the cylinder and piston for wear	●	●	●	●	●	●
Check the exhaust control for proper functioning and smooth running	●	●	●	●	●	●
Check the eccentricity of the crankshaft journal	●	●	●	●	●	●
Check the radial clearance of the conrod bearings	●		●		●	
Check the radial clearance of the piston pin main bearing	●		●		●	
Check the crankshaft main bearing for wear	●		●		●	
Replace the crankshaft bearings and conrod bearings		●		●		●
Check the entire transmission including roller and bearings for wear		●		●		●

**RECOMMENDED INSPECTION OF THE 125/200 SX, MXC AND EXC ENGINE  
USED FOR HOBBY- ENDURO BY THE KTM WORKSHOP  
(ADDITIONAL ORDER FOR THE KTM WORKSHOP)**

	60 hours	90 hours	120 hours	180 hours	240 hours	270 hours
Check the reed-type intake valve for wear	●	●	●	●	●	●
Check the clutch shoes for wear	●	●	●	●	●	●
Check the length of the clutch springs	●	●	●	●	●	●
Check the cylinder and piston for wear	●	●	●	●	●	●
Check the exhaust control for proper functioning and smooth running	●	●	●	●	●	●
Check the eccentricity of the crankshaft journal	●	●	●	●	●	●
Check the radial clearance of the conrod bearings	●		●		●	
Check the radial clearance of the piston pin main bearing	●		●		●	
Check the crankshaft main bearing for wear	●		●		●	
Replace the crankshaft bearings and conrod bearings		●		●		●
Check the entire transmission including roller and bearings for wear		●		●		●

NOTE: IF THE INSPECTION ESTABLISHES THAT PERMISSIBLE TOLERANCES ARE EXCEEDED, THE RESPECTIVE COMPONENTS MUST BE REPLACED.



## PERIODIC MAINTENANCE SCHEDULE 2006

125 SX/SXS/EXC/EXC SIX DAYS  
200 EXC/XC/XC-W

A CLEAN MOTORCYCLE CAN BE CHECKED MORE QUICKLY WHICH SAVES MONEY!		after every race	1st service after 10 hours	every 20 hours	every 40 hours	at least once a year
<b>ENGINE</b>	Check gear box oil level			●		
	Change gear box oil	●	●		●	●
	Check spark plugs, adjust distance between electrodes		●	●		
	Renew spark plugs	●			●	
	Clean the spark-plug connector and check for a tight fit	●		●	●	
	Check the screws on the kick starter and shift lever for a tight fit	●		●	●	
<b>CARBURETOR</b>	Check the carburetor connection boot and intake flange for cracks or leaks	●			●	●
	Check idle speed setting	●	●		●	●
	Check that vent hoses are not damaged or bent	●	●		●	●
<b>ADD-ON-PARTS</b>	Check cooling system for leaks, check quantity of antifreeze	●	●		●	●
	Check exhaust system for leaks and fitment	●		●	●	
	Check cables for damage, smooth operation, bends; adjust and lubricate	●	●		●	
	Check the fluid level in the master cylinder of the hydraulic clutch	●	●	●	●	
	Clean air filter and filter box	●	●	●	●	●
	Check electric wires for damage and bends	●			●	
	Check headlamp setting	●			●	
	Check function of electric systems (low beam, high beam, break light, indicator, indicator lamps, speedometer illumination, horn, emergency OFF switch or button)	●	●		●	
<b>BRAKES</b>	Check brake fluid level, brake lining thickness and brake discs	●	●		●	
	Check brake lines for damage and leaks	●	●		●	
	Check/adjust smooth operation and free travel of handbrake lever / foot brake pedal	●	●		●	
	Check the screws and guide bolts on the brake system for a tight fit	●	●		●	
<b>CHASSIS</b>	Check shock absorber and fork for leaks and function	●	●	●	●	
	Clean dust bellows	●		●	●	
	Bleed fork legs	●		●	●	
	Check swing arm bearings	●			●	
	Check/adjust steering head bearings	●	●		●	
	Check tightness of all chassis screws (triple clamps, fork leg axle passage axle nuts and screws, swing arm bearings, shock absorber)	●	●		●	
<b>WHEELS</b>	Check spoke tension and rim joint	●	●	●	●	
	Check tires and air pressure	●	●	●	●	
	Check chain, rear sprockets and chain guides for wear, fitment and tension	●	●	●	●	
	Lubricate chain, Clean and grease the adjusting screws on the chain tensioner	●	●	●	●	
	Check clearance of wheel bearings	●	●		●	

SERVICE INTERVALS SHOULD NEVER BE EXCEEDED BY MORE THAN 5 HOURS!

MAINTENANCE WORK DONE BY KTM AUTHORISED WORKSHOPS IS NOT A SUBSTITUTE FOR CARE AND CHECKS DONE BY THE RIDER!

<b>IMPORTANT RECOMMENDED MAINTENANCE WORK THAT CAN BE CARRIED OUT BY EXTRA ORDER</b>	<b>every 20 hours</b>	<b>every 40 hours</b>	<b>every 80 hours</b>	<b>at least once a year</b>	<b>every 2 years</b>
Clean and adjust carburetor				C/H	
Check the reed-type intake valve for wear	C	C/H	C/H		
Check the wear on the clutch disks and length of the clutch springs	C	C/H	C/H		
Check the cylinder and piston for wear	C	C/H	C/H		
Check function of exhaust control	C/H	C/H	C/H		
Check piston pin bearing	C	C/H	C/H		
Replace the crankshaft main bearings			C/H		
Replace the conrod bearings		C	C/H		
Check the entire transmission, the shift mechanism and bearings		C	C/H		
Complete maintenance of fork	C		H	C/H	
Complete maintenance of shock absorber			C		C/H
Clean and grease steering head bearings and gasket elements				C/H	
Replace the sealing cup for the foot brake cylinder	C	C/H	C/H		
Replace glass fibre- yarn filling of the exhaust main silencer	C	C/H	C/H		
Treat electric contacts and switches with contact grease				C/H	
Change brake fluid	C	C/H	C/H	C/H	
Change hydraulic clutch fluid				C/H	

**C** = FOR COMPETITIVE OFFROAD RACING (COMPETITION)

**H** = FOR OFFROAD HOBBY USE

IF THE INSPECTION ESTABLISHES THAT PERMISSIBLE TOLERANCES ARE EXCEEDED, THE RESPECTIVE COMPONENTS MUST BE REPLACED.

<b>IMPORTANT CHECKS AND MAINTENANCE TO BE CARRIED OUT BY THE RIDER</b>	<b>before each start</b>	<b>after every cleaning</b>	<b>for cross country use</b>	<b>once a year</b>
Check gear box oil level	●			
Check brake fluid level	●			
Check brake pads for wear	●			
Check lights for function	●			
Check horn for function	●			
Lubricate and adjust cables and nipples		●		
Bleed fork legs regularly			●	
Remove and clean dust bellows regularly			●	
Clean and lubricate chain, check tension and adjust if necessary		●	●	
Clean air filter and filter box		●	●	
Check tires for pressure and wear	●			
Check cooling liquid level	●			
Check fuel lines for leaks	●			
Empty and clean float chamber		●		●
Remove, clean and oil the throttle slide		●		
Check all control elements for smooth operation	●			
Check brake performance	●	●		
Treat blank metal parts (with the exception of brake and exhaust systems) with wax-based anti corrosion agent		●		
Treat ignition, steering lock and light switches with contact spray		●		
Check tightness of screws, nuts and hose clamps regularly				●





## PERIODIC MAINTENANCE SCHEDULE 2007

### 125 EXC/EXC SIX DAYS, 200 XC/XC-W/EXC 2007

A CLEAN MOTORCYCLE CAN BE CHECKED MORE QUICKLY WHICH SAVES MONEY

		Before each race	1st service after 10 hours	every 20 hours	every 40 hours	at least once a year
<b>ENGINE</b>	Check gear box oil level			●		
	Change gear box oil	●	●		●	●
	Check spark plugs, adjust distance between electrodes		●	●		
	Renew spark plugs	●			●	
	Clean the spark-plug connector and check for a tight fit	●		●	●	
	Check the screws on the kick starter and shift lever for a tight fit	●		●	●	
<b>CARBURETOR</b>	Check the carburetor connection boot and intake flange for cracks or leaks	●			●	●
	Check idle speed setting	●	●		●	●
	Check that vent hoses are not damaged or bent	●	●		●	●
<b>ADD-ON-PARTS</b>	Check cooling system for leaks, check quantity of antifreeze	●	●		●	●
	Check exhaust system for leaks and fitment	●		●	●	
	Check cables for damage, smooth operation, bends; adjust and lubricate	●	●		●	
	Check the fluid level in the master cylinder of the hydraulic clutch	●	●	●	●	
	Clean air filter and filter box	●	●	●	●	●
	Check electric wires for damage and bends	●			●	
	Check headlamp setting	●			●	
	Check function of electric systems (low beam, high beam, break light, indicator, indicator lamps, speedometer illumination, horn, emergency OFF switch or button)	●	●		●	
<b>BRAKES</b>	Check brake fluid level, lining thickness, brake lining	●	●		●	
	Check brake lines for damage and leaks	●	●		●	
	Check/adjust the function, smooth operation and free travel of the hand/foot brake lever	●	●		●	
	Check the screws and guide bolts on the brake system for a tight fit	●	●		●	
<b>CHASSIS</b>	Check shock absorber and fork for leaks and function	●	●	●	●	
	Clean dust bellows	●		●	●	
	Bleed fork legs	●		●	●	
	Check swing arm bearings	●			●	
	Check/adjust steering head bearings	●	●		●	
	Check tightness of all chassis screws (triple clamps, fork leg axle passage axle nuts and screws, swing arm bearings, shock absorber)	●	●		●	
<b>WHEELS</b>	Check spoke tension and rim joint	●	●	●	●	
	Check tires and air pressure	●	●	●	●	
	Check chain, rear sprockets and chain guides for wear, fitment and tension	●	●	●	●	
	Lubricate chain, Clean and grease the adjusting screws on the chain tensioner	●	●	●	●	
	Check clearance of wheel bearings	●	●		●	

The kilometer reading for inspection intervals should not exceed 5 hours.

Maintenance work performed by your authorized KTM workshop is not a substitute for care and maintenance by the driver!

<b>125 EXC/EXC SIX DAYS, 200 XC/XC-W/EXC 2007</b>	Every 20 hours	Every 40 hours	Every 60 hours	Every 80 hours	At least once a year	Every 2 years
<b>IMPORTANT SERVICE WORK THAT MUST BE PERFORMED BY AN AUTHORIZED KTM WORKSHOP UNDER A SEPARATE ORDER</b>						
Clean and adjust carburetor					C/H	C/H
Replace the throttle slide, jet needle, float needle valve, needle nozzle				C/H		
Check the reed-type intake valve for wear	C	C/H	C	C/H		
Check the wear on the clutch disks and length of the clutch springs	C	C/H	C	C/H		
Check the cylinder and piston for wear	C	C/H	C	C/H		
Check function of exhaust control	C/H	C/H		C/H		
Check piston pin bearing	C	C/H	C	C/H		
Replace the crankshaft main bearings				C/H		
Replace the conrod bearings		C		C/H		
Check the entire transmission, the shift mechanism and bearings		C		C/H		
Complete maintenance of fork	C		C	H	C/H	
Complete maintenance of shock absorber				C		C/H
Clean and grease steering head bearings and gasket elements					C/H	
Replace the sealing cup for the foot brake cylinder	C	C/H	C	C/H		
Replace the glass-fiber yarn filling in the silencer	C	C/H	C	C/H		
Treat electric contacts and switches with contact grease					C/H	
Change break fluid	C	C/H	C	C/H	C/H	
Change the hydraulic clutch oil					C/H	

C = FOR COMPETITIVE OFFROAD RACING (COMPETITION)

H = FOR OFFROAD HOBBY USE

**Note:** If the inspection establishes that permissible tolerances are exceeded, the respective components must be replaced.

<b>125 EXC/EXC SIX DAYS, 200 XC/XC-W/EXC 2007</b>	before each start	after every cleaning	for cross country use	once a year
<b>IMPORTANT CHECKS AND MAINTENANCE TO BE CARRIED OUT BY THE RIDER</b>				
Check gear box oil level	●			
Check brake fluid level	●			
Check brake pads for wear	●			
Check lights for function	●			
Check horn for function	●			
Lubricate and adjust cables and nipples		●		
Bleed fork legs regularly			●	
Remove and clean dust bellows regularly			●	
Clean and lubricate chain, check tension and adjust if necessary		●	●	
Clean air filter and filter box		●	●	
Check tires for pressure and wear	●			
Check cooling liquid level	●			
Check fuel lines for leaks	●			
Empty and clean float chamber		●		●
Remove, clean and oil the throttle slide		●		
Check all control elements for smooth operation	●			
Check brake performance	●	●		
Treat blank metal parts (with the exception of brake and exhaust systems) with wax-based anti corrosion agent		●		
Treat ignition and steering locks and light switches with contact spray		●		
Check tightness of screws, nuts and hose clamps regularly				●



## PERIODIC MAINTENANCE SCHEDULE 2007

125 SX/SXS, 144 SX 2007

**A CLEAN MOTORCYCLE CAN BE CHECKED MORE QUICKLY WHICH SAVES MONEY**

		Before each race	1st service after 10 hours	every 20 hours	every 40 hours	at least once a year
<b>ENGINE</b>	Check gear box oil level			●		
	Change gear box oil	●	●		●	●
	Check spark plugs, adjust distance between electrodes		●	●		
	Renew spark plugs	●			●	
	Clean the spark-plug connector and check for a tight fit	●		●	●	
	Check the screws on the kick starter and shift lever for a tight fit	●		●	●	
<b>CARBURETOR</b>	Check the carburetor connection boot and intake flange for cracks or leaks	●			●	●
	Check idle speed setting	●	●		●	●
	Check that vent hoses are not damaged or bent	●	●		●	●
<b>ADD-ON-PARTS</b>	Check cooling system for leaks, check quantity of antifreeze	●	●		●	●
	Check exhaust system for leaks and fitment	●		●	●	
	Check cables for damage, smooth operation, bends; adjust and lubricate	●	●		●	
	Check the fluid level in the master cylinder of the hydraulic clutch	●	●	●	●	
	Clean air filter and filter box	●	●	●	●	●
	Check electric wires for damage and bends	●			●	
	Check headlamp setting	●			●	
	Check function of electric systems (low beam, high beam, break light, indicator, indicator lamps, speedometer illumination, horn, emergency OFF switch or button)	●	●		●	
<b>BRAKES</b>	Check brake fluid level, lining thickness, brake lining	●	●		●	
	Check brake lines for damage and leaks	●	●		●	
	Check/adjust the function, smooth operation and free travel of the hand/foot brake lever	●	●		●	
	Check the screws and guide bolts on the brake system for a tight fit	●	●		●	
<b>CHASSIS</b>	Check shock absorber and fork for leaks and function	●	●	●	●	
	Clean dust bellows	●		●	●	
	Bleed fork legs	●		●	●	
	Check swing arm bearings	●			●	
	Check/adjust steering head bearings	●	●		●	
	Check tightness of all chassis screws (triple clamps, fork leg axle passage axle nuts and screws, swing arm bearings, shock absorber)	●	●		●	
<b>WHEELS</b>	Check spoke tension and rim joint	●	●	●	●	
	Check tires and air pressure	●	●	●	●	
	Check chain, rear sprockets and chain guides for wear, fitment and tension	●	●	●	●	
	Lubricate chain, Clean and grease the adjusting screws on the chain tensioner	●	●	●	●	
	Check clearance of wheel bearings	●	●		●	

The kilometer reading for inspection intervals should not exceed 5 hours.

Maintenance work performed by your authorized KTM workshop is not a substitute for care and maintenance by the driver!

<b>125 SX/SXS, 144 SX 2007</b>						
<b>IMPORTANT SERVICE WORK THAT MUST BE PERFORMED BY AN AUTHORIZED KTM WORKSHOP UNDER A SEPARATE ORDER</b>	<b>Every 20 hours</b>	<b>Every 40 hours</b>	<b>Every 60 hours</b>	<b>Every 80 hours</b>	<b>At least once a year</b>	<b>Every 2 years</b>
Clean and adjust carburetor					●	
Replace the throttle slide, jet needle, float needle valve, needle nozzle				●		
Check the reed-type intake valve for wear	●	●	●	●		
Check the wear on the clutch disks and length of the clutch springs	●	●	●	●		
Check the cylinder and piston for wear	●	●	●	●		
Check function of exhaust control	●	●		●		
Check piston pin bearing	●	●	●	●		
Replace the crankshaft main bearings				●		
Replace the conrod bearings		●		●		
Check the entire transmission, the shift mechanism and bearings		●		●		
Complete maintenance of fork	●		●	●	●	
Complete maintenance of shock absorber				●		●
Clean and grease steering head bearings and gasket elements					●	
Replace the sealing cup for the foot brake cylinder	●	●	●	●		
Replace the glass-fiber yarn filling in the silencer	●	●	●	●		
Treat electric contacts and switches with contact grease					●	
Change brake fluid	●	●	●	●	●	
Change the hydraulic clutch oil					●	

**Note:** If the inspection establishes that permissible tolerances are exceeded, the respective components must be replaced.

<b>125 SX/SXS, 144 SX 2007</b>				
<b>IMPORTANT CHECKS AND MAINTENANCE TO BE CARRIED OUT BY THE RIDER</b>	<b>before each start</b>	<b>after every cleaning</b>	<b>for cross country use</b>	<b>once a year</b>
Check gear box oil level	●			
Check brake fluid level	●			
Check brake pads for wear	●			
Check lights for function	●			
Check horn for function	●			
Lubricate and adjust cables and nipples		●		
Bleed fork legs regularly			●	
Remove and clean dust bellows regularly			●	
Clean and lubricate chain, check tension and adjust if necessary		●	●	
Clean air filter and filter box		●	●	
Check tires for pressure and wear	●			
Check cooling liquid level	●			
Check fuel lines for leaks	●			
Empty and clean float chamber		●		●
Remove, clean and oil the throttle slide		●		
Check all control elements for smooth operation	●			
Check brake performance	●	●		
Treat blank metal parts (with the exception of brake and exhaust systems) with wax-based anti corrosion agent		●		
Treat ignition and steering locks and light switches with contact spray		●		
Check tightness of screws, nuts and hose clamps regularly				●



## PERIODIC MAINTENANCE SCHEDULE 2008

### 125 EXC/EXC SIX DAYS, 200 XC/XC-W/EXC 2008

**A CLEAN MOTORCYCLE CAN BE CHECKED MORE QUICKLY WHICH SAVES MONEY**

		Before each race	1st service after 10 hours	every 20 hours	every 40 hours	at least once a year
<b>ENGINE</b>	Check gear box oil level			●		
	Change gear box oil	●	●		●	●
	Check spark plugs, adjust distance between electrodes		●	●		
	Renew spark plugs	●			●	
	Clean the spark-plug connector and check for a tight fit	●		●	●	
	Check the screws on the kick starter and shift lever for a tight fit	●		●	●	
<b>CARBURETOR</b>	Check the carburetor connection boot and intake flange for cracks or leaks	●			●	●
	Check idle speed setting	●	●		●	●
	Check that vent hoses are not damaged or bent	●	●		●	●
<b>ADD-ON-PARTS</b>	Check cooling system for leaks, check quantity of antifreeze	●	●		●	●
	Check exhaust system for leaks and fitment	●		●	●	
	Check cables for damage, smooth operation, bends; adjust and lubricate	●	●		●	
	Check the fluid level in the master cylinder of the hydraulic clutch	●	●	●	●	
	Clean air filter and filter box	●	●	●	●	●
	Check electric wires for damage and bends	●			●	
	Check headlamp setting	●			●	
	Check function of electric systems (low beam, high beam, break light, indicator, indicator lamps, speedometer illumination, horn, emergency OFF switch or button)	●	●		●	
<b>BRAKES</b>	Check brake fluid level, lining thickness, brake lining	●	●		●	
	Check brake lines for damage and leaks	●	●		●	
	Check/adjust the function, smooth operation and free travel of the hand/foot brake lever	●	●		●	
	Check the screws and guide bolts on the brake system for a tight fit	●	●		●	
<b>CHASSIS</b>	Check shock absorber and fork for leaks and function	●	●	●	●	
	Clean dust bellows	●		●	●	
	Bleed fork legs	●		●	●	
	Check swing arm bearings	●			●	
	Check/adjust steering head bearings	●	●		●	
	Check tightness of all chassis screws (triple clamps, fork leg axle passage axle nuts and screws, swing arm bearings, shock absorber)	●	●		●	
<b>WHEELS</b>	Check spoke tension and rim joint	●	●	●	●	
	Check tires and air pressure	●	●	●	●	
	Check chain, rear sprockets and chain guides for wear, fitment and tension	●	●	●	●	
	Lubricate chain, Clean and grease the adjusting screws on the chain tensioner	●	●	●	●	
	Check clearance of wheel bearings	●	●		●	

The kilometer reading for inspection intervals should not exceed 5 hours.

Maintenance work performed by your authorized KTM workshop is not a substitute for care and maintenance by the driver!

<b>125 EXC/EXC SIX DAYS, 200 XC/XC-W/EXC 2008</b>	Every 20 hours	Every 40 hours	Every 60 hours	Every 80 hours	At least once a year	Every 2 years
<b>IMPORTANT SERVICE WORK THAT MUST BE PERFORMED BY AN AUTHORIZED KTM WORKSHOP UNDER A SEPARATE ORDER</b>						
Clean and adjust carburetor					C/H	C/H
Replace the throttle slide, jet needle, float needle valve, needle nozzle				C/H		
Check the reed-type intake valve for wear	C	C/H	C	C/H		
Check the wear on the clutch disks and length of the clutch springs	C	C/H	C	C/H		
Check the cylinder and piston for wear	C	C/H	C	C/H		
Check function of exhaust control	C/H	C/H		C/H		
Check piston pin bearing	C	C/H	C	C/H		
Replace the crankshaft main bearings				C/H		
Replace the conrod bearings		C		C/H		
Check the entire transmission, the shift mechanism and bearings		C		C/H		
Complete maintenance of fork	C		C	H	C/H	
Complete maintenance of shock absorber				C		C/H
Clean and grease steering head bearings and gasket elements					C/H	
Replace the sealing cup for the foot brake cylinder	C	C/H	C	C/H		
Replace the glass-fiber yarn filling in the silencer	C	C/H	C	C/H		
Treat electric contacts and switches with contact grease					C/H	
Change break fluid	C	C/H	C	C/H	C/H	
Change the hydraulic clutch oil					C/H	

C = FOR COMPETITIVE OFFROAD RACING (COMPETITION)

H = FOR OFFROAD HOBBY USE

**Note:** If the inspection establishes that permissible tolerances are exceeded, the respective components must be replaced.

<b>125 EXC/EXC SIX DAYS, 200 XC/XC-W/EXC 2008</b>	before each start	after every cleaning	for cross country use	once a year
<b>IMPORTANT CHECKS AND MAINTENANCE TO BE CARRIED OUT BY THE RIDER</b>				
Check gear box oil level	●			
Check brake fluid level	●			
Check brake pads for wear	●			
Check lights for function	●			
Check horn for function	●			
Lubricate and adjust cables and nipples		●		
Bleed fork legs regularly			●	
Remove and clean dust bellows regularly			●	
Clean and lubricate chain, check tension and adjust if necessary		●	●	
Clean air filter and filter box		●	●	
Check tires for pressure and wear	●			
Check cooling liquid level	●			
Check fuel lines for leaks	●			
Empty and clean float chamber		●		●
Remove, clean and oil the throttle slide		●		
Check all control elements for smooth operation	●			
Check brake performance	●	●		
Treat blank metal parts (with the exception of brake and exhaust systems) with wax-based anti corrosion agent		●		
Treat ignition and steering locks and light switches with contact spray		●		
Check tightness of screws, nuts and hose clamps regularly				●



## PERIODIC MAINTENANCE SCHEDULE 2008

### 125/144 SX 2008

**A CLEAN MOTORCYCLE CAN BE CHECKED MORE QUICKLY WHICH SAVES MONEY**

		Before each race	1st service after 10 hours	every 20 hours	every 40 hours	at least once a year
<b>ENGINE</b>	Check gear box oil level			●		
	Change gear box oil	●	●		●	●
	Check spark plugs, adjust distance between electrodes		●	●		
	Renew spark plugs	●			●	
	Clean the spark-plug connector and check for a tight fit	●		●	●	
	Check the screws on the kick starter and shift lever for a tight fit	●		●	●	
<b>CARBURETOR</b>	Check the carburetor connection boot and intake flange for cracks or leaks	●			●	●
	Check idle speed setting	●	●		●	●
	Check that vent hoses are not damaged or bent	●	●		●	●
<b>ADD-ON-PARTS</b>	Check cooling system for leaks, check quantity of antifreeze	●	●		●	●
	Check exhaust system for leaks and fitment	●		●	●	
	Check cables for damage, smooth operation, bends; adjust and lubricate	●	●		●	
	Check the fluid level in the master cylinder of the hydraulic clutch	●	●	●	●	
	Clean air filter and filter box	●	●	●	●	●
	Check electric wires for damage and bends	●			●	
	Check headlamp setting	●			●	
	Check function of electric systems (low beam, high beam, break light, indicator, indicator lamps, speedometer illumination, horn, emergency OFF switch or button)	●	●		●	
<b>BRAKES</b>	Check brake fluid level, lining thickness, brake lining	●	●		●	
	Check brake lines for damage and leaks	●	●		●	
	Check/adjust the function, smooth operation and free travel of the hand/foot brake lever	●	●		●	
	Check the screws and guide bolts on the brake system for a tight fit	●	●		●	
<b>CHASSIS</b>	Check shock absorber and fork for leaks and function	●	●	●	●	
	Clean dust bellows	●		●	●	
	Bleed fork legs	●		●	●	
	Check swing arm bearings	●			●	
	Check/adjust steering head bearings	●	●		●	
	Check tightness of all chassis screws (triple clamps, fork leg axle passage axle nuts and screws, swing arm bearings, shock absorber)	●	●		●	
<b>WHEELS</b>	Check spoke tension and rim joint	●	●	●	●	
	Check tires and air pressure	●	●	●	●	
	Check chain, rear sprockets and chain guides for wear, fitment and tension	●	●	●	●	
	Lubricate chain, Clean and grease the adjusting screws on the chain tensioner	●	●	●	●	
	Check clearance of wheel bearings	●	●		●	

The kilometer reading for inspection intervals should not exceed 5 hours.

Maintenance work performed by your authorized KTM workshop is not a substitute for care and maintenance by the driver!

<b>125/144 SX 2008</b>						
<b>IMPORTANT SERVICE WORK THAT MUST BE PERFORMED BY AN AUTHORIZED KTM WORKSHOP UNDER A SEPARATE ORDER</b>	<b>Every 20 hours</b>	<b>Every 40 hours</b>	<b>Every 60 hours</b>	<b>Every 80 hours</b>	<b>At least once a year</b>	<b>Every 2 years</b>
Clean and adjust carburetor					●	
Replace the throttle slide, jet needle, float needle valve, needle nozzle				●		
Check the reed-type intake valve for wear	●	●	●	●		
Check the wear on the clutch disks and length of the clutch springs	●	●	●	●		
Check the cylinder and piston for wear	●	●	●	●		
Check function of exhaust control	●	●		●		
Check piston pin bearing	●	●	●	●		
Replace the crankshaft main bearings				●		
Replace the conrod bearings		●		●		
Check the entire transmission, the shift mechanism and bearings		●		●		
Complete maintenance of fork	●		●	●	●	
Complete maintenance of shock absorber				●		●
Clean and grease steering head bearings and gasket elements					●	
Replace the sealing cup for the foot brake cylinder	●	●	●	●		
Replace the glass-fiber yarn filling in the silencer	●	●	●	●		
Treat electric contacts and switches with contact grease					●	
Change break fluid	●	●	●	●	●	
Change the hydraulic clutch oil					●	

**Note:** If the inspection establishes that permissible tolerances are exceeded, the respective components must be replaced.

<b>125/144 SX 2008</b>				
<b>IMPORTANT CHECKS AND MAINTENANCE TO BE CARRIED OUT BY THE RIDER</b>	<b>before each start</b>	<b>after every cleaning</b>	<b>for cross country use</b>	<b>once a year</b>
Check gear box oil level	●			
Check brake fluid level	●			
Check brake pads for wear	●			
Check lights for function	●			
Check horn for function	●			
Lubricate and adjust cables and nipples		●		
Bleed fork legs regularly			●	
Remove and clean dust bellows regularly			●	
Clean and lubricate chain, check tension and adjust if necessary		●	●	
Clean air filter and filter box		●	●	
Check tires for pressure and wear	●			
Check cooling liquid level	●			
Check fuel lines for leaks	●			
Empty and clean float chamber		●		●
Remove, clean and oil the throttle slide		●		
Check all control elements for smooth operation	●			
Check brake performance	●	●		
Treat blank metal parts (with the exception of brake and exhaust systems) with wax-based anti corrosion agent		●		
Treat ignition and steering locks and light switches with contact spray		●		
Check tightness of screws, nuts and hose clamps regularly				●





## PERIODIC MAINTENANCE SCHEDULE 2009

125/150 SX 2009		Before each race	1st service after 10 hours	every 20 hours	every 40 hours	at least once a year
<b>A CLEAN MOTORCYCLE CAN BE CHECKED MORE QUICKLY WHICH SAVES MONEY</b>						
<b>ENGINE</b>	Check gear box oil level			●		
	Change gear box oil	●	●		●	●
	Check spark plugs, adjust distance between electrodes		●	●		
	Renew spark plug	●			●	
	Clean the spark-plug connector and check for a tight fit	●		●	●	
	Check the screws on the kick starter and shift lever for a tight fit	●		●	●	
<b>CARBURETOR</b>	Check the carburetor connection boot and intake flange for cracks or leaks	●			●	●
	Check idle speed setting	●	●		●	●
	Check that vent hoses are not damaged or bent	●	●		●	●
<b>ADD-ON-PARTS</b>	Check cooling system for leaks, check quantity of antifreeze	●	●		●	●
	Check exhaust system for leaks and fitment	●		●	●	
	Check cables for damage, smooth operation, bends; adjust and lubricate	●	●		●	
	Check the fluid level in the master cylinder of the hydraulic clutch	●	●	●	●	
	Clean air filter and filter box	●	●	●	●	●
	Check electric wires for damage and bends	●			●	
	Check headlamp setting	●			●	
	Check function of electric systems (low beam, high beam, break light, indicator, indicator lamps, speedometer illumination, horn, emergency OFF switch or button)	●	●		●	
<b>BRAKES</b>	Check brake fluid level, lining thickness, brake lining	●	●		●	
	Check brake lines for damage and leaks	●	●		●	
	Check/adjust the function, smooth operation and free travel of the hand/foot brake lever	●	●		●	
	Check the screws and guide bolts on the brake system for a tight fit	●	●		●	
<b>CHASSIS</b>	Check shock absorber and fork for leaks and function	●	●	●	●	
	Clean dust bellows	●		●	●	
	Bleed fork legs	●		●	●	
	Check swing arm bearings	●			●	
	Check/adjust steering head bearings	●	●		●	
	Check tightness of all chassis screws (triple clamps, fork leg axle passage axle nuts and screws, swing arm bearings, shock absorber)	●	●		●	
<b>WHEELS</b>	Check spoke tension and rim joint	●	●	●	●	
	Check tires and air pressure	●	●	●	●	
	Check chain, rear sprockets and chain guides for wear, fitment and tension	●	●	●	●	
	Lubricate chain, Clean and grease the adjusting screws on the chain tensioner	●	●	●	●	
	Check clearance of wheel bearings	●	●		●	

The kilometer reading for inspection intervals should not exceed 5 hours.

Maintenance work performed by your authorized KTM workshop is not a substitute for care and maintenance by the driver!

125/150 SX 2009	Every 20 hours	Every 40 hours	Every 60 hours	Every 80 hours	At least once a year	Every 2 years
<b>IMPORTANT SERVICE WORK THAT MUST BE PERFORMED BY AN AUTHORIZED KTM WORKSHOP UNDER A SEPARATE ORDER</b>						
Clean and adjust carburetor					●	
Replace the throttle slide, jet needle, float needle valve, needle nozzle				●		
Check the reed-type intake valve for wear	●	●	●	●		
Check the wear on the clutch disks and length of the clutch springs	●	●	●	●		
Check the cylinder and piston for wear	●	●	●	●		
Check function of exhaust control	●	●		●		
Check piston pin bearing	●	●	●	●		
Replace the crankshaft main bearings				●		
Replace the conrod bearings		●		●		
Check the entire transmission, the shift mechanism and bearings		●		●		
Complete maintenance of fork	●		●	●	●	
Complete maintenance of shock absorber				●		●
Clean and grease steering head bearings and gasket elements					●	
Replace the sealing cup for the foot brake cylinder	●	●	●	●		
Replace the glass-fiber yarn filling in the silencer	●	●	●	●		
Treat electric contacts and switches with contact grease					●	
Change break fluid	●	●	●	●	●	
Change the hydraulic clutch oil					●	

**Note:** If the inspection establishes that permissible tolerances are exceeded, the respective components must be replaced.

125/150 SX 2009	before each start	after every cleaning for cross country use	once a year
<b>IMPORTANT CHECKS AND MAINTENANCE TO BE CARRIED OUT BY THE RIDER</b>			
Check gear box oil level	●		
Check brake fluid level	●		
Check brake pads for wear	●		
Check lights for function	●		
Check horn for function	●		
Lubricate and adjust cables and nipples		●	
Bleed fork legs regularly			●
Remove and clean dust bellows regularly			●
Clean and lubricate chain, check tension and adjust if necessary		●	●
Clean air filter and filter box		●	●
Check tires for pressure and wear	●		
Check cooling liquid level	●		
Check fuel lines for leaks	●		
Empty and clean float chamber		●	●
Remove, clean and oil the throttle slide		●	
Check all control elements for smooth operation	●		
Check brake performance	●	●	
Treat blank metal parts (with the exception of brake and exhaust systems) with wax-based anti corrosion agent		●	
Treat ignition and steering locks and light switches with contact spray		●	
Check tightness of screws, nuts and hose clamps regularly			●



## PERIODIC MAINTENANCE SCHEDULE 2009

125 EXC/EXC SIX DAYS, 200 XC/XC-W/EXC 2009		Before each race	1st service after 10 hours	every 20 hours	every 40 hours	at least once a year
<b>A CLEAN MOTORCYCLE CAN BE CHECKED MORE QUICKLY WHICH SAVES MONEY</b>						
<b>ENGINE</b>	Check gear box oil level			●		
	Change gear box oil	●	●		●	●
	Check spark plugs, adjust distance between electrodes		●	●		
	Renew spark plugs	●			●	
	Clean the spark-plug connector and check for a tight fit	●		●	●	
	Check the screws on the kick starter and shift lever for a tight fit	●		●	●	
<b>CARBURETOR</b>	Check the carburetor connection boot and intake flange for cracks or leaks	●			●	●
	Check idle speed setting	●	●		●	●
	Check that vent hoses are not damaged or bent	●	●		●	●
<b>ADD-ON-PARTS</b>	Check cooling system for leaks, check quantity of antifreeze	●	●		●	●
	Check exhaust system for leaks and fitment	●		●	●	
	Check cables for damage, smooth operation, bends; adjust and lubricate	●	●		●	
	Check the fluid level in the master cylinder of the hydraulic clutch	●	●	●	●	
	Clean air filter and filter box	●	●	●	●	●
	Check electric wires for damage and bends	●			●	
	Check headlamp setting	●			●	
	Check function of electric systems (low beam, high beam, break light, indicator, indicator lamps, speedometer illumination, horn, emergency OFF switch or button)	●	●		●	
<b>BRAKES</b>	Check brake fluid level, lining thickness, brake lining	●	●		●	
	Check brake lines for damage and leaks	●	●		●	
	Check/adjust the function, smooth operation and free travel of the hand/foot brake lever	●	●		●	
	Check the screws and guide bolts on the brake system for a tight fit	●	●		●	
<b>CHASSIS</b>	Check shock absorber and fork for leaks and function	●	●	●	●	
	Clean dust bellows	●		●	●	
	Bleed fork legs	●		●	●	
	Check swing arm bearings	●			●	
	Check/adjust steering head bearings	●	●		●	
	Check tightness of all chassis screws (triple clamps, fork leg axle passage axle nuts and screws, swing arm bearings, shock absorber)	●	●		●	
<b>WHEELS</b>	Check spoke tension and rim joint	●	●	●	●	
	Check tires and air pressure	●	●	●	●	
	Check chain, rear sprockets and chain guides for wear, fitment and tension	●	●	●	●	
	Lubricate chain, Clean and grease the adjusting screws on the chain tensioner	●	●	●	●	
	Check clearance of wheel bearings	●	●		●	

The kilometer reading for inspection intervals should not exceed 5 hours.

Maintenance work performed by your authorized KTM workshop is not a substitute for care and maintenance by the driver!

125 EXC/EXC SIX DAYS, 200 XC/XC-W/EXC 2009	Every 20 hours	Every 40 hours	Every 60 hours	Every 80 hours	At least once a year	Every 2 years
<b>IMPORTANT SERVICE WORK THAT MUST BE PERFORMED BY AN AUTHORIZED KTM WORKSHOP UNDER A SEPARATE ORDER</b>						
Clean and adjust carburetor					C/H	C/H
Replace the throttle slide, jet needle, float needle valve, needle nozzle				C/H		
Check the reed-type intake valve for wear	C	C/H	C	C/H		
Check the wear on the clutch disks and length of the clutch springs	C	C/H	C	C/H		
Check the cylinder and piston for wear	C	C/H	C	C/H		
Check function of exhaust control	C/H	C/H		C/H		
Check piston pin bearing	C	C/H	C	C/H		
Replace the crankshaft main bearings				C/H		
Replace the conrod bearings		C		C/H		
Check the entire transmission, the shift mechanism and bearings		C		C/H		
Complete maintenance of fork	C		C	H	C/H	
Complete maintenance of shock absorber				C		C/H
Clean and grease steering head bearings and gasket elements					C/H	
Replace the sealing cup for the foot brake cylinder	C	C/H	C	C/H		
Replace the glass-fiber yarn filling in the silencer	C	C/H	C	C/H		
Treat electric contacts and switches with contact grease					C/H	
Change break fluid	C	C/H	C	C/H	C/H	
Change the hydraulic clutch oil					C/H	

C = FOR COMPETITIVE OFFROAD RACING (COMPETITION)

H = FOR OFFROAD HOBBY USE

**Note:** If the inspection establishes that permissible tolerances are exceeded, the respective components must be replaced.

125 EXC/EXC SIX DAYS, 200 XC/XC-W/EXC 2009	before each start	after every cleaning	for cross country use	once a year
<b>IMPORTANT CHECKS AND MAINTENANCE TO BE CARRIED OUT BY THE RIDER</b>				
Check gear box oil level	●			
Check brake fluid level	●			
Check brake pads for wear	●			
Check lights for function	●			
Check horn for function	●			
Lubricate and adjust cables and nipples		●		
Bleed fork legs regularly			●	
Remove and clean dust bellows regularly			●	
Clean and lubricate chain, check tension and adjust if necessary		●	●	
Clean air filter and filter box		●	●	
Check tires for pressure and wear	●			
Check cooling liquid level	●			
Check fuel lines for leaks	●			
Empty and clean float chamber		●		●
Remove, clean and oil the throttle slide		●		
Check all control elements for smooth operation	●			
Check brake performance	●	●		
Treat blank metal parts (with the exception of brake and exhaust systems) with wax-based anti corrosion agent		●		
Treat ignition and steering locks and light switches with contact spray		●		
Check tightness of screws, nuts and hose clamps regularly				●



## PERIODIC MAINTENANCE SCHEDULE 125/150 SX 2010

### Important maintenance work that must be done in an authorized KTM workshop

		S10N	S20A	S40A
Engine	Check the gear oil level.		•	•
	Change the gear oil.	•		•
	Check spark plug and replace if required.	•	•	•
	Clean the spark plug connectors and check for tightness.		•	•
	Check that the screws in the shift lever and the kickstarter are tight.	•	•	•
	Check the engine mounting screws for tightness.	•	•	•
Carburetor	Check intake flange and carburetor connection boot for cracks and leakage.	•		•
	Check idle.	•		•
	Check vent hoses for damage and routing without sharp bends.	•		•
Attachments	Check the cooling system for leakage.	•		•
	Check the antifreeze and coolant level.	•		•
	Check the exhaust system for leakage and looseness.		•	•
	Check the cables for damage, smooth operation and routing without sharp bends.	•	•	•
	Check the fluid level of the hydraulic clutch.	•	•	•
	Clean the air filter.	•	•	•
	Check the cables for damage and routing without sharp bends.	•		•
Brakes	Check the front brake linings.	•		•
	Check the rear brake linings.	•		•
	Check the brake discs.	•		•
	Check the front brake fluid level.	•	•	•
	Check the rear brake fluid level.	•	•	•
	Check the brake lines for damage and leakage.	•		•
	Check the free travel of the hand brake lever.	•	•	•
	Check the free play of the foot brake lever.	•	•	•
	Check the brake system function.	•	•	•
Check the screws and guide bolts of the brake system for tightness.	•	•	•	
Chassis	Check the shock absorber and fork for leakage and functioning.	•	•	•
	Clean the dust boots of the fork legs.	•	•	•
	Bleed the fork legs.	•	•	•
	Check the swingarm bearing.	•		•
	Check the frame and swingarm for damage.	•		•
	Check the play of the steering head bearing.	•		•
	Check all screws to see if they are tight.	•		•
Wheels	Check the spoke tension.	•	•	•
	Check the wheel hubs for damage.	•	•	•
	Check rim run-out.	•	•	•
	Check the tire condition.	•	•	•
	Check the tire air pressure.	•	•	•
	Check chain wear.	•	•	•
	Check the chain tension.	•	•	•
	Clean the chain.	•	•	•
	Check the wheel bearing for play.	•		•
Clean and grease the adjusting screws of chain adjuster.	•	•	•	

**S10N:** Once after 10 service hours - corresponds to about 70 liters of fuel (18.5 US gal)

**S20A:** Every 20 service hours - corresponds to about 140 liters of fuel (37 US gal)

**S40A:** Every 40 service hours - corresponds to about 280 liters of fuel (74 US gal) / after a race

**Important maintenance work to be carried out by an authorized KTM workshop (as additional order)**

	S10A	S20N	S20A	S30A	S40A	S80A	J1A
Check/set the carburetor components.						•	
Check the intake diaphragm.			•		•	•	
Check the clutch lining discs.			•		•	•	
Check the length of the clutch springs.			•		•	•	
Check the cylinder and piston.			•		•	•	
Check the seating of the piston pin.			•		•	•	
Check exhaust control for functioning and smooth operation, clean.			•		•	•	
Change the crankshaft main bearing.						•	
Change the conrod bearing.					•	•	
Fully check the transmission.					•	•	
Check the shift mechanism.					•	•	
Conduct a major fork service.				•			
Conduct a minor fork service.	•		•	•	•	•	
Perform a shock absorber service.		•			•	•	
Grease the steering head bearing.							•
Change the foot brake cylinder seals.					•	•	
Change the glass fiber yarn filling of the main silencer.			•		•	•	
Change the hydraulic clutch fluid.							•
Change the front brake fluid.							•
Change the rear brake fluid.							•
Treat electric contacts with contact spray.							•

**S10A:** Every 10 service hours - corresponds to about 70 liters of fuel (18,5 US gal)

**S20N:** Once after 20 service hours - corresponds to about 140 liters of fuel (37 US gal)

**S20A:** Every 20 service hours - corresponds to about 140 liters of fuel (37 US gal)

**S30A:** Every 30 service hours - corresponds to about 210 liters of fuel (55.5 US gal)

**S40A:** Every 40 service hours - corresponds to about 280 liters of fuel (74 US gal)

**S80A:** Every 80 service hours - corresponds to about 560 liters of fuel (148 US gal)

**J1A:** annually

**Important checks and maintenance work to be carried out by the rider**

	NB1A
Check the gear oil level.	•
Check the front brake fluid level.	•
Check the rear brake fluid level.	•
Check the front brake linings.	•
Check the rear brake linings.	•
Check and adjust the cables.	•
Bleed the fork legs.	•
Clean the dust boots of the fork legs.	•
Clean the chain.	•
Check the chain tension.	•
Check chain wear.	•
Check the rear sprocket/engine sprocket for wear.	•
Clean the air filter.	•
Check the tire air pressure.	•
Check the tire condition.	•
Check the coolant level.	•
Empty the carburetor float chamber.	•
Check all controls for smooth operation.	•
Check braking.	•
Check all screws, nuts and hose clamps regularly for tightness.	•

**NB1A:** Depending on conditions of use according to requirements.





# PERIODIC MAINTENANCE SCHEDULE 125/200 EXC, 150/200 XC(-W) 2010

## Important maintenance work to be carried out by an authorized KTM workshop

		S10N	S20A	S40A
Engine	Check the gear oil level.		•	•
	Change the gear oil.	•		•
	Check spark plug and replace if required.	•	•	•
	Clean the spark plug connectors and check for tightness.		•	•
	Check that the screws in the shift lever and the kickstarter are tight.	•	•	•
	Check the engine mounting screws for tightness.	•	•	•
Carburetor	Check intake flange and carburetor connection boot for cracks and leakage.	•		•
	Check the idle.	•		•
	Check the vent hoses for damage and routing without sharp bends.	•		•
Attachments	Check the cooling system for leakage.	•		•
	Check the antifreeze and coolant level.	•		•
	Check the exhaust system for leakage and looseness.		•	•
	Check the throttle cables for damage, smooth operation and routing without sharp bends.	•	•	•
	Check the fluid level of the hydraulic clutch.	•	•	•
	Clean the air filter.	•	•	•
	Check the cables for damage and routing without sharp bends.	•		•
	Check that the electrical equipment is functioning properly.	•	•	•
	Check the headlight setting. (EXC, EXC SIX DAYS)	•	•	•
Brakes	Check the front brake linings.	•		•
	Check the rear brake linings.	•		•
	Check the brake discs.	•		•
	Check the front brake fluid level.	•	•	•
	Check the rear brake fluid level.	•	•	•
	Check the brake lines for damage and leakage.	•		•
	Check the free travel of the hand brake lever.	•	•	•
	Check the free travel of the foot brake lever.	•	•	•
	Check that the brake system is functioning properly.	•	•	•
	Check the screws and guide bolts of the brake system for tightness.	•	•	•
Chassis	Check the shock absorber and fork for leakage and functioning.	•	•	•
	Clean the dust boots of the fork legs.	•	•	•
	Bleed the fork legs.	•	•	•
	Check the frame and swingarm for damage.	•		•
	Check the swingarm bearing.	•		•
	Check the play of the steering head bearing.	•		•
	Check all screws to see if they are tight.	•		•
Wheels	Check the spoke tension.	•	•	•
	Check the wheel hubs for damage.	•	•	•
	Check the rim run-out.	•	•	•
	Check the tire condition.	•	•	•
	Check the tire air pressure.	•	•	•
	Check chain wear.	•	•	•
	Check the chain tension.	•	•	•
	Clean the chain.	•	•	•
	Check the wheel bearing for play.	•		•
	Clean and grease the adjusting screws of the chain adjuster.	•	•	•

**S10N:** once after 10 operating hours

**S20A:** every 20 operating hours

**S40A:** every 40 operating hours/after every race

**Important maintenance work to be carried out by an authorized KTM workshop (as additional order)**

	Competition use				Hobby use				S10A	S20N	S30A	J1A
	S10A	S20A	S40A	S80A	S20A	S40A	S60A	S80A				
Perform a fork service. (EXC, EXC SIX DAYS, XC-W)			•	•		•		•				
Perform a shock absorber service. (EXC, EXC SIX DAYS, XC-W)			•	•			•					
Conduct a minor fork service. (XC)									•		•	
Conduct a major fork service. (XC)											•	
Perform a shock absorber service. (XC)			•	•		•		•	•			
Grease the steering head bearing.												•
Change the foot brake cylinder seals.		•	•	•		•		•				
Change the glass fiber yarn filling of the main silencer.		•	•	•		•		•				
Change the hydraulic clutch fluid.												•
Change the front brake fluid.												•
Change the rear brake fluid.												•
Treat electric contacts with contact spray.												•
Check/set the carburetor components.			•	•				•				
Check the intake diaphragm.		•	•	•		•		•				
Check the clutch lining discs.		•	•	•		•		•				
Check the length of the clutch springs.		•	•	•		•		•				
Check the cylinder and piston.		•	•	•		•		•				
Check the seating of the piston pin.		•	•	•		•		•				



	Competition use				Hobby use				S10A	S20N	S30A	J1A
	S10A	S20A	S40A	S80A	S20A	S40A	S60A	S80A				
Check exhaust control for functioning and smooth operation, clean.	•	•	•	•	•	•	•	•				
Change the crankshaft main bearing.				•				•				
Change the conrod bearing.			•	•				•				
Check the transmission.			•	•				•				
Check the shift mechanism.			•	•				•				

**S10A:** every 10 operating hours

**S40A:** every 40 operating hours

**S20A:** every 20 operating hours

**S60A:** every 60 operating hours

**S80A:** every 80 operating hours

**S20N:** once after 20 operating hours

**S30A:** every 30 operating hours

**J1A:** annually

### Important checks and maintenance work to be carried out by the rider

	NB1A
Check the gear oil level.	•
Check the front brake fluid level.	•
Check the rear brake fluid level.	•
Check the front brake linings.	•
Check the rear brake linings.	•
Check and adjust the cables.	•
Bleed the fork legs.	•
Clean the dust boots of the fork legs.	•
Clean the chain.	•
Check the chain tension.	•
Check chain wear.	•
Check the rear sprocket/engine sprocket for wear.	•
Clean the air filter.	•
Check the tire air pressure.	•
Check the tire condition.	•
Check the coolant level.	•
Empty the carburetor float chamber.	•
Check all controls for smooth operation.	•
Check braking.	•
Check all screws, nuts and hose clamps regularly for tightness.	•

**NB1A:** Depending on conditions of use according to requirements.

**PartShark.com**  
**877-999-5686**

# WIRING DIAGRAMS

# 12

## INDEX

<b>MODEL 1999</b>	
125/200 EXC (EUROPE) .....	12-3
125/200 EGS (EUROPE) .....	12-4
125 EXC (USA) .....	12-6
200 EXC (USA) .....	12-7
<b>MODEL 2000</b>	
125/200 EXC (USA) .....	12-8
125/200 EXC (EUROPE) .....	12-9
125 EXE, SUPERMOTO .....	12-11
<b>MODEL 2001</b>	
125/200 EXC (EUROPE) .....	12-13
125/200 EXC (USA) .....	12-15
125 EXE, SUPERMOTO .....	12-11
<b>MODEL 2002</b>	
125/200 EXC (EUROPE) .....	12-13
125/200 EXC (USA) .....	12-15
<b>MODEL 2003</b>	
125/200 EXC (EUROPE/AUS) .....	12-16
125/200 EXC (USA) .....	12-18
<b>MODEL 2004</b>	
125/200 EXC (EUROPE) .....	12-19
125/200 EXC (USA) .....	12-20
125/200 SX .....	12-21
CABLE COLOURS .....	12-36
<b>MODEL 2005</b>	
125/200 EXC (EUROPE) .....	12-22
125/200 EXC (USA) .....	12-23
125 SX .....	12-24
CABLE COLOURS .....	12-36

**PartShark.com**  
**877-999-5686**

# WIRING DIAGRAMS

# 12

## INDEX

### MODEL 2006

125/200 EXC/EXC SIX DAYS .....	12-25
125 SX/SXS .....	12-24
200 XC .....	12-24
200 XC-W .....	12-26
CABLE COLOURS .....	12-36

### MODEL 2007

125/200 EXC/EXC SIX DAYS .....	12-27
125 SX/SXS .....	12-28
144 SX .....	12-28
200 XC .....	12-28
200 XC-W .....	12-29
CABLE COLOURS .....	12-36

### MODEL 2008

125/144 SX .....	12-30
200 XC USA, 200XC-W USA/ZA .....	12-31
125/200 EXC/EXC SIXDAYS EU/AUS .....	12-32
CABLE COLOURS .....	12-36

### MODEL 2009

125/150 SX .....	12-33
200 XC USA, 200 XC-W USA/ZA .....	12-34
125/200 EXC/EXC SIXDAYS EU/AUS .....	12-35
CABLE COLOURS .....	12-36

### MODEL 2010

125/150 SX .....	12-37
200 XC USA, 200 XC-W USA .....	12-38
125/200 EXC/EXC SIXDAYS EU/AUS .....	12-39
CABLE COLOURS .....	12-40

**PartShark.com**  
**877-999-5686**



Model I

125 / 200 EXC '99

Kabelstrangnummer  
vorne 503 11 075 500  
hinten 503 11 076 000

Kabelstrangbez  
vo 125/200 EXC '99  
hi 125-500 EXC '98

Änderungsstand

Zeichnungsnr  
2520XC99

Datum, Name  
22.06.98 KE

Land  
Europa

**Deutsch**

- 1 Scheinwerfer
- 2 Fernlichtkontrolle
- 3 Tachobeleuchtung
- 4 zum Kombischalter
- 5 Brennschichtsch vo
- 6 Brennschichtsch hi
- 7 Parallelverbinder
- 8 Schnarre
- 9 Brems-Schlußlicht
- 10 Zündspule
- 11 Zündkerze
- 12 Generator
- 13 2-pol Stecker
- 14 3-pol Stecker
- 15 4-pol Stecker
- 16 6-pol Stecker
- 17 Spannungsregler
- 18 CDI-Einheit

br braun  
ge gelb  
gr grau  
g grün  
o orange  
r rot  
s schwarz  
v violett  
w weiß

**Englisch**

- 1 headlight
- 2 high beam control
- 3 tachometer light
- 4 to combinat switch
- 5 stoplight switch f
- 6 stoplight switch r
- 7 parallel connector
- 8 horn
- 9 rear-stoplight
- 10 ignition coil
- 11 spark plug
- 12 generator
- 13 multip cont plug (2)
- 14 multip cont plug (3)
- 15 multip cont plug (4)
- 16 multip cont plug (6)
- 17 voltage limiter
- 18 CDI-unit

bl blue  
br brown  
ge yellow  
gr grey  
g green  
o orange  
r red  
s black  
v violet  
w white

**Italienisch**

- 1 fano
- 2 spia abbagliante
- 3 luz del tacometro
- 4 multicomando
- 5 int luce arresto ant
- 6 int luce arresto post
- 7 parallelo composto
- 8 clacson
- 9 fanal post di freno
- 10 bobina d'allumage
- 11 candela
- 12 dinamo
- 13 connettore a 2 poli
- 14 connettore a 3 poli
- 15 connettore a 4 poli
- 16 connettore a 6 poli
- 17 regol di tens
- 18 CDI-seatola

bl blu  
br marrone  
ge giallo  
gr grigio  
g verde  
o arancione  
r rosso  
s nero  
v violetto  
w bianco

**Französisch**

- 1 phare
- 2 témoin feu route
- 3 éclair comp vitesse
- 4 commodo
- 5 contact de stop av
- 6 contact de stop der
- 7 parallèle connecteur
- 8 klaxon
- 9 feu arr et de stop
- 10 bobine d'allumage
- 11 bougie
- 12 générateur
- 13 connect multiple (2)
- 14 connect multiple (3)
- 15 connect multiple (4)
- 16 connect multiple (6)
- 17 régulateur
- 18 boitier CDI

bl bleu  
br brun  
ge jaune  
gr gris  
g vert  
o orange  
r rouge  
s noir  
v violet  
w blanc

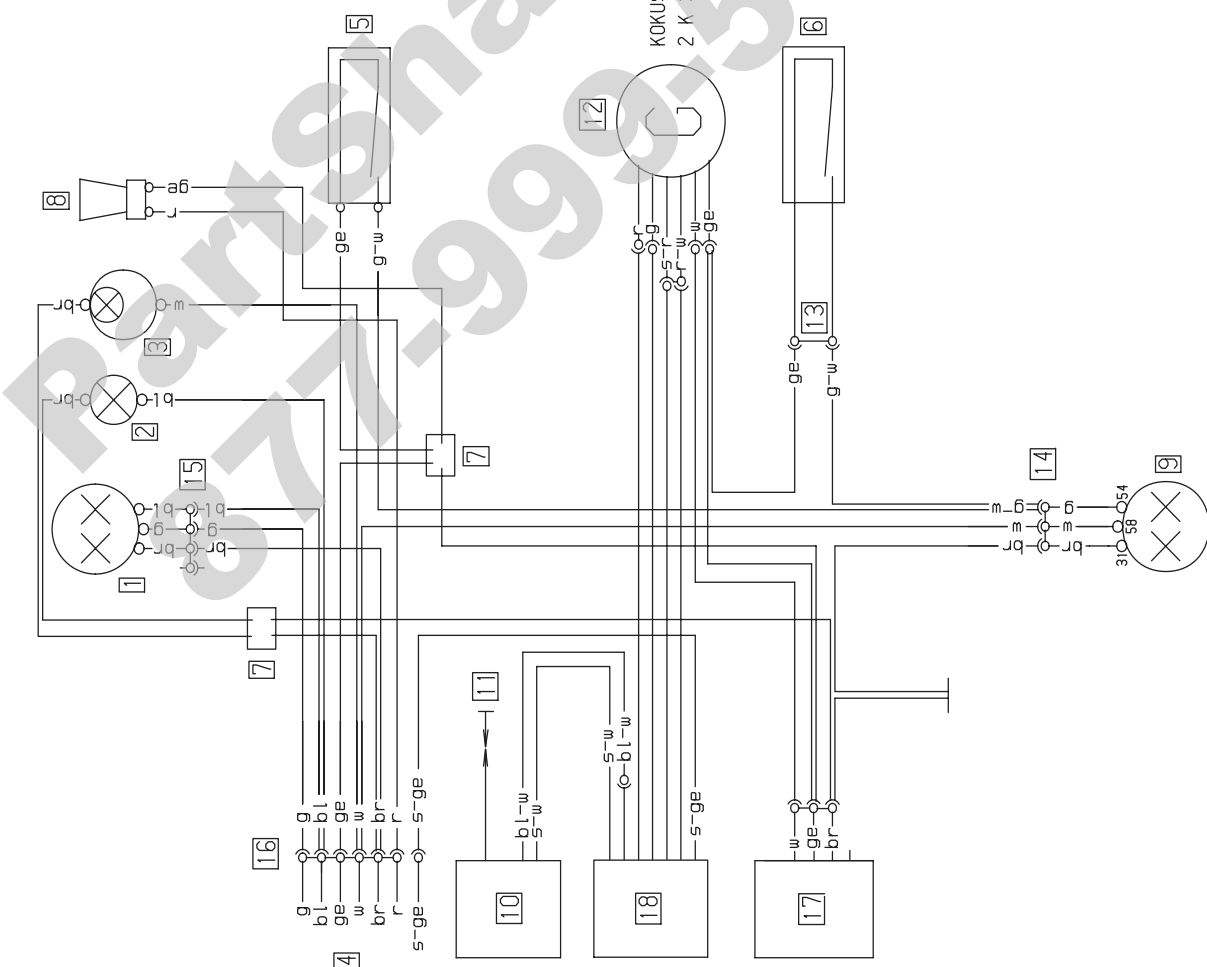

**Spanisch**

- 1 fano
- 2 control luces largas
- 3 luz tacometro
- 4 llave combinada
- 5 interr luces de freno del
- 6 interr luces de freno tras
- 7 conector paralelo
- 8 claxon
- 9 luz freno tras
- 10 bobina de encendido
- 11 bujia
- 12 generador
- 13 conector multiple (2)
- 14 conector multiple (3)
- 15 conector multiple (4)
- 16 conector multiple (6)
- 17 regulador de tension
- 18 unidad cdi

bl azul  
br marron  
ge amarillo  
gr gris  
g verde  
o naranja  
r rojo  
s negro  
v violeta  
w blanco

Kontaktbelegung - Lichtschalter (Typ CEV 9610)

	g	bl	ge	w	r	s	v	w
LIHT								br
Abblendl								
Fernlicht								
HUPE								
ZÜNDUNG AUS	5	2	1	3	6	4		

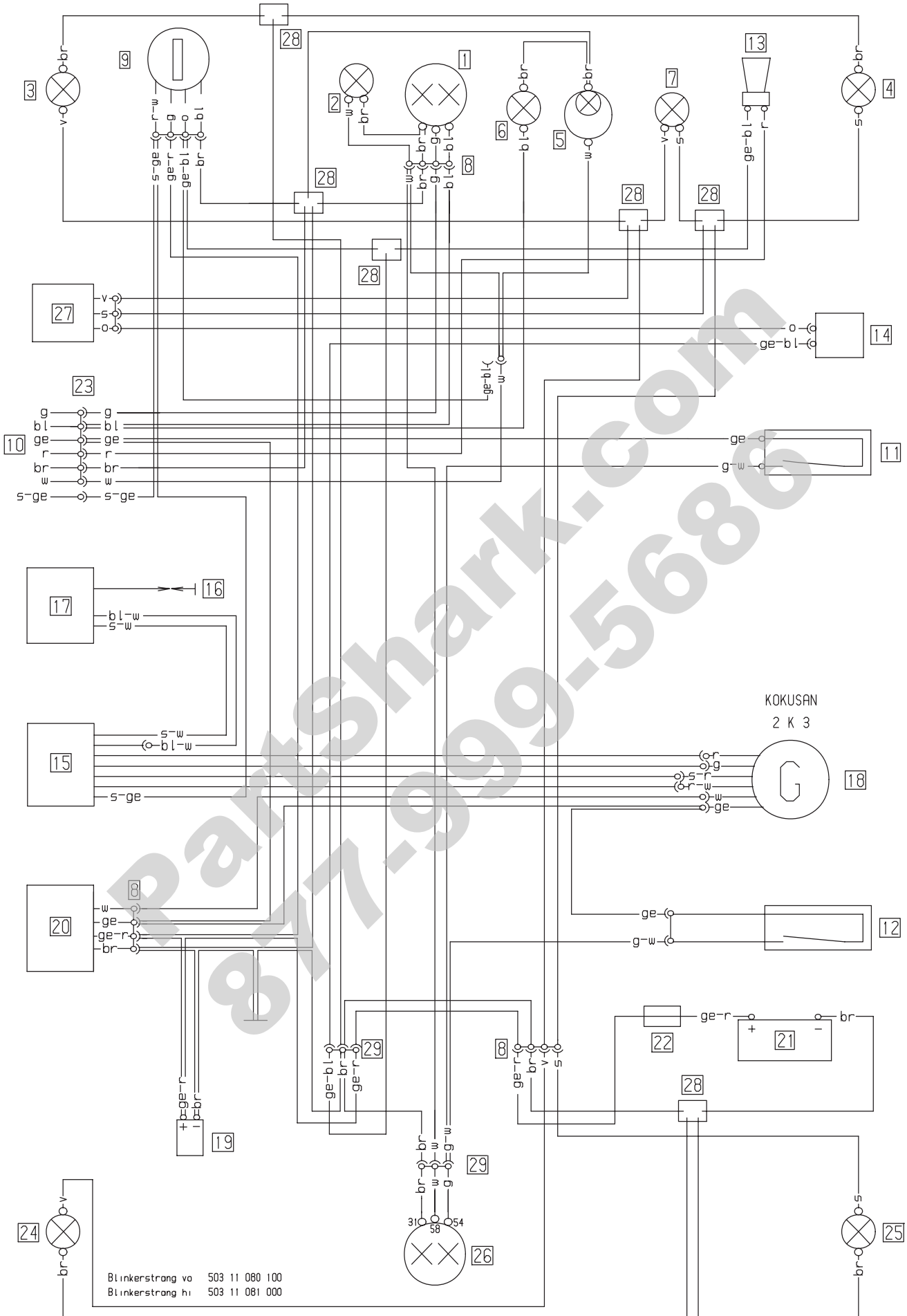



KTM 125/200 EGS 1999

Deutsch	Englisch	Italienisch	Französisch
1 Scheinwerfer	1 headlight	1 fardo	1 phare
2 Standlicht	2 parking light	2 luce di posizione	2 feu de position
3 Blinker li vo	3 turn indic left fr	3 lampegg ant sn	3 clignoteur av gauche
4 Blinker re vo	4 turn indic right fr	4 lampegg ant dx	4 clignoteur av droit
5 Tachobeleuchtung	5 speedometer light	5 luce di tachometro	5 éclair comp vitesse
6 Fernlichtkontrolle	6 high beam indicator	6 spia abbagliante	6 témoin feu route
7 Blinkerkontrolle	7 turn indicator	7 spia lampeggiatori	7 témoin de clignoteur
8 4-pol Stecker	8 multip cont plug (4)	8 connettore a 4 poli	8 connect multiple (4)
9 Zündschloß	9 ignition lock	9 accensione	9 contact d'allum
10 zum Kombischalter	10 to combinat switch	10 multicomando	10 commodo
11 Bremslichtsch vo	11 stoplight switch f	11 int luce arresto ant	11 contact de stop av
12 Bremslichtsch hi	12 stoplight switch r	12 int luce arresto post	12 contact Harr de stop
13 Horn	13 horn	13 clacson	13 klaxon
14 Blinkgeber	14 turn indicator	14 trasmett di lampeg	14 centrale clignot
15 CDI-Einheit	15 CDI-unit	15 CDI-seatola	15 boitier CDI
16 Zündkerze	16 spark plug	16 candela	16 bougie
17 Zündspule	17 ignition coil	17 bobina d'accens	17 bobine d'allumage
18 Generator	18 generator	18 dinamo	18 generateur
19 Kondensator	19 capacitor	19 condensatore	19 condensateur
20 Spannungsregler	20 voltage regulator	20 regol di tens	20 regulateur
21 Batterie 1 2Ah	21 battery 1 2Ah	21 batteria 1 2Ah	21 batterie 1 2Ah
22 Stecksicherung 10A	22 fuse 10A	22 fusibile 10A	22 fusible 10A
23 6-pol Stecker	23 multip cont plug (9)	23 connettore a 9 poli	23 connect multiple (9)
24 Blinker li hi	24 blinker left rear	24 lampegg post sn	24 clign arr gauche
25 Blinker re hi	25 blinker right rear	25 lampegg post dx	25 clign arr droite
26 Brems-Schlußlicht	26 rear-stoplight	26 fanal post di freno	26 feu arr et de stop
27 Blinkerschalter	27 blink switch	27 int lampeggiatori	27 contact d clignoteur
28 Parallelverbinder	28 parallel connector	28 parallelo composto	28 parallele connecteur
29 3-pol Stecker	29 multip cont plug (3)	29 connettore a 3 poli	29 connect multiple (9)

Art.-Nr. 3.206.062-E

Deutsch	Englisch	Italienisch	Französisch	Spanisch
bl blau	bl blue	bl blu	bl bleu	bl azul
br braun	br brown	br marrone	br brun	br marron
ge gelb	ge yellow	ge giallo	ge jaune	ge amarillo
gr grau	gr grey	gr grigio	gr gris	gr gris
g grün	g green	g verde	g vert	g verde
o orange	o orange	o arancione	o orange	o naranja
r rot	r red	r rosso	r rouge	r rojo
s schwarz	s black	s nero	s noir	s negro
v violett	v violet	v violetto	v violet	v violeta
w weiß	w white	w bianco	w blanc	w blanco

Spanisch
1 fardo
2 luz de posicion
3 interm izquierdo delantero
4 intermitente derecho delantero
5 luz tacometro
6 lampara aviso luces largas
7 lampara aviso intermitentes
8 conector multiple (4)
9 llave de contacto
10 interruptor combinado
11 interr luz de freno del
12 interr luz de fren tras
13 claxon
14 conjunto del intermintente
15 unidad cdi
16 bujia
17 bobina de encendido
18 generador
19 condensador
20 regulador de tension
21 bateria 12V 1 2Ah
22 fusible principal 10A
23 conector multiple (4)
24 intermitente izquierdo trasero
25 intermitente derecho trasero
26 luz de freno trasero
27 interuptor clignoteur
28 parallele connecteur
29 conector multiple (3)

Kontaktbelegung  
Zündschloß (Typ CEV 7-pol )

	1	2	3	4	5	6	7
PARK	•		•	•		•	
AUS			•	•			
EIN	•	•			•	•	
EIN	•	•			•	•	

Blinkerschalter

	s	o	v
←			
→		•	•
↔	•	•	

Kontaktbelegung -  
Lichtschalter (Typ CEV 9610)

	g	bl	ge	w	ge/s	r	br
LICHT	•						
Abblendl	•	•	•				
Fernlicht		•	•	•			
HUPE						•	•
ZÜNDUNG AUS					•		•
	5	2	1	3	6	4	

Repair manual KTM 125 / 144 / 150 / 200

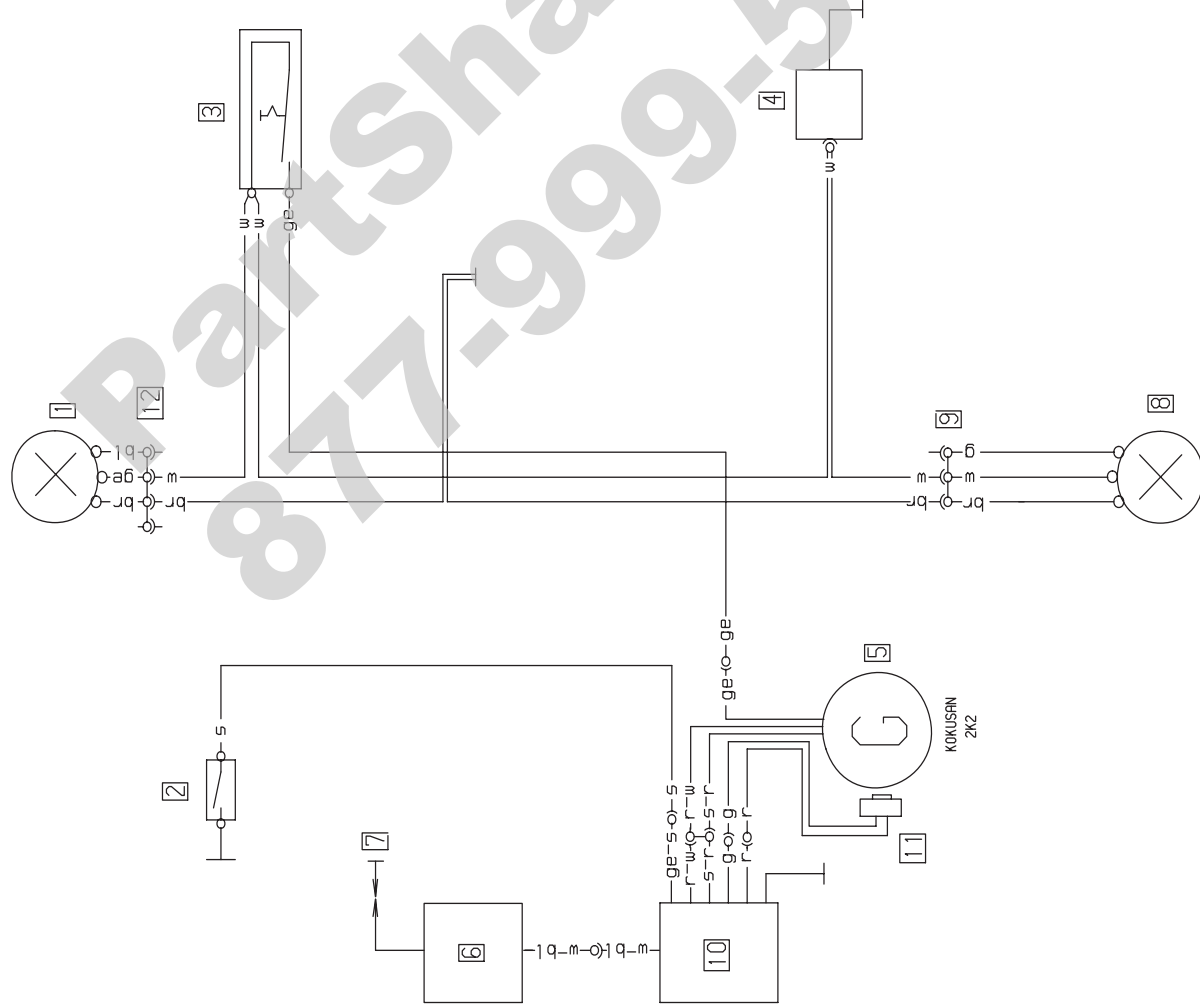

Deutsch	Englisch	Italianisch	Französisch
1 Scheinwerfer	1 headlight	1 fero	1 phare
2 Kurzschlußtaster	2 short-circuit button	2 interr cortocircuito	2 bouton d'arret
3 Lichtschalter	3 light switch	3 interr della luce	3 interr d' eclaireage
4 Spannungsbegrenzer	4 voltage limiter	4 regol di tens	4 regulateur
5 Generator	5 generator	5 dinamo	5 generateur
6 Zündspule	6 ignition coil	6 bobina d'accens	6 bobine d'allumage
7 Zündkerze	7 spark plug	7 candela	7 bougie
8 Schlußlicht	8 rear light	8 fanale posteriore	8 feu arriere
9 3-pol Stecker	9 multip cont plug (3)	9 connettore a 3 poli	9 connect multiple (3)
10 CDI-Einheit	10 CDI-unit	10 CDI-seatola	10 CDI-unite
11 Impulsgeber	11 pulser coil	11 distributore	11 generateur d'impuls
12 4-pol Stecker	12 multip cont plug (4)	12 connettore a 4 poli	12 connect multiple (4)
bl blau	bl blue	bl blu	bl bleu
br braun	br brown	br marrone	br brun
ge gelb	ge yellow	ge giallo	ge jaune
gr grün	gr grey	gr grigio	gr gris
g grün	g green	g verde	g vert
o orange	o orange	o arancione	o orange
r rot	r red	r rosso	r rouge
s schwarz	s black	s nero	s noir
v violett	v violet	v violetto	v violet
w weiß	w white	w bianco	w blanc

Spanisch
1 fero
2 interruptor a masa
3 interruptor d'luz
4 regulador de tension
5 generador
6 bobina de encendido
7 bujia
8 luz de trasera
9 conect multiple (3)
10 unidad cd
11 generador de impuls
12 conect multiple (4)
bl azul
br marron
ge amarillo
gr gris
g verde
o naranja
r rojo
s negro
v violeta
w blanco



**SERVICE**

Modell

# 200 EXC '98 '99

Land

## USA

Datum, Name

22.06.98 KE

Zeichnungsnr

200XCUSA

Änderungsstand

Kabelstrangbezeichnung

vo 200 EXC USA '98  
hi 125-380 EXC '98

**Deutsch**

- 1 Scheinwerfer
- 2 Kurzschlußtaster
- 3 Lichtschalter
- 4 Spannungsbegrenzer
- 5 Generator
- 6 Zündspule
- 7 Zündkerze
- 8 3-pol Stecker
- 10 CDI-Einheit
- 11 Impulsgeber
- 12 4-pol Stecker
- 13 CDI-Einheit

bl blau  
br braun  
ge gelb  
gr grau  
g grün  
o orange  
r rot  
s schwarz  
v violett  
w weiß

**Englisch**

- 1 headlight
- 2 short-circuit button
- 3 light switch
- 4 voltage limiter
- 5 generator
- 6 ignition coil
- 7 spark plug
- 8 rear light
- 9 multipoint plug (3)
- 10 CDI-unit
- 11 pulser coil
- 12 multipoint plug (4)
- 13 CDI-unit

bl blue  
br brown  
ge yellow  
gr grey  
g green  
o orange  
r red  
s black  
v violet  
w white

**Italienisch**

- 1 faro
- 2 interr cortocircuito
- 3 interr della luce
- 4 regol di tens
- 5 dinamo
- 6 bobina d'accensione
- 7 candela
- 8 fanale posteriore
- 9 connettore a 3 poli
- 10 CDI-seatola
- 11 distributore
- 12 connettore a 4 poli
- 13 CDI-seatola

bl blu  
br marrone  
ge giallo  
gr grigio  
g verde  
o arancione  
r rosso  
s nero  
v violetto  
w bianco

**Französisch**

- 1 phare
- 2 bouton d'arret
- 3 interr d'eclairage
- 4 regulateur
- 5 generateur
- 6 bobine d'allumage
- 7 bougie
- 8 feu arriere
- 9 connect multiple (3)
- 10 CDI-unite
- 11 generateur d'impuls
- 12 connect multiple (4)
- 13 boitier CDI

bl bleu  
br brun  
ge jaune  
gr gris  
g vert  
o orange  
r rouge  
s noir  
v violet  
w blanc

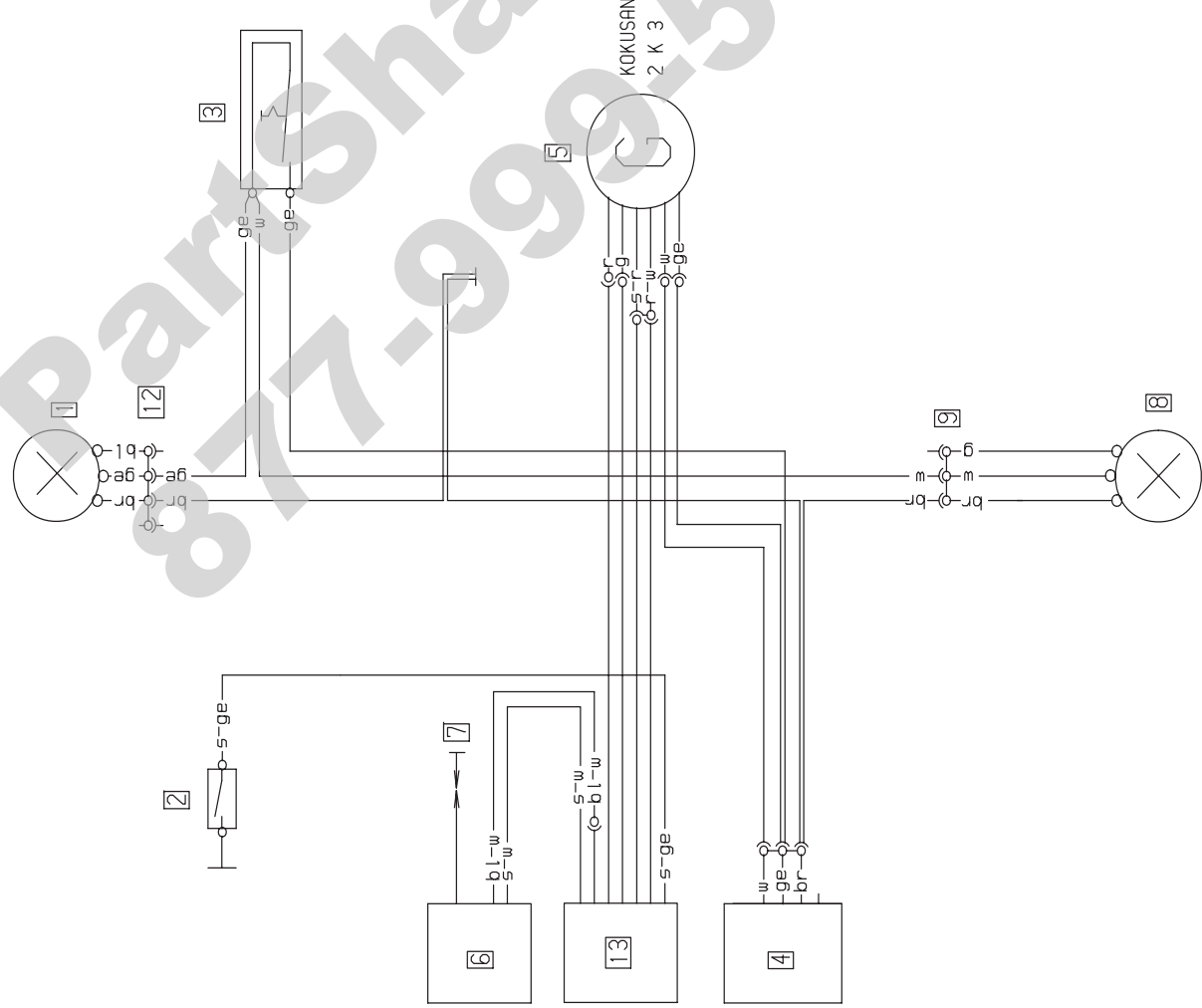

**KOKUSAN**  
2 K 3

**Spanisch**

- 1 faro
- 2 interruptor a masa
- 3 interruptor d'luz
- 4 regulador de tension
- 5 generador
- 6 bobina de encendido
- 7 bujia
- 8 luz de trasera
- 9 conect multiple (3)
- 10 unidad cdi
- 11 generador de impuls
- 12 conect multiple (4)
- 13 unidad cdi

bl azul  
br marron  
ge amarillo  
gr gris  
g verde  
o naranja  
r rojo  
s negro  
v violeta  
w blanco

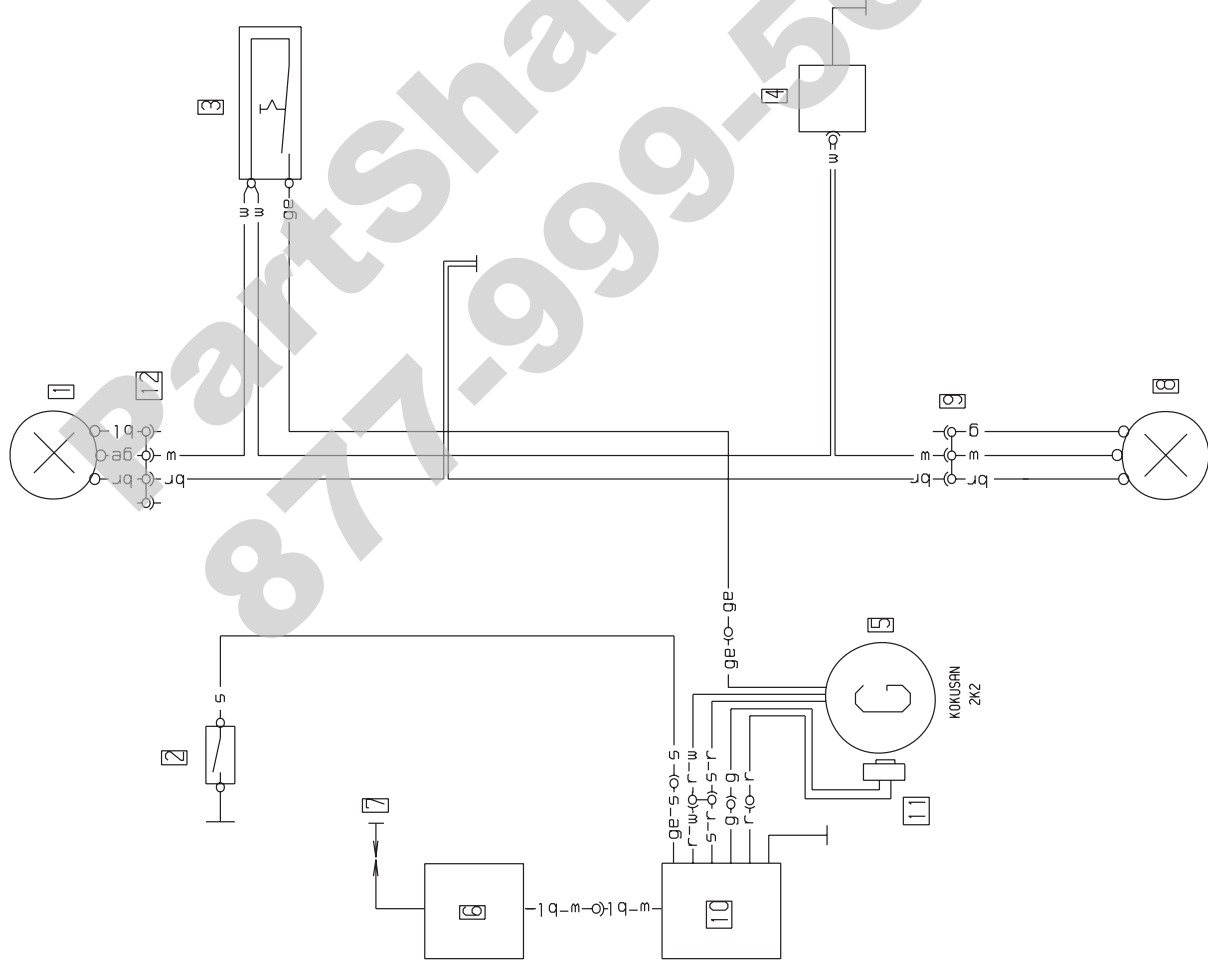

Deutsch	Englisch	Italienisch	Französisch
1 Scheinwerfer	1 headlight	1 foro	1 phare
2 Kurzschlußlöster	2 short-circuit button	2 interr cortocircuito	2 bouton d'arret
3 Lichtschalter	3 light switch	3 interr della luce	3 interr d' eclairoage
4 Spannungsbegrenzer	4 voltage limiter	4 regol di tens	4 regulateur
5 Generator	5 generator	5 dinamo	5 generateur
6 Zündspule	6 ignition coil	6 bobina d'accens	6 bobine d'allumage
7 Zündkerze	7 spark plug	7 candela	7 bougie
8 Schlußlicht	8 rearlight	8 fonale posteriore	8 feu arriere
9 3-pol Stecker	9 multi pin cont plug (3)	9 connettore a 3 poli	9 connect multiple (3)
10 CDI-Einheit	10 CDI-unit	10 CDI-seatola	10 CDI-unite
11 Impulsgeber	11 pulser coil	11 distributore	11 generateur d'impuls
12 4-pol Stecker	12 multi pin cont plug (4)	12 connettore a 4 poli	12 connect multiple (4)
bl blau	bl blue	bl blu	bl bleu
br braun	br brown	br marrone	br brun
ge gelb	ge yellow	ge giallo	ge jaune
gr grün	gr green	gr grigio	gr vert
o orange	o orange	o arancione	o orange
r rot	r red	r rosso	r rouge
s schwarz	s black	s nero	s noir
v violett	v violet	v violetto	v violet
w weiß	w white	w bianco	w blanc

Spanisch	
1 foro	1 foro
2 interruptor a masa	2 interruptor a masa
3 interruptor d' luz	3 interruptor d' luz
4 regulador de tension	4 regulador de tension
5 generador	5 generador
6 bobina de encendido	6 bobina de encendido
7 bujia	7 bujia
8 luz de trasera	8 luz de trasera
9 conect multiple (3)	9 conect multiple (3)
10 unidad cdi	10 unidad cdi
11 generador de impuls	11 generador de impuls
12 conect multiple (4)	12 conect multiple (4)
bl azul	bl azul
br marron	br marron
ge amarillo	ge amarillo
gr gris	gr gris
g verde	g verde
o naranja	o naranja
r rojo	r rojo
s negro	s negro
v violeta	v violeta
w blanco	w blanco



SERVICE

Modell 125-380 EXC 2000

Kabelstrangnummer  
vorne 503 11 075 600  
hinten 503 14 040 100  
Blinker vorne 503 11 080 100  
Blinker hinten 503 11 081 000

Land Europa

Datum, Name  
07 04 99 He

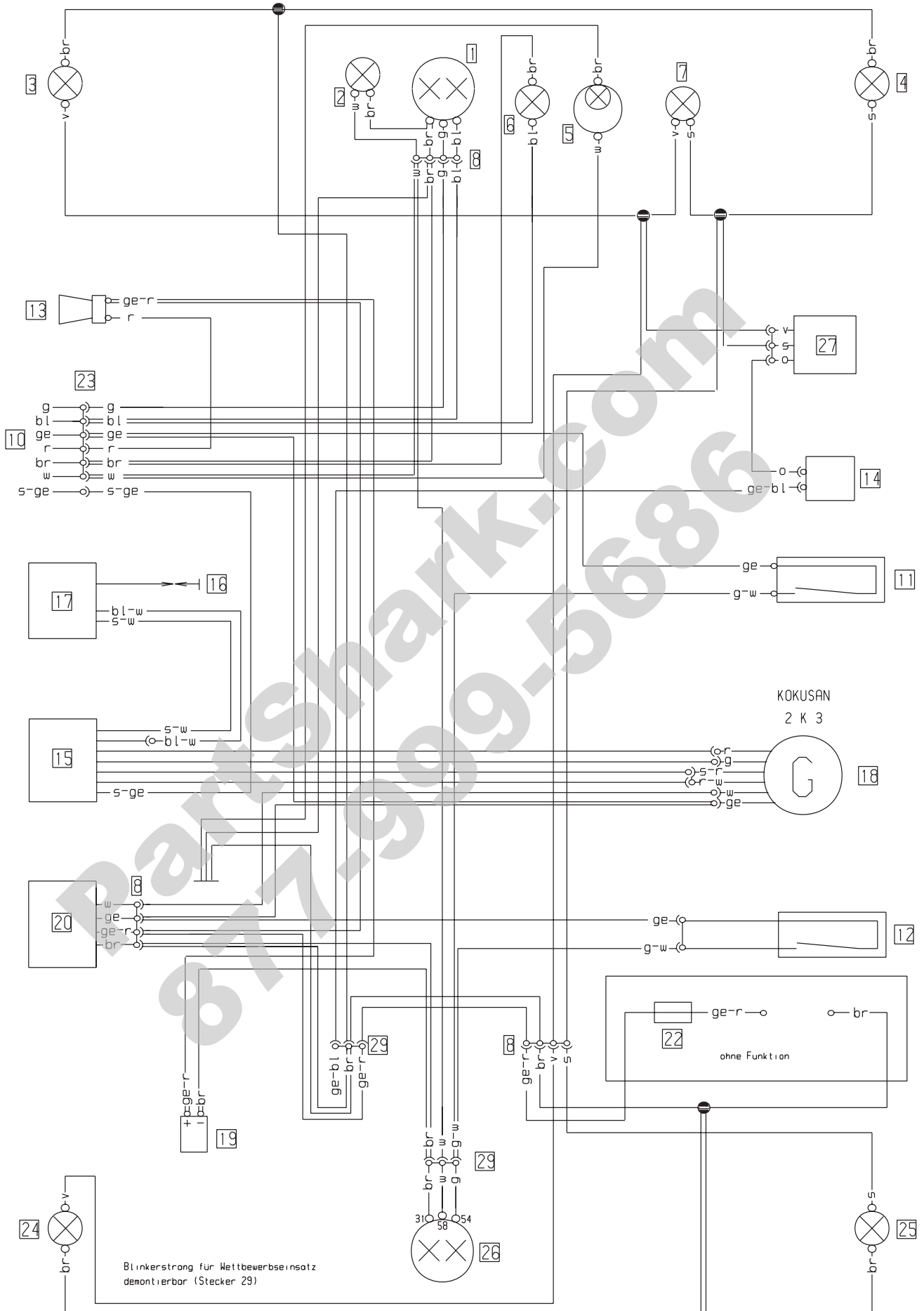

Art.-Nr. 3.206.062-E

Repair manual KTM 125 / 144 / 150 / 200

Deutsch	Englisch	Italienisch	Französisch
1 Scheinwerfer	1 headlight	1 faro	1 phare
2 Standlicht	2 parking light	2 luce di posizione	2 feu de position
3 Blinker li vo	3 turn indic left fr	3 lampegg ant sn	3 clignoteur av gauche
4 Blinker re vo	4 turn indic right fr	4 lampegg ant dx	4 clignoteur av droit
5 Tachobeleuchtung	5 speedometer light	5 luce di tachimetro	5 éclair comp vitesse
6 Fernlichtkontrolle	6 high beam indicator	6 spia abbagliante	6 témoin feu route
7 Blinkerkontrolle	7 turn indicator	7 spia lampeggiatori	7 témoin de clignoteur
8 4-pol Stecker	8 multip cont plug (4)	8 connettore a 4 poli	8 connect multiple (4)
10 zum Kombischalter	10 to combinat switch	10 multicomando	10 commodo
11 Bremslichtsch vo	11 stoplight switch f	11 int luce arresto ant	11 contact de stop av
12 Bremslichtsch hi	12 stoplight switch r	12 int luce arresto post	12 contact Harr de stop
13 Horn	13 horn	13 clacson	13 klaxon
14 Blinkgeber	14 turn indicator	14 trasmett di lampeg	14 centrale clignot
15 CDI-Einheit	15 CDI-unit	15 CDI-seatola	15 boitier CDI
16 Zündkerze	16 spark plug	16 candela	16 bougie
17 Zündspule	17 ignition coil	17 bobina d'accens	17 bobine d'allumage
18 Generator	18 generator	18 dinamo	18 generateur
19 Kondensator	19 capacitor	19 condensatore	19 condensateur
20 Spannungsregler	20 voltage regulator	20 regol di tens	20 regulateur
22 Stecksicherung 10A	22 fuse 10A	22 fusibile 10A	22 fusible 10A
23 6-pol Stecker	23 multip cont plug (6)	23 connettore a 6 poli	23 connect multiple (6)
24 Blinker li hi	24 blinker left rear	24 lampegg post sn	24 clign arr gauche
25 Blinker re hi	25 blinker right rear	25 lampegg post dx	25 clign arr droite
26 Brems-Schlußlicht	26 rear-stoplight	26 fanal post di freno	26 feu arr et de stop
27 Blinkerschalter	27 blink switch	27 int lampeggiatori	27 contact d clignoteur
29 3-pol Stecker	29 multip cont plug (3)	29 connettore a 3 poli	29 connect multiple (9)

Deutsch	Englisch	Italienisch	Französisch	Spanisch
bl blau	bl blue	bl blu	bl bleu	bl azul
br braun	br brown	br marrone	br brun	br marron
ge gelb	ge yellow	ge giallo	ge jaune	ge amarillo
gr grau	gr grey	gr grigio	gr gris	gr gris
g grün	g green	g verde	g vert	g verde
o orange	o orange	o arancione	o orange	o naranja
r rot	r red	r rosso	r rouge	r rojo
s schwarz	s black	s nero	s noir	s negro
v violett	v violet	v violetto	v violet	v violeta
w weiß	w white	w bianco	w blanc	w blanco

Blinkerschalter

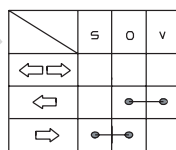

Kontaktbelegung -  
Lichtschalter (Typ CEV 9610)

	g	bl	ge	w	ge/s	r	br
LICHT $\odot$							
Ablendl	$\bullet$	—	$\bullet$	$\bullet$			
Fernlicht		$\bullet$	—	$\bullet$			
HUPE						$\bullet$	$\bullet$
ZÜNDUNG AUS					$\bullet$	—	$\bullet$
	5	2	1	3	6	4	

Spanisch
1 faro
2 luz de posicion
3 interm izquierdo delantero
4 intermitente derecho delantero
5 luz tacometro
6 lampara aviso luces largas
7 lampara aviso intermitentes
8 conector multiple (4)
10 interruptor combinado
11 interr luz de freno del
12 interr luz de fren tras
13 claxon
14 conjunto del intermitente
15 unidad cdi
16 bujia
17 bobina de encendido
18 generador
19 condensador
20 regulador de tension
22 fusible principal 10A
23 conector multiple (6)
24 intermitente izquierdo trasero
25 intermitente derecho trasero
26 luz de freno trasero
27 interuptor clignoteur
29 conector multiple (3)



SERVICE

Modell: 125 EXE 2000/2001  
125 Super Moto 2000/2001

Kabelstrangnummer:  
vorne:512.11.075.000  
hinten:503.14.040.100

Land:  
Europa

Datum, Name:  
22.11.99 Hasl.

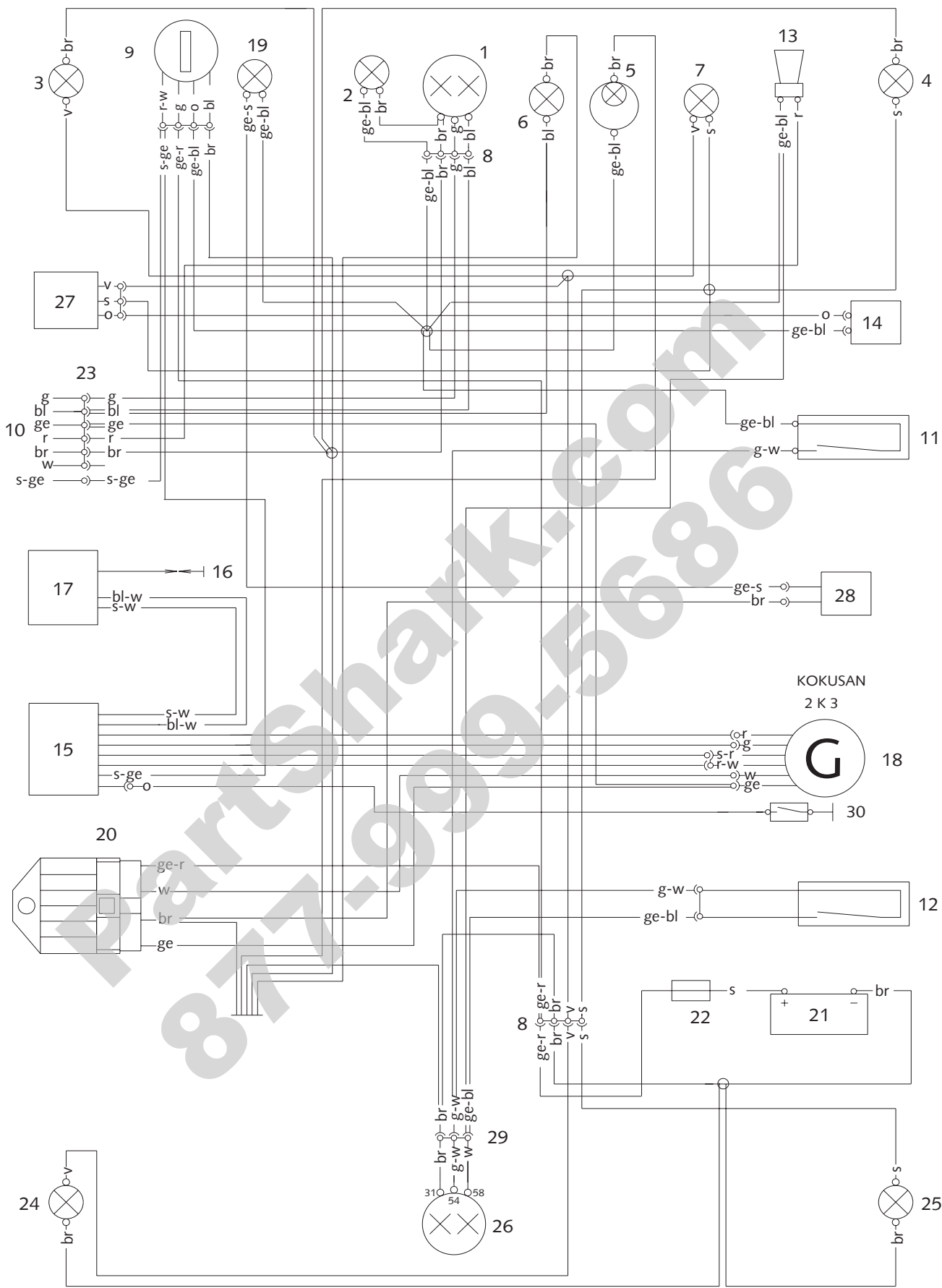

Art.-Nr. 3.206.062-E

Repair manual KTM 125 / 144 / 150 / 200

Deutsch	Englisch	Italienisch	Französisch
1 Scheinwerfer	1 headlight	1 faro	1 phare
2 Standlicht	2 parking light	2 luce di posizione	2 feu de position
3 Blinker li vo	3 turn indic.left fr.	3 lampegg.ant.sn.	3 clignoteur av gauche
4 Blinker re vo	4 turn indic.right fr.	4 lampegg.ant.dx.	4 clignoteur av.droit
5 Tachobeleuchtung	5 speedometer light	5 luce di tachimetro	5 éclair.comp.vitesse
6 Fernlichtkontrolle	6 high beam indicator	6 spia abbagliante	6 témoin feu route
7 Blinkerkontrolle	7 turn indicator	7 spia lampeggiatori	7 témoin de clignoteur
8 4-pol.Stecker	8 multip.cont.plug (4)	8 connettore a 4 poli	8 connect.multiple (4)
9 Zündschloss	9 ignition lock	9 accensione	9 contact.d'allum.
10 zum Kombischalter	10 to combinat. switch	10 multicomando	10 commodo
11 Bremslichtsch. vo	11 stoplight switch f.	11 int.luce arresto ant	11 contact de stop av.
12 Bremslichtsch. hi	12 stoplight switch r.	12 int.luce arresto post	12 contact Harr.de stop
13 Horn	13 horn	13 clacson	13 klaxon
14 Blinkgeber	14 turn indicator	14 trasmett. di lampeg.	14 centrale clignot.
15 CDI-Einheit	15 CDI-unit	15 CDI-seatola	15 boitier CDI
16 Zündkerze	16 spark plug	16 candela	16 bougie
17 Zündspule	17 ignition coil	17 bobina d'accens.	17 bobine d'allumage
18 Generator	18 generator	18 dinamo	18 generateur
19 Ölkontrolleuchte	19 oil level tell tale	19 contr.d.liv.d'olio	19 contr.de niv d huile
20 Spannungsregler	20 voltage regulator	20 regol. di tens.	20 regulateur
21 Batterie 3Ah	21 battery 3Ah	21 batteria 3Ah	21 batterie 3Ah
22 Stecksicherung 10A	22 fuse 10A	22 fusibile 10A	22 fusible 10A
23 6-pol.Stecker	23 multip.cont.plug (6)	23 connettore a 6 poli	23 connect.multiple (6)
24 Blinker li hi	24 blinker left rear	24 lampegg.post.sn	24 clign.arr.gauche
25 Blinker re hi	25 blinker right rear	25 lampegg.post.dx.	25 clign.arr.droite
26 Brems-Schlusslicht	26 rear-stoplight	26 fanal.post.di freno	26 feu arr.et de stop
27 Blinkerschalter	27 blink switch	27 int. lampeggiatori	27 contact.d.clignoteur
28 Ölstandgeber	28 oil level sensor	28 liv.d'olio transmet.	28 niv.d'huile transmet
29 3-pol. Stecker	29 multip.cont.plug (3)	29 connettore a 3 poli	29 connect.multiple (3)
30 kontaktstift 3.Gang	30 gear switch 3.gear	30 secondo marcia	30 cont.d.boite d.vites

Deutsch	Englisch	Italienisch	Französisch	Spanisch
bl blau	bl blue	bl blu	bl bleu	bl azul
br braun	br brown	br marrone	br brun	br marron
ge gelb	ge yellow	ge giallo	ge jaune	ge amarillo
gr grau	gr grey	gr grigio	gr gris	gr gris
g grün	g green	g verde	g vert	g verde
o orange	o orange	o arancione	o orange	o naranja
r rot	r red	r rosso	r rouge	r rojo
s schwarz	s black	s nero	s noir	s negro
v violett	v violet	v violetto	v violet	v violeta
w weiss	w white	w bianco	w blanc	w blanco

Zündschloss

ZADI (503.11.065.000)

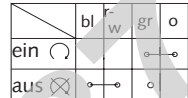

Blinkerschalter

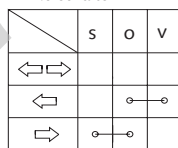

Kontaktbelegung - Lichtschalter (Typ CEV 9610)

	g	bl	ge	w	s/ge	r	br
LICHT							
Abblendl.							
Fernlicht							
HUPE							
ZÜNDUNG AUS							
	5	2	1	3	6	4	

Spanisch
1 faro
2 luz de posicion
3 interm. izquierdo delantero
4 intermitente derecho delantero
5 luz tacometro
6 lampara aviso luces largas
7 lampara aviso intermitentes
8 conector multiple (4)
9 llave de contacto
10 interruptor combinado
11 interr. luz de freno del.
12 interr. luz. de fren tras.
13 claxon
14 conjunto del intermitente
15 unidad cdi
16 bujia
17 bobina de encendido
18 generador
19 contr.del nivel del aceite
20 regulador de tension
21 bateria 12V 3Ah
22 fusible principal 10A
23 conector multiple (6)
24 intermitente izquierdo trasero
25 intermitente derecho trasero
26 luz de freno trasero
27 interuptor clignoteur
28 sensor.del nivel del aceite
29 conector multiple (3)
30 interruptor de cambio (3)





SERVICE

Modell  
125-200 EXC 2001/2002

Kabelstrangnummer  
vorne 503 11 075 700  
hinten 503 14 040 100  
Blinkerstrang vorne 590 11 080 000  
Blinkerstrang hinten 590 11 081 000

Land  
EU

Datum, Name  
04 05 00 KE

Dateiname  
EXC2001

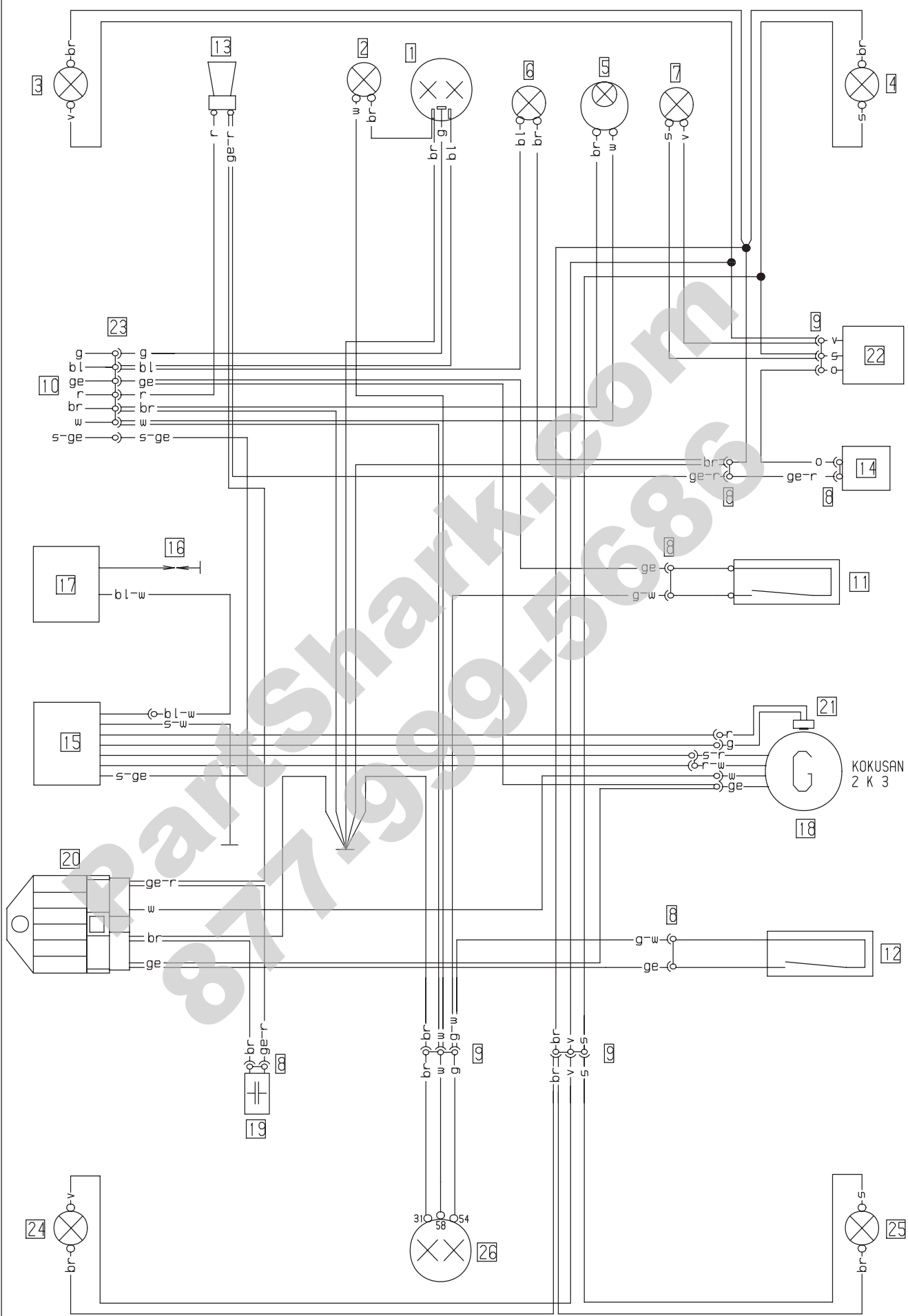

Art.-Nr. 3.206.062-E

Repair manual KTM 125 / 144 / 150 / 200

# KTM 125-200 EXC 2001/2002

Deutsch	Englisch	Italienisch	Französisch
1 Scheinwerfer	1 headlight	1 faro	1 phare
2 Standlicht	2 position light	2 luce di posizione	2 feu de position
3 Blinker li vo	3 turn indic left fr	3 lampegg ant sn	3 clignoteur av gauche
4 Blinker re vo	4 turn indic right fr	4 lampegg ant dx	4 clignoteur av droit
5 Tachobeleuchtung	5 speedometer light	5 luce di tachimetro	5 éclair comp vitesse
6 Fernlichtkontrolle	6 high beam indicator	6 spia abbagliante	6 témoin feu route
7 Blinkerkontrolle	7 turn indicator	7 spia lampeggiatori	7 témoin de clignoteur
8 2-pol Stecker	8 multip cont plug (2)	8 connettore a 2 poli	8 connect multiple (2)
9 3-pol Stecker	9 multip cont plug (3)	9 connettore a 3 poli	9 connect multiple (3)
10 zum Kombischalter	10 to combinat switch	10 multicomando	10 commodo
11 Bremslichtsch vo	11 stoplight switch f	11 int luce arresto ant	11 contact de stop av
12 Bremslichtsch hi	12 stoplight switch r	12 int luce arresto post	12 contact Harr de stop
13 Horn	13 horn	13 clacson	13 klaxon
14 Blinkgeber	14 turn indicator	14 trasmett di lampeg	14 centrale clignot
15 CDI	15 CDI	15 CDI	15 CDI
16 Zündkerze	16 spark plug	16 candela	16 bougie
17 Zündspule	17 ignition coil	17 bobina d'accens	17 bobine d'allumage
18 Generator	18 generator	18 dinamo	18 generateur
19 Kondensator	19 capacitor	19 condensatore	19 condensateur
20 Spannungsregler	20 voltage regulator	20 regol di tens	20 regulateur
21 Impulsgeber	21 pulser coil	21 trasmett d'impulsi	21 generateur d'impuls
22 Blinkerschalter	22 blink switch	22 int lampeggiatori	22 contact d clignateur
23 6-pol Stecker	23 multip cont plug (6)	23 connettore a 6 poli	23 connect multiple (6)
24 Blinker li hi	24 blinker left rear	24 lampegg post sn	24 clign arr gauche
25 Blinker re hi	25 blinker right rear	25 lampegg post dx	25 clign arr droite
26 Brems-Schlußlicht	26 rear-stoplight	26 fanal post di freno	26 feu arr et de stop

Deutsch	Englisch	Italienisch	Französisch	Spanisch
bl blau	bl blue	bl blu	bl bleu	bl azul
br braun	br brown	br marrone	br brun	br marron
ge gelb	ge yellow	ge giallo	ge jaune	ge amarillo
gr grau	gr grey	gr grigio	gr gris	gr gris
g grün	g green	g verde	g vert	g verde
o orange	o orange	o arancione	o orange	o naranja
r rot	r red	r rosso	r rouge	r rojo
s schwarz	s black	s nero	s noir	s negro
v violett	v violet	v violetto	v violet	v violeta
w weiß	w white	w bianco	w blanc	w blanco

Spanisch
1 faro
2 luz de posicion
3 interm izquierdo delantero
4 intermitente derecho delantero
5 luz tacometro
6 lampara aviso luces largas
7 lampara aviso intermitentes
8 conector multiple (2)
9 conector multiple (3)
10 interruptor combinado
11 interr luz de freno del
12 interr luz de fren tras
13 claxon
14 conjunto del intermintente
15 CDI
16 bujia
17 bobina de encendido
18 generador
19 condensador
20 regulador de tension
21 generador de impulsos
22 interruptor clignoteur
23 conector multiple (6)
24 intermitente izquierdo trasero
25 intermitente derecho trasero
26 luz de freno trasero

Kontaktbelegung -  
Lichtschalter (Typ CEV 9610)

	g	bl	ge	w	ge /s	r	br
Lights							
LO beam	●	●	●	●			
Hi beam		●	●	●			
Horn						●	●
Engine off					●	●	
	5	2	1	3	6	4	

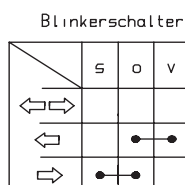

**KTM** SPORTMOTORCYCLES

Model l I **KTM 125/200 EXC 2001/2002**

Kabelstrangnummer vorne 503 11 075 000 hinten 503 11 076 000

Land **USA**

Datum, Name 22.06.98 KE

Zeichnungsnr 1-3XCUSA

Determino 1-3XCUS1  
Änderung 100400

Kabelstrangbez vo 125 EXC USA '98 hi 125-250 EXC '98

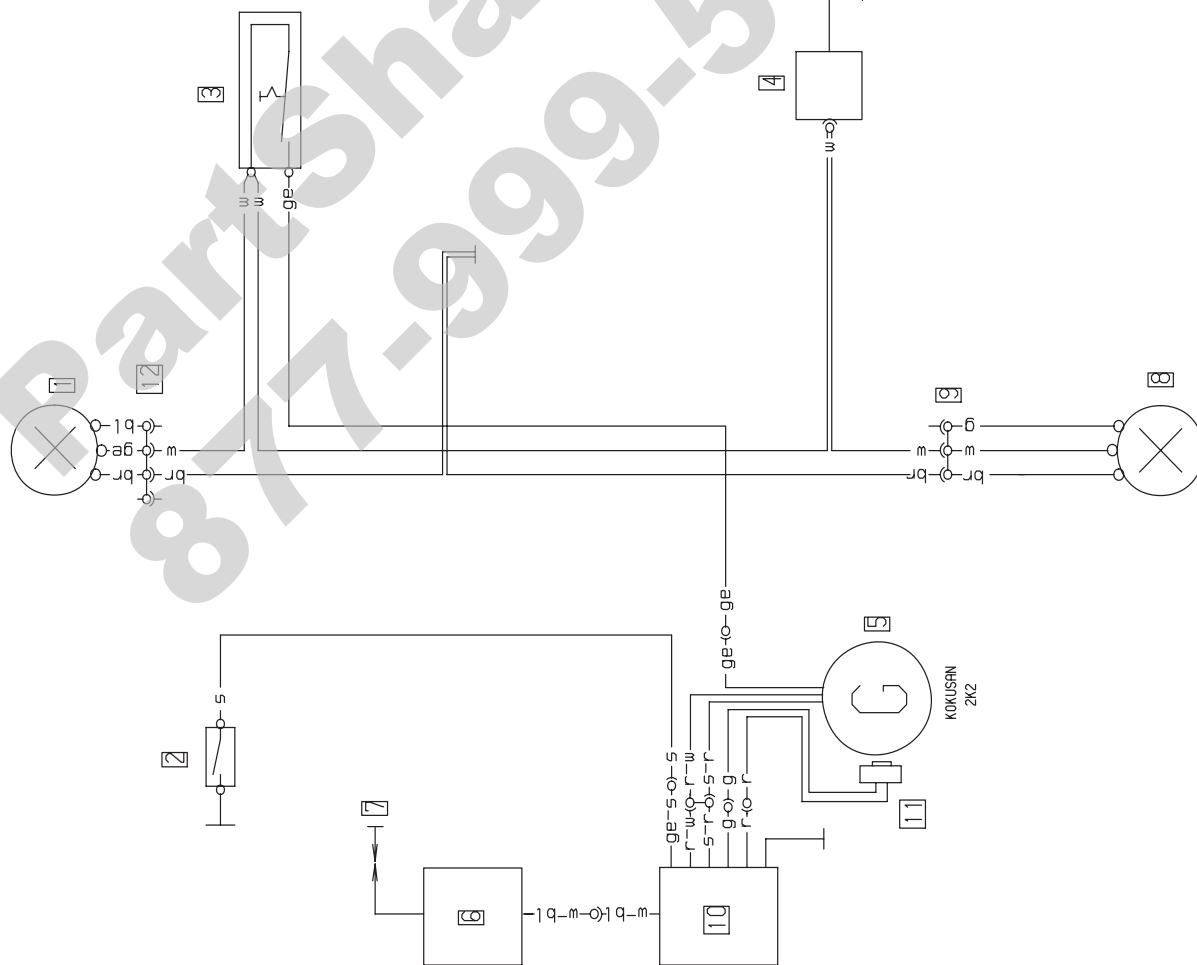

Deutsch	Englisch	Italienisch	Französisch
1 Scheinwerfer	1 headlight	1 fano	1 phare
2 Kurzschlußtaster	2 short-circuit button	2 interr cortocircuito	2 bouton d'arret
3 Lichtschalter	3 light switch	3 interr della luce	3 interr d'eclairage
4 Spannungsbegrenzer	4 voltage limiter	4 regol di tens	4 regulateur
5 Generator	5 generator	5 dinamo	5 generateur
6 Zündspule	6 ignition coil	6 bobina d'accens	6 bobine d'allumage
7 Zündkerze	7 spark plug	7 candela	7 bougie
8 Schlußlicht	8 rear light	8 fanale posteriore	8 feu arriere
9 3-pol Stecker	9 multip cont plug (3)	9 connettore a 3 poli	9 connect multiple (3)
10 CDI-Einheit	10 CDI-unit	10 CDI-seatola	10 CDI-unite
11 Impulsgeber	11 pulser coil	11 distributore	11 generateur d'impuls
12 4-pol Stecker	12 multip cont plug (4)	12 connettore a 4 poli	12 connect multiple (4)
bl blau	bl blue	bl blu	bl bleu
br braun	br brown	br marrone	br brun
ge gelb	ge yellow	ge giallo	ge jaune
gr grau	gr grey	gr grigio	gr gris
g grün	g green	g verde	g vert
o orange	o orange	o arancione	o orange
r rot	r red	r rosso	r rouge
s schwarz	s black	s nero	s noir
v violett	v violet	v violetto	v violet
w weiß	w white	w bianco	w blanc

Spanisch
1 fano
2 interruptor a masa
3 interruptor d'luz
4 regulador de tension
5 generador
6 bobina de encendido
7 bujia
8 luz de trasera
9 conect multiple (3)
10 unidad cdi
11 generador de impuls
12 conect multiple (4)
bl azul
br marron
ge amarillo
gr gris
g verde
o naranja
r rojo
s negro
v violeta
w blanco



SERVICE

Modell  
125-200 EXC 2003

Kabelstrangnummer: vorne: 503.11.075.800  
hinten: 503.14.040.100  
Blinkerstrang vorne: 590.11.080.000  
Blinkerstrang hinten: 590.11.081.000

Land:  
EU/AUS

Datum, Name:  
18.03.02 KE

Dateiname:  
EXC2003

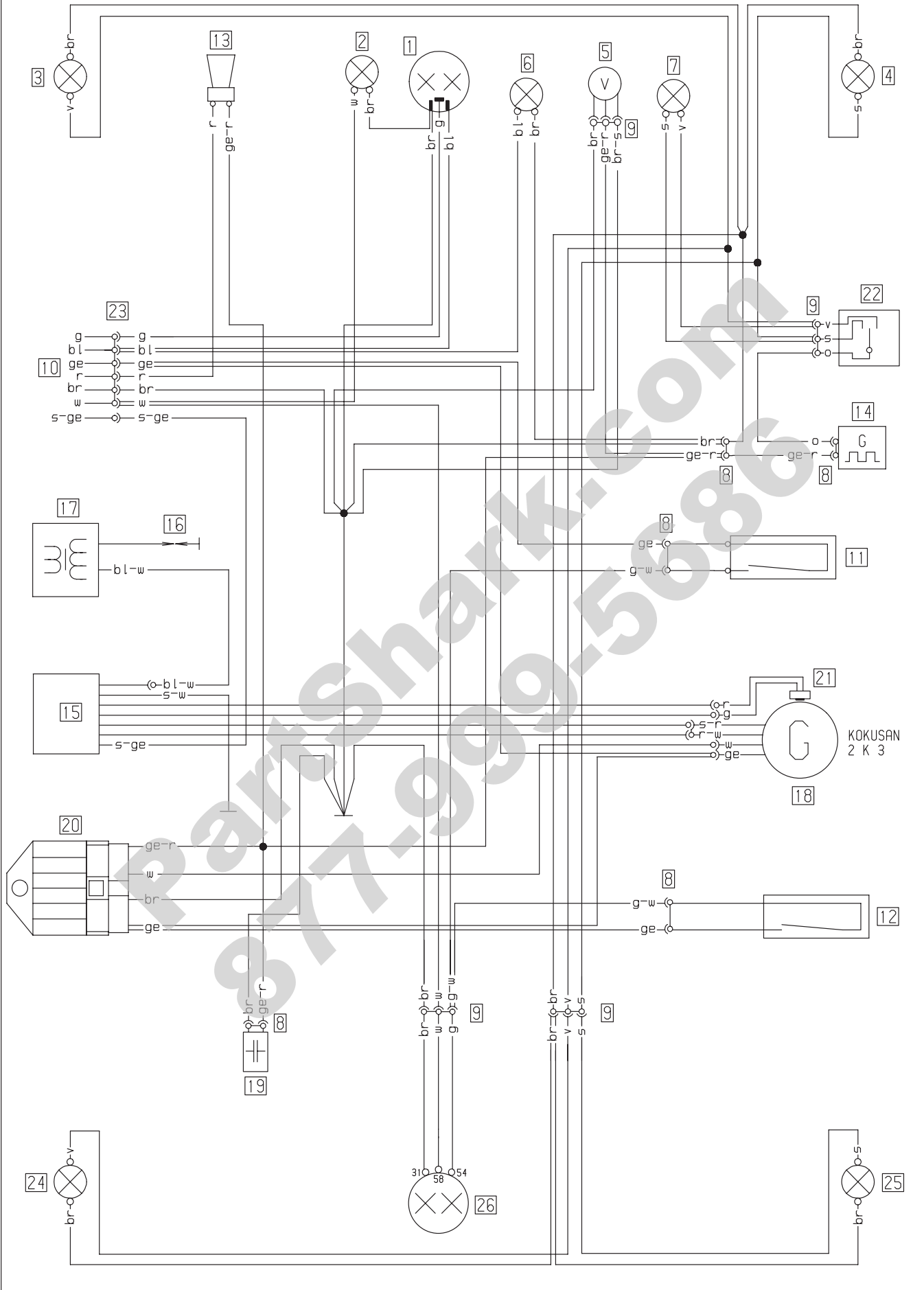

# KTM 125-200 EXC 2003





Deutsch	Englisch	Italienisch	Französisch
1 Scheinwerfer	1 headlight	1 faro	1 phare
2 Standlicht	2 position light	2 luce di posizione	2 feu de position
3 Blinker li vo	3 turn indic. left fr.	3 lampegg. ant. sn.	3 clignoteur av. gauche
4 Blinker re vo	4 turn indic. right fr.	4 lampegg. ant. dx.	4 clignoteur av. droit
5 Tacho	5 speedometer	5 tachimetro	5 compteur
6 Fernlichtkontrolle	6 high beam indicator	6 spia abbagliante	6 témoin feu route
7 Blinkerkontrolle	7 turn indicator	7 spia lampeggiatori	7 témoin de clignoteur
8 2-pol. Stecker	8 multip. cont. plug (2)	8 connettore a 2 poli	8 connect. multiple (2)
9 3-pol. Stecker	9 multip. cont. plug (3)	9 connettore a 3 poli	9 connect. multiple (3)
10 zum Kombischalter	10 to combinat. switch	10 multicomando	10 commodo
11 Bremslichtsch. vo	11 stoplight switch f.	11 int. luce arresto ant.	11 contact de stop av.
12 Bremslichtsch. hi	12 stoplight switch r.	12 int. luce arresto post.	12 contact Harr. de stop
13 Horn	13 horn	13 clacson	13 klaxon
14 Blinkgeber	14 turn indicator	14 trasmett. di lampeg.	14 centrale clignot.
15 CDI	15 CDI	15 CDI	15 CDI
16 Zündkerze	16 spark plug	16 candela	16 bougie
17 Zündspule	17 ignition coil	17 bobina d'accens.	17 bobine d'allumage
18 Generator	18 generator	18 dinamo	18 generateur
19 Kondensator	19 capacitor	19 condensatore	19 condensateur
20 Spannungsregler	20 voltage regulator	20 regol. di tens.	20 regulateur
21 Impulsgeber	21 pulser coil	21 trasmett. d'impulsi	21 generateur d'impuls.
22 Blinkerschalter	22 blink switch	22 int. lampeggiatori	22 contact d.clignateur
23 6-pol. Stecker	23 multip. cont. plug (6)	23 connettore a 6 poli	23 connect. multiple (6)
24 Blinker li hi	24 blinker left rear	24 lampegg. post. sn.	24 clign. arr. gauche
25 Blinker re hi	25 blinker right rear	25 lampegg. post. dx.	25 clign. arr. droite
26 Brems-Schlußlicht	26 rear-stoplight	26 fanal. post. di freno	26 feu arr. et de stop

Art.-Nr. 3.206.062-E

Deutsch	Englisch	Italienisch	Französisch	Spanisch
bl blau	bl blue	bl blu	bl bleu	bl azul
br braun	br brown	br marrone	br brun	br marron
ge gelb	ge yellow	ge giallo	ge jaune	ge amarillo
gr grau	gr grey	gr grigio	gr gris	gr gris
g grün	g green	g verde	g vert	g verde
o orange	o orange	o arancione	o orange	o naranja
r rot	r red	r rosso	r rouge	r rojo
s schwarz	s black	s nero	s noir	s negro
v violett	v violet	v violetto	v violet	v violeta
w weiß	w white	w bianco	w blanc	w blanco

Spanisch
1 faro
2 luz de posicion
3 interm. izquierdo delantero
4 intermitente derecho delantero
5 tacometro
6 lampara aviso luces largas
7 lampara aviso intermitentes
8 conector multiple (2)
9 conector multiple (3)
10 interruptor combinado
11 interr. luz de freno del.
12 interr. luz. de fren tras.
13 claxon
14 conjunto del intermintente
15 CDI
16 bujia
17 bobina de encendido
18 generador
19 condensador
20 regulador de tension
21 generado de impulsos
22 interuptor clignoteur
23 conector multiple (6)
24 intermitente izquierdo trasero
25 intermitente derecho trasero
26 luz de freno trasero

Kontaktbelegung - Lichtschalter

	g	bl	ge	w	s/ge	r	br
Lights ●							
LO beam 	●	●	●				
Hi beam 		●	●	●			
Horn 						●	●
Engine off 					●	●	
	5	2	1	3	6	4	

Blinkerschalter

	s	o	v
←			
→		●	●
↔		●	●

Repair manual KTM 125 / 144 / 150 / 200

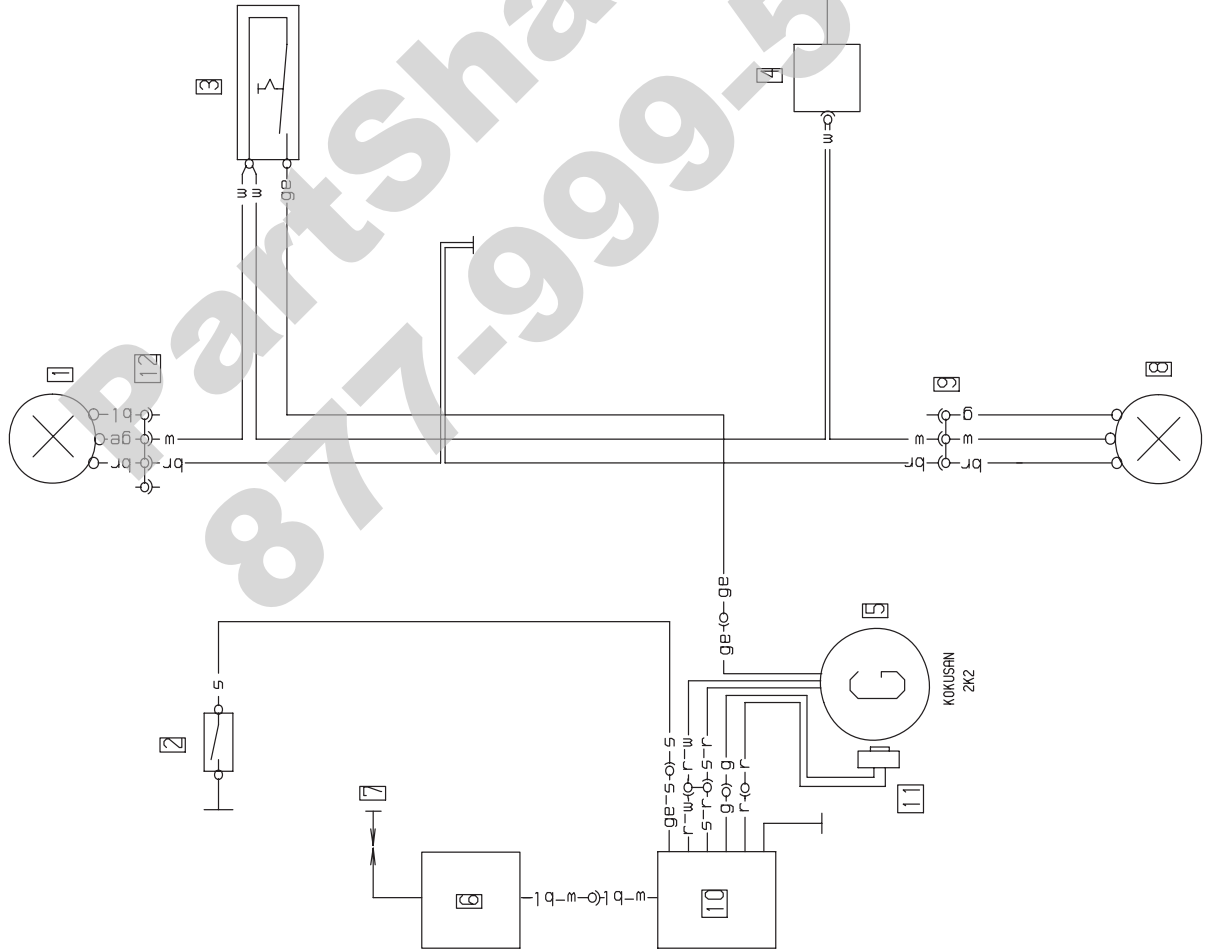

Deutsch	Englisch	Italianisch	Französisch
1 Scheinwerfer	1 headlight	1 fero	1 phare
2 Kurzschlußtafter	2 short-circuit button	2 interr cortocircuito	2 bouton d'arret
3 Lichtschalter	3 light switch	3 interr della luce	3 interr d'clairage
4 Spannungsbegrenzer	4 voltage limiter	4 regol di tens	4 regulateur
5 Generator	5 generator	5 dinamo	5 generateur
6 Zündspule	6 ignition coil	6 bobina d'accens	6 bobine d'allumage
7 Zündkerze	7 spark plug	7 candela	7 bougie
8 Schlußlicht	8 rearlight	8 fanale posteriore	8 feu arriere
9 3-pol Stecker	9 multip cont plug (3)	9 connettore a 3 poli	9 connect multiple (3)
10 CDI-Einheit	10 CDI-unit	10 CDI-seatola	10 CDI-unite
11 Impulsgeber	11 pulser coil	11 distributore	11 generateur d'impuls
12 4-pol Stecker	12 multip cont plug (4)	12 connettore a 4 poli	12 connect multiple (4)
bl blau	bl blue	bl blu	bl bleu
br braun	br brown	br marrone	br brun
ge gelb	ge yellow	ge giallo	ge jaune
gr grau	gr grey	gr grigio	gr gris
g grün	g green	g verde	g vert
o orange	o orange	o arancione	o orange
r rot	r red	r rosso	r rouge
s schwarz	s black	s nero	s noir
v violett	v violet	v violetto	v violet
w weiß	w white	w bianco	w blanc

Spanisch
1 fero
2 interruptor a masa
3 interruptor d' luz
4 regulador de tension
5 generador
6 bobina de encendido
7 bujia
8 luz de trasera
9 conect multiple (3)
10 unidad cdi
11 generador de impuls
12 conect multiple (4)
bl azul
br marron
ge amarillo
gr gris
g verde
o naranja
r rojo
s negro
v violeta
w blanco



125/200 EXC 2004

wiring diagramm

main harness

503.11.075.850

22.05.2003

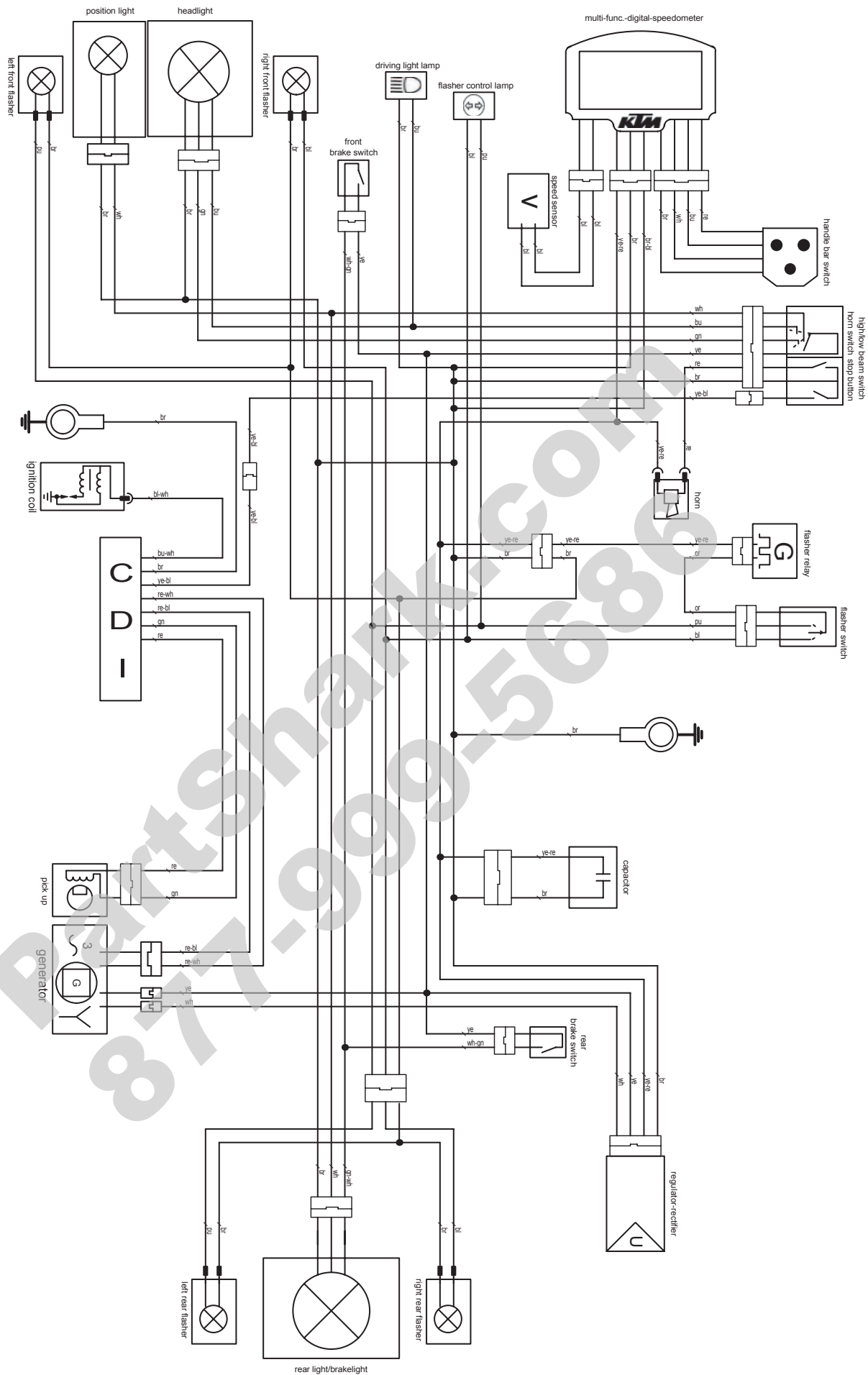



125/200 EXC-USA 2004

wiring diagram

main harness

523.1.075.000

22.05.2003

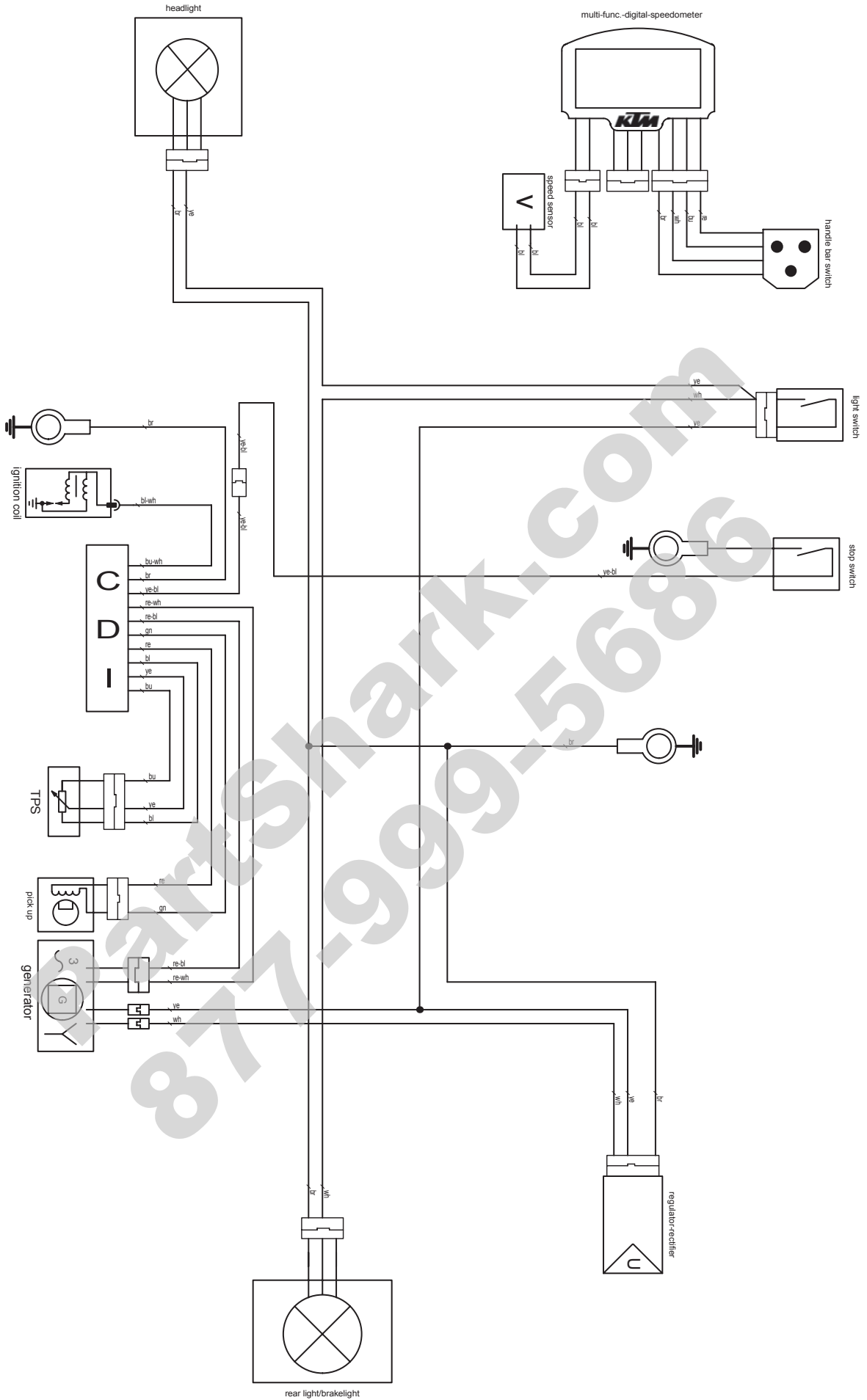





125/200 SX

19.05.2003

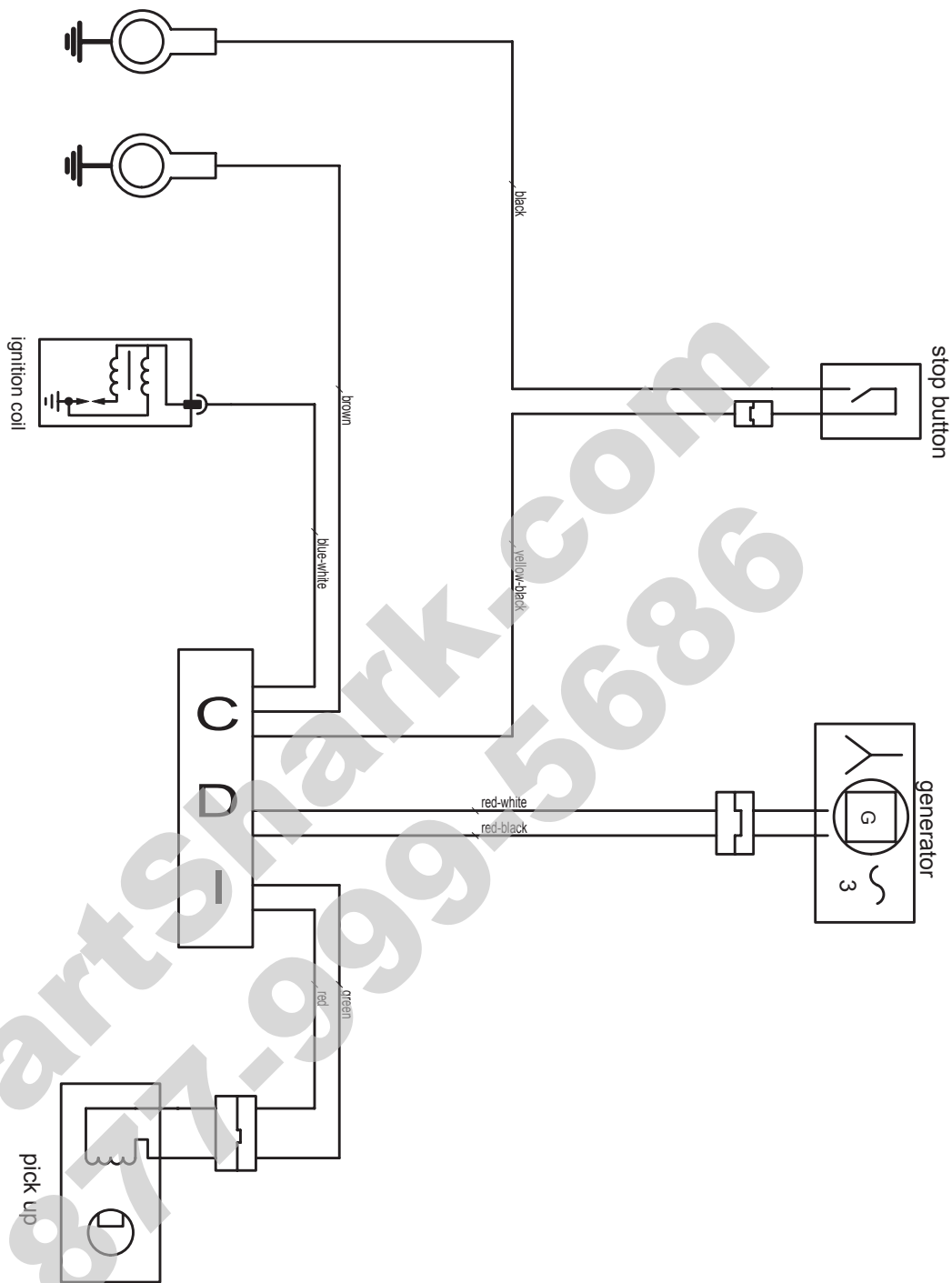



EXC 125-200 2005

wiring diagram

main harness

548.11.075.250

20.02.2004

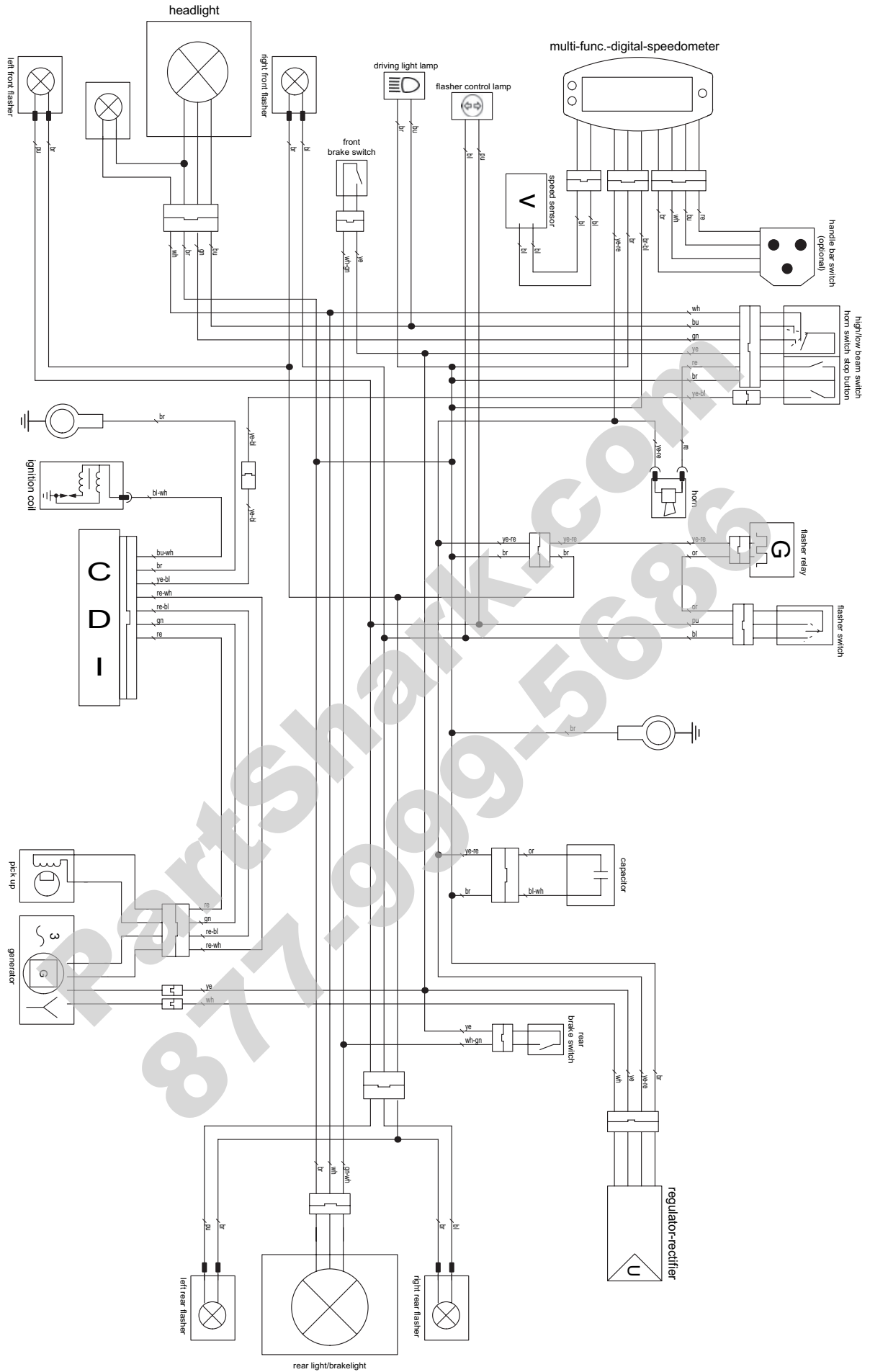



EXC-USA 200 05

wiring diagram

main harness

548.11.075.000

20.02.2004

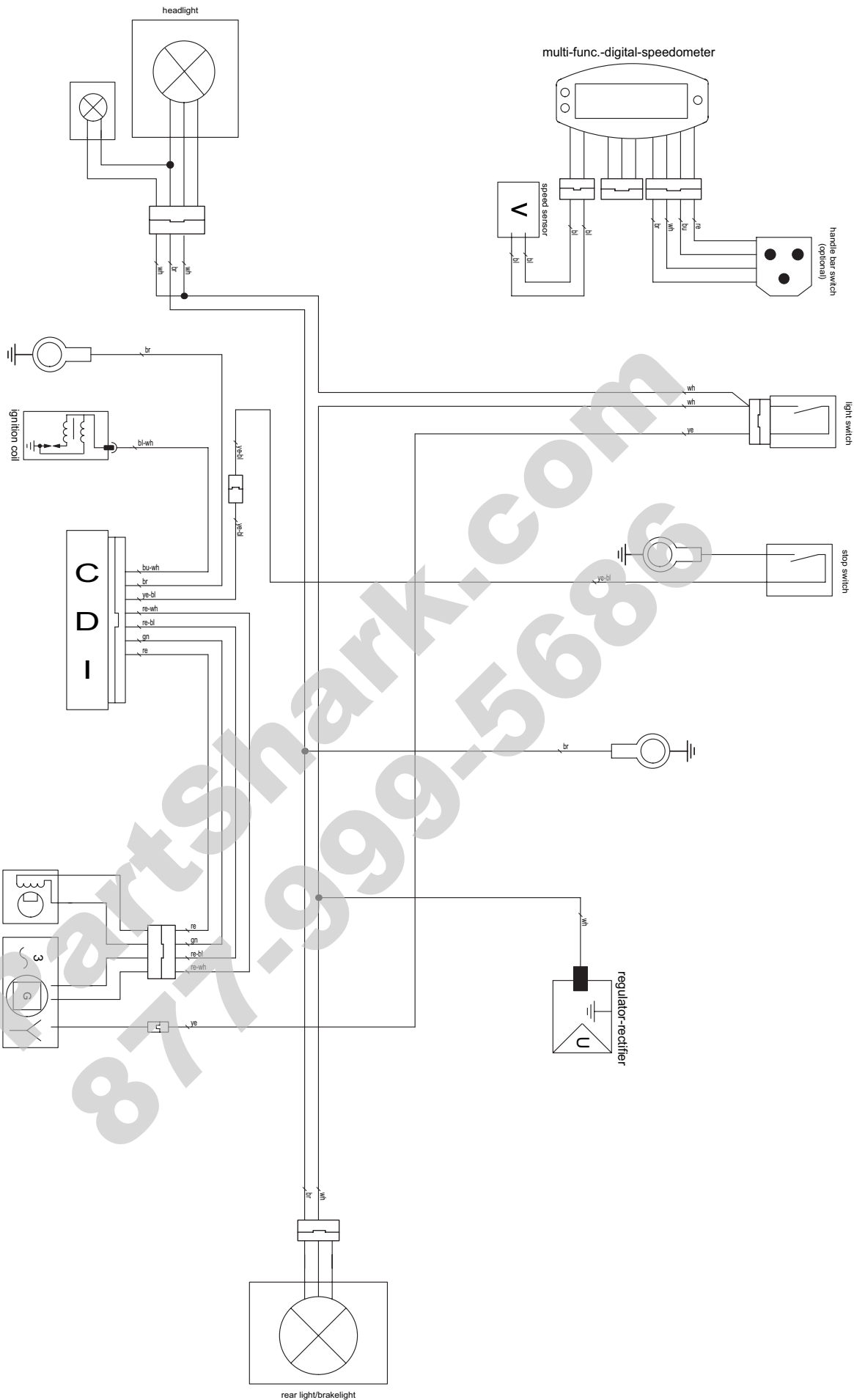



SX/SXS 125 2005/2006 XC 200 2006

548.39.032.000

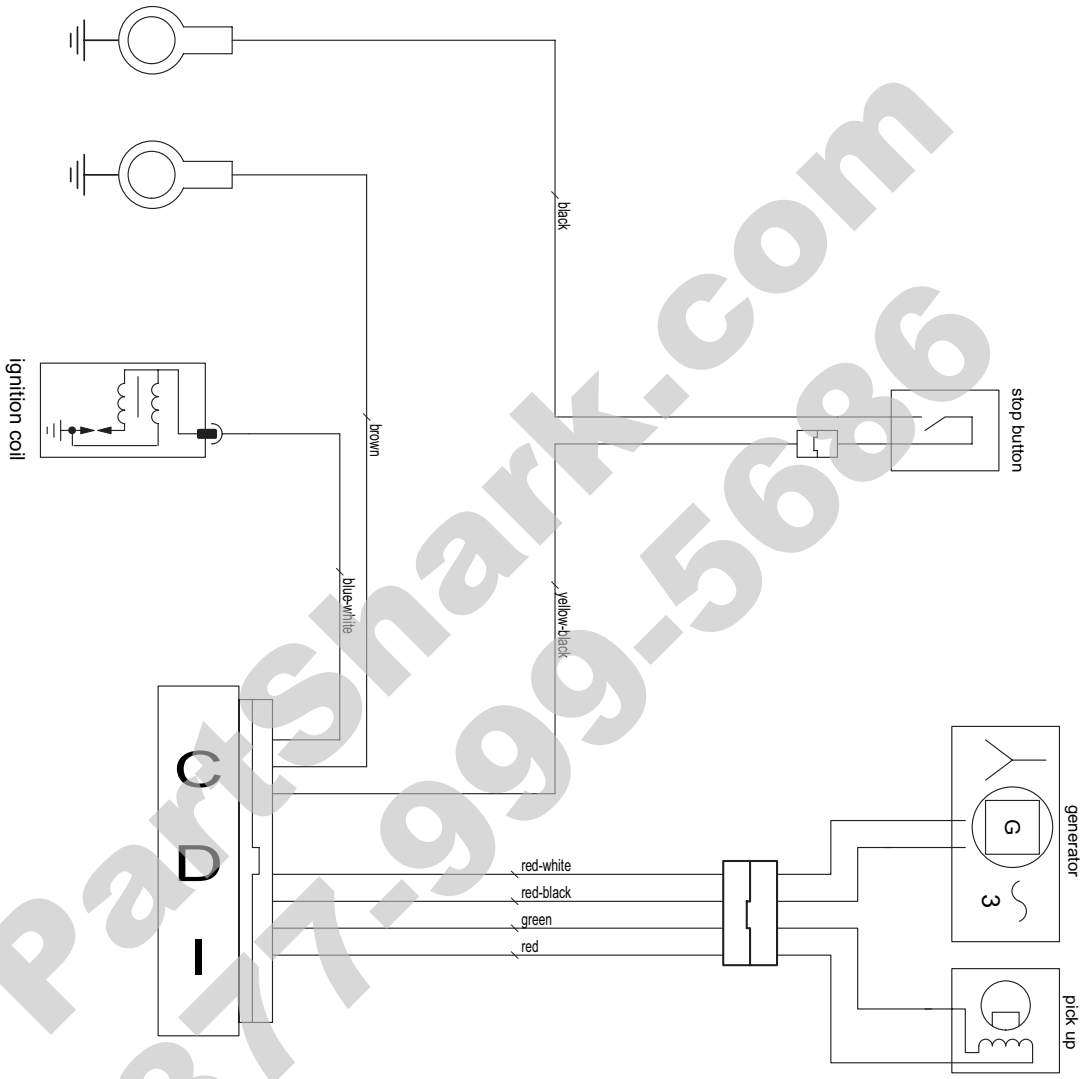

Partshark.com  
877-999-5686



EXC 125-200 2006

wiring diagram

main harness 548.11.075.350

20.02.2005

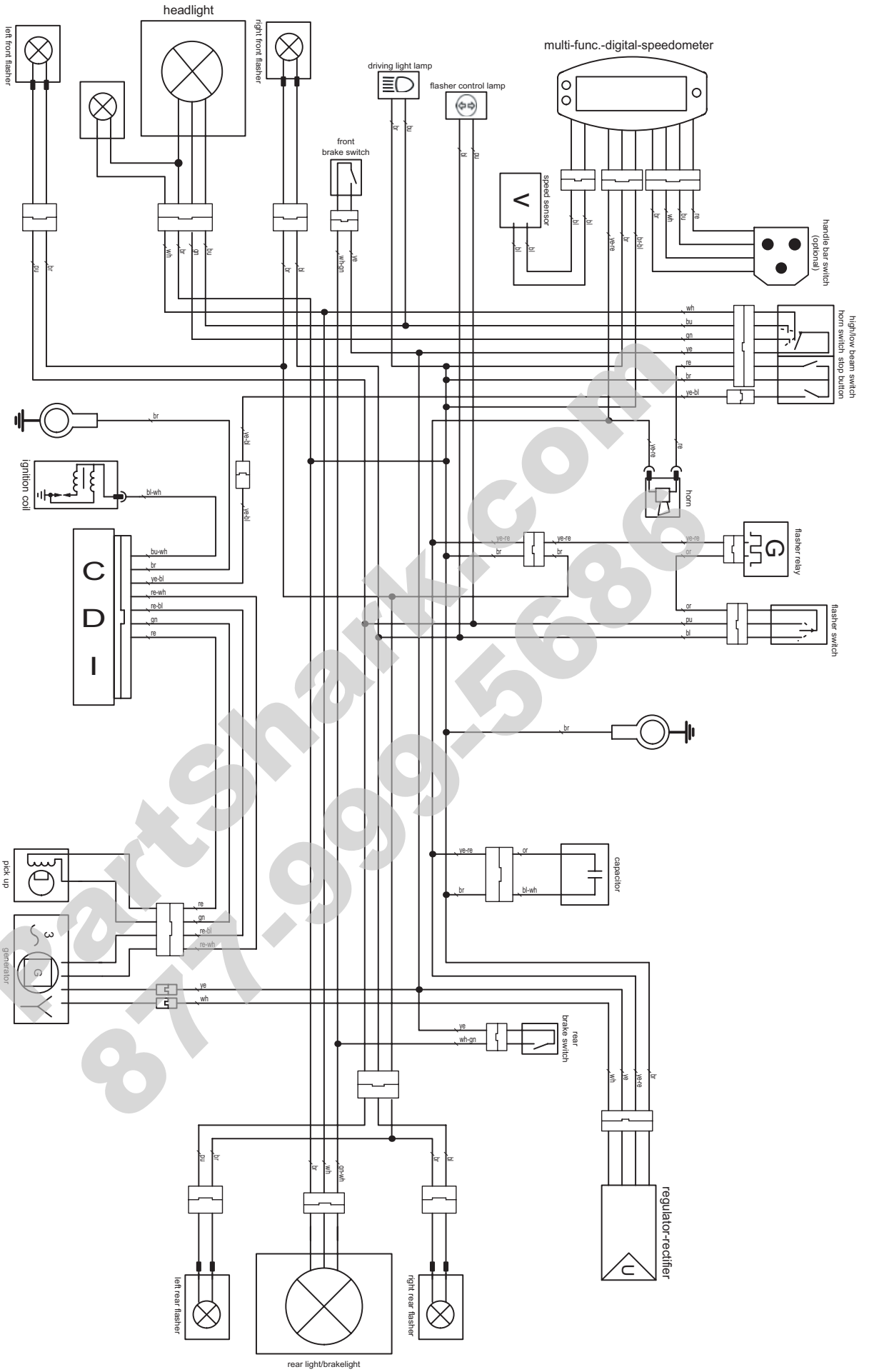



XC-W 200 2006

wiring diagram

main harness

548.11.075.000

20.02.2005

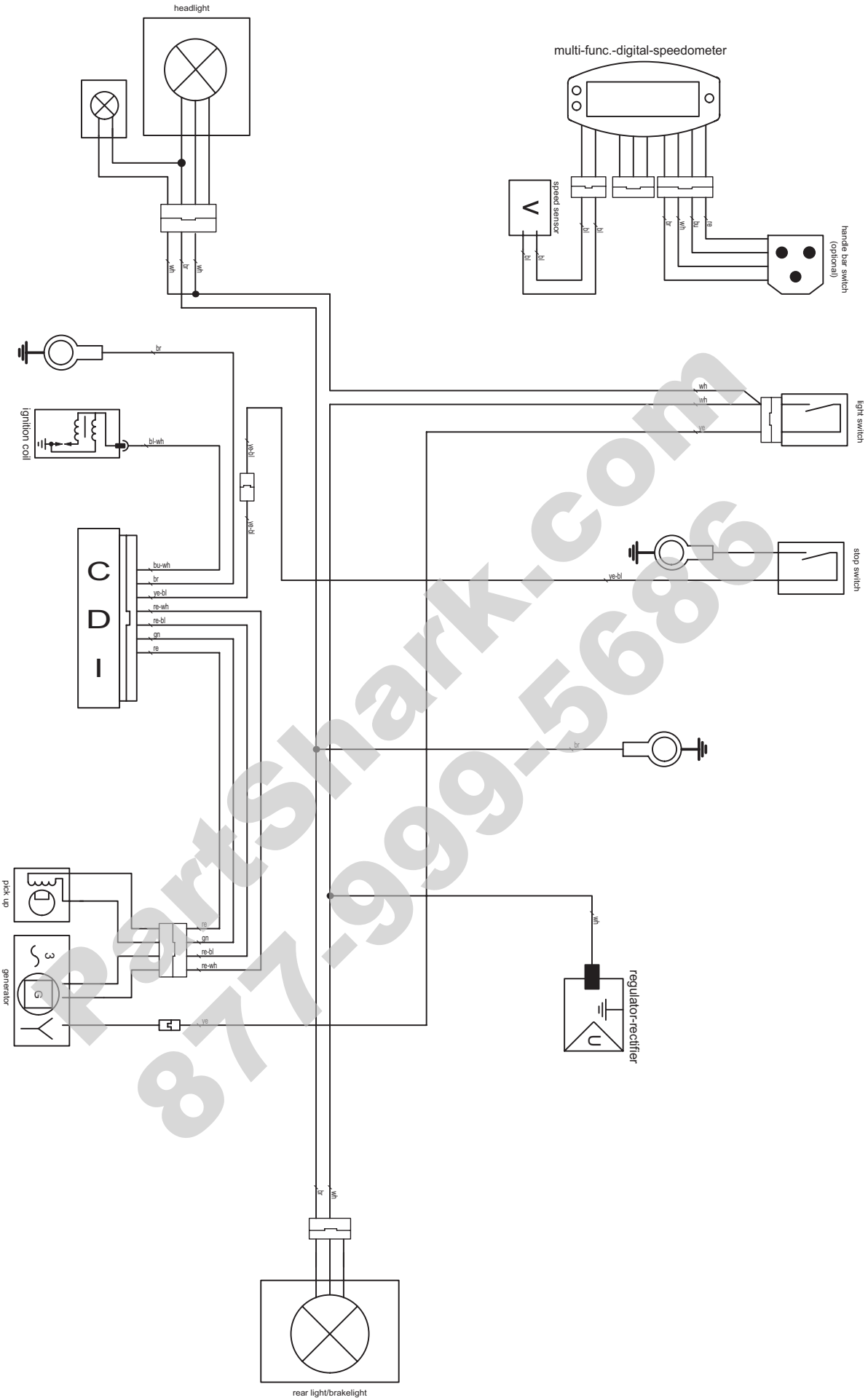



EXC 125/200 2007

wiring diagramm

main harness 548.11.075.350

10.04.2006

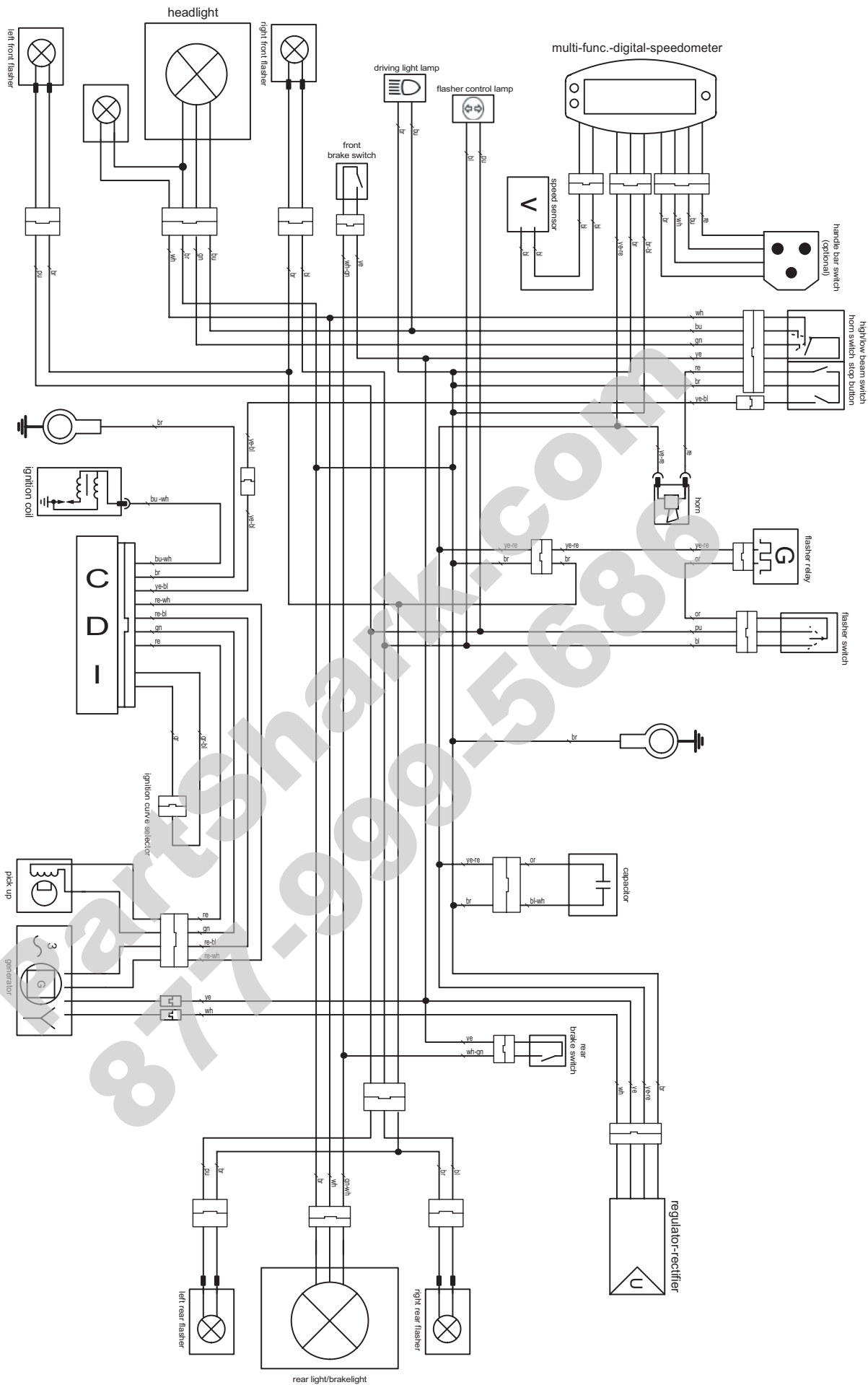



SX 125/144 2007 / SXS 125 2007  
200 XC 2007

548.39.032.300

10.04.2006

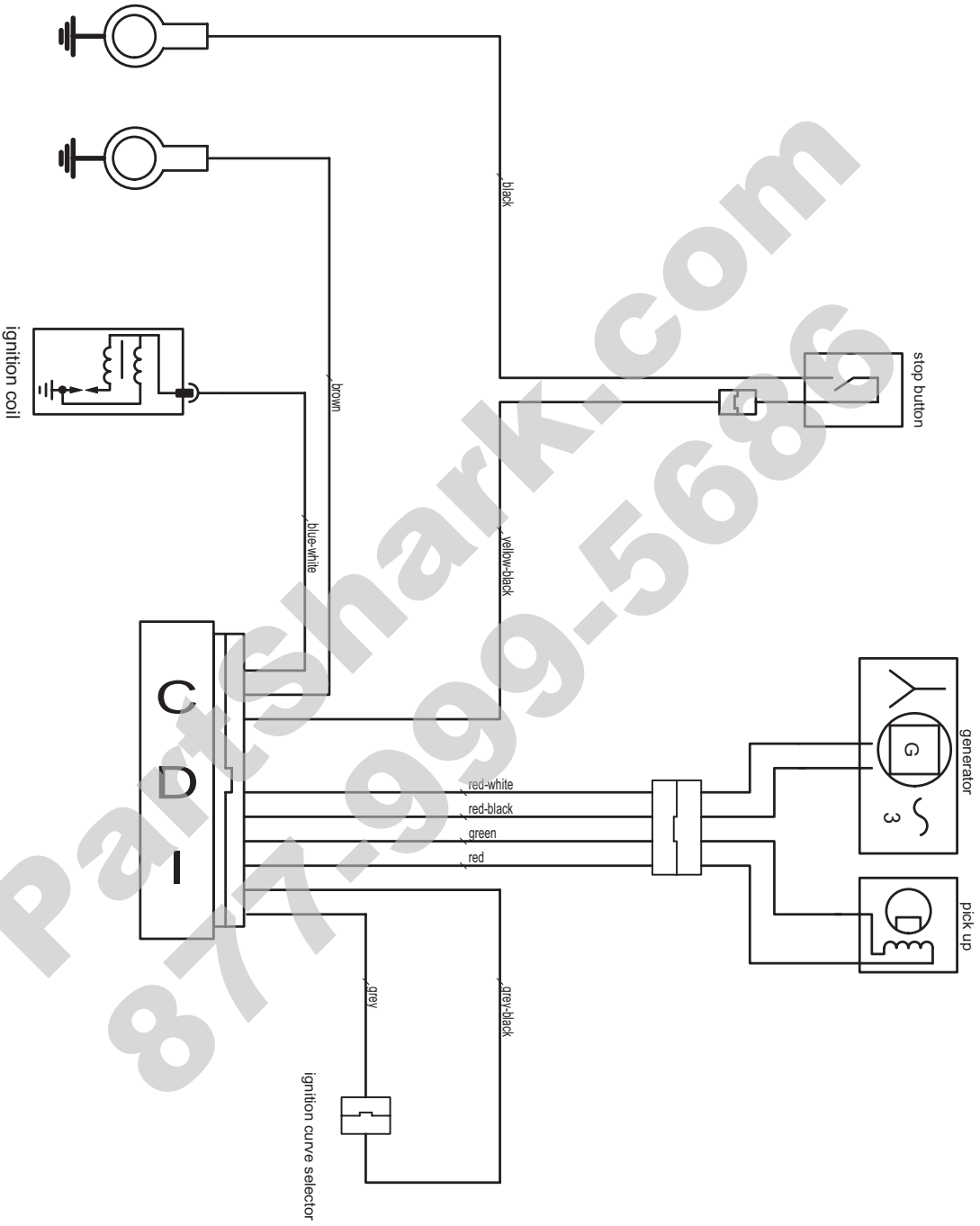





200 XC-W 2007

wiring diagram

main harness

548.11.075.000

10.04.2006

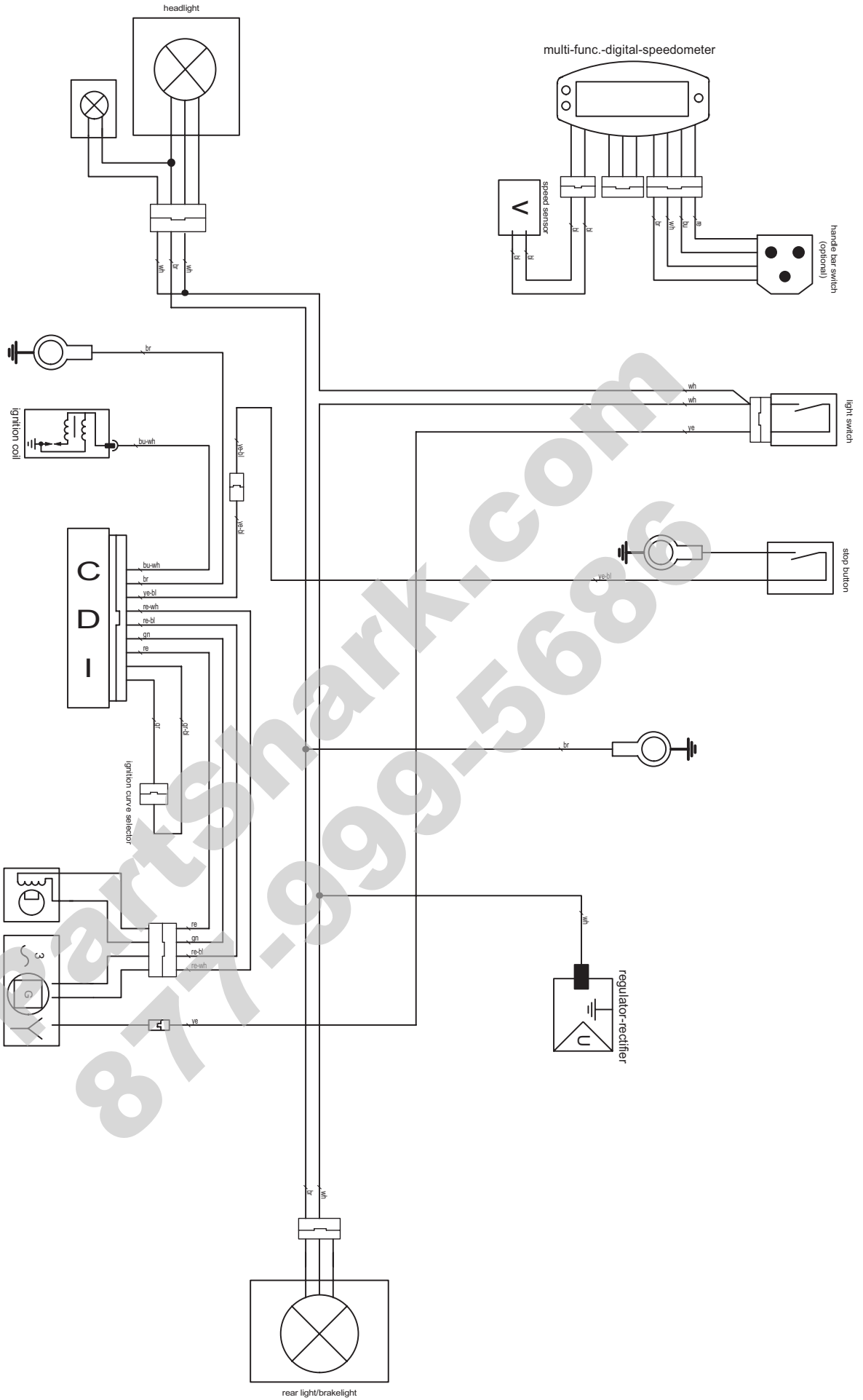



125/144 SX 2008

CDI harness 548.39.032.300

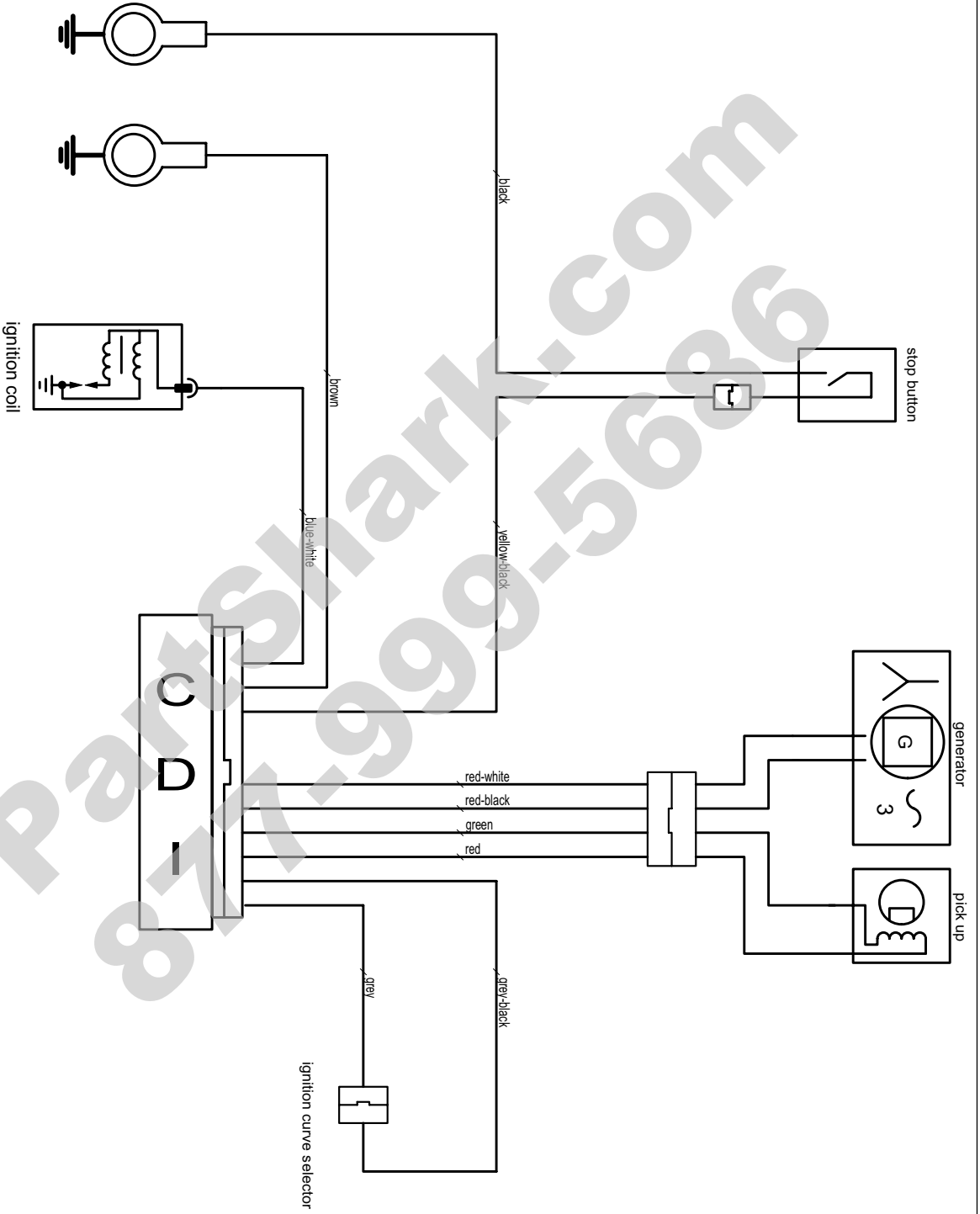



200 XC USA, 200 XC-W USA/ZA 2008

wiring diagram

main harness 548.11.075.100  
CDI harness 548.39.032.300

Art.-Nr. 3.206.062-E

Repair manual KTM 125 / 144 / 150 / 200

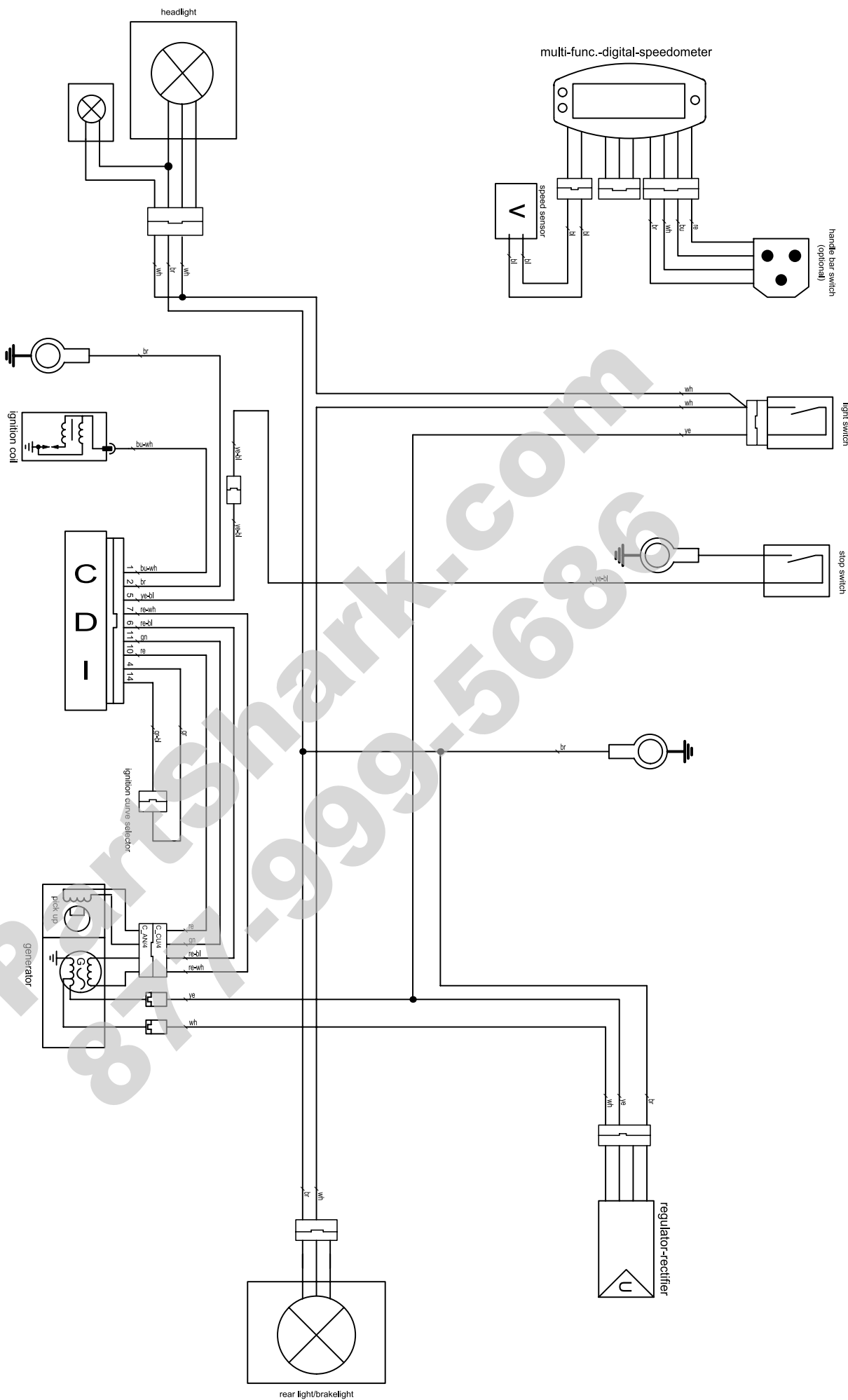



125/200 EXC/EXC SixDays EU/AUS 2008

wiring diagram

main harness 548.11.075.350  
CDI harness 548.39.032.300

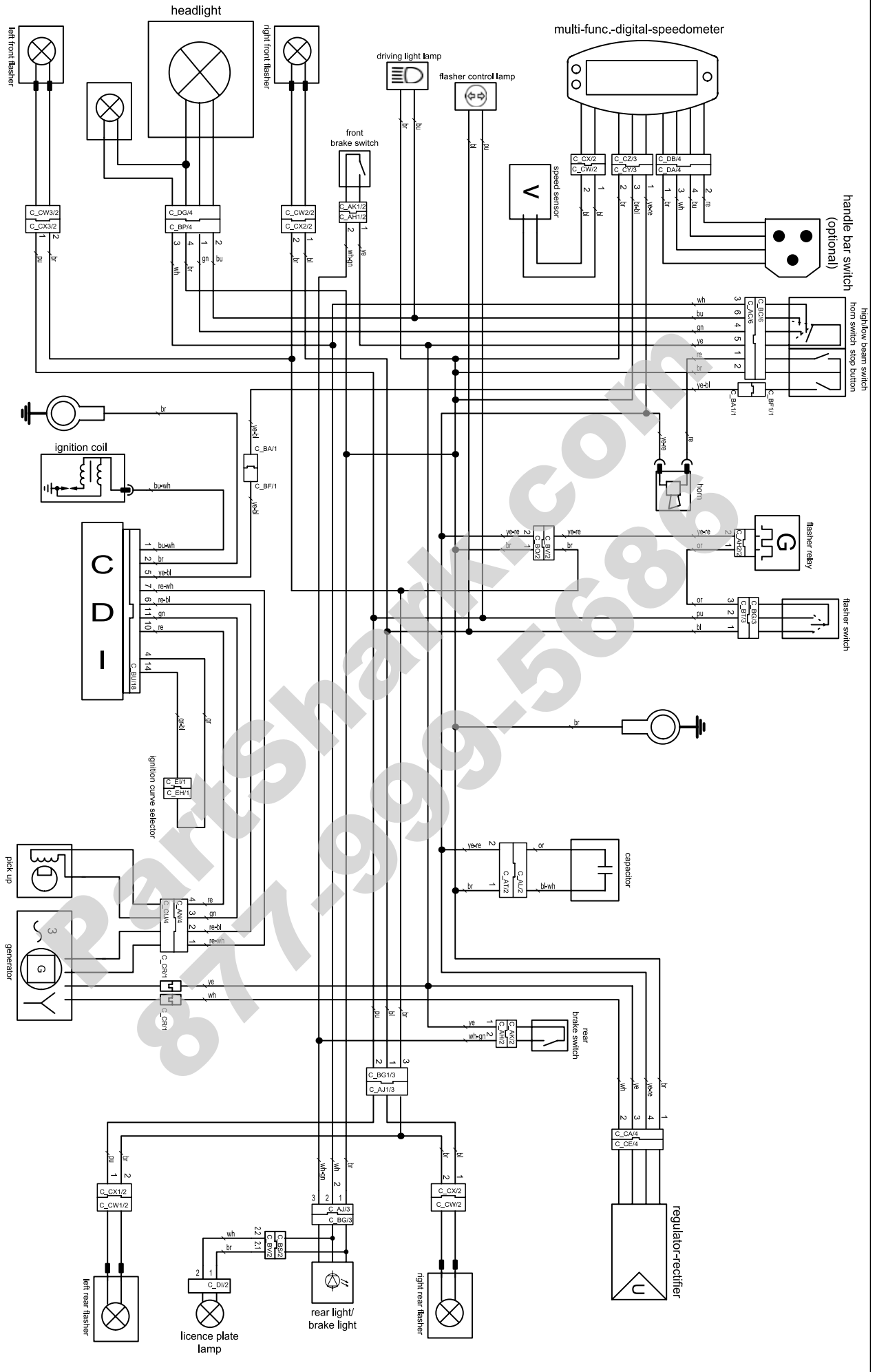



125/150/250 SX 2009

CDI harness 548.39.032.300

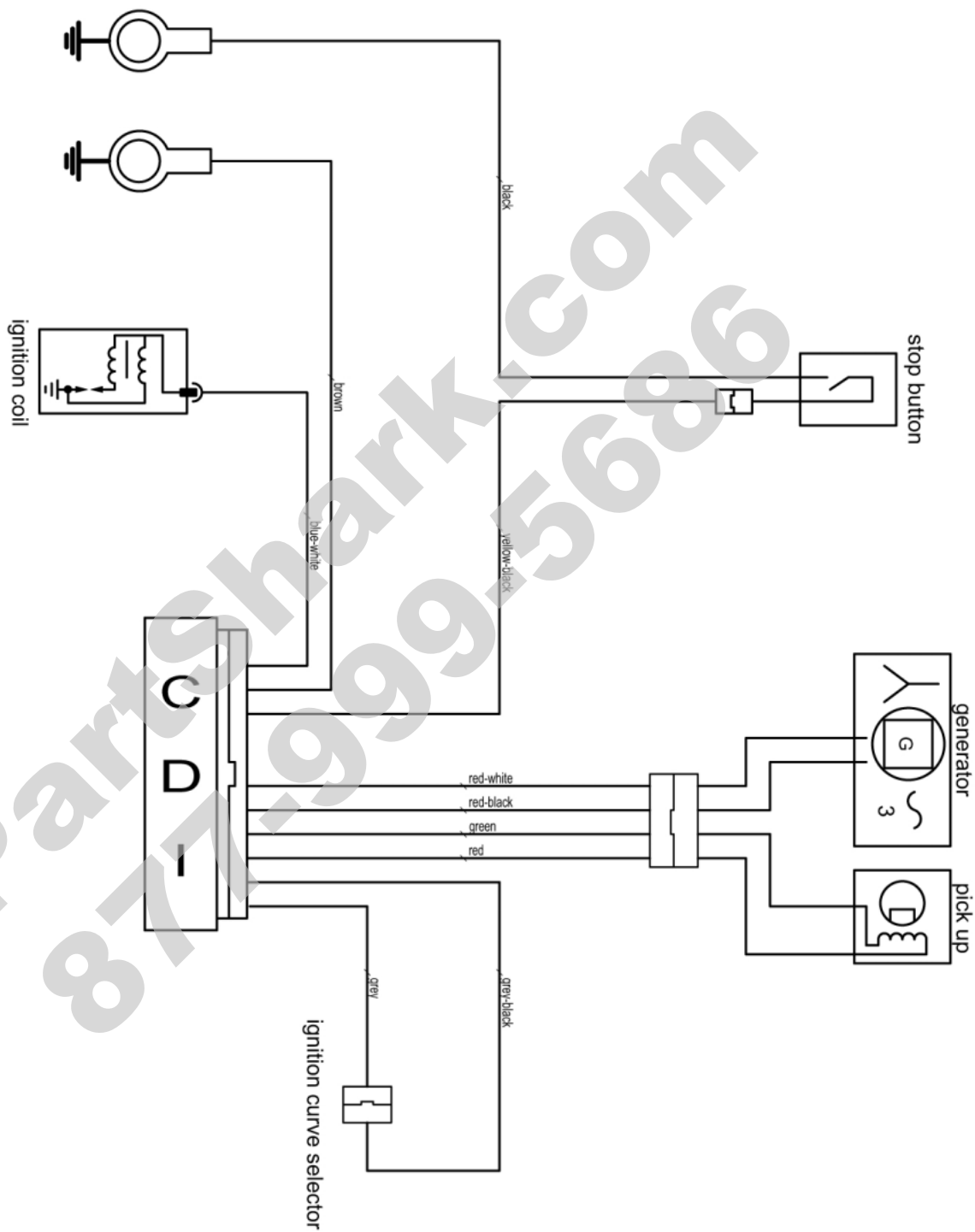



200 XC USA 2009  
 200 XC-W USA 2009  
 200 XC-W ZA 2009

wiring diagramm

main harness 548.11.075.100  
 CDI harness 548.39.032.300

Wiring harness model	Light	Light	Light	Start SW
200 XC USA	X	X	X	
200 XC-W USA	X	X	X	

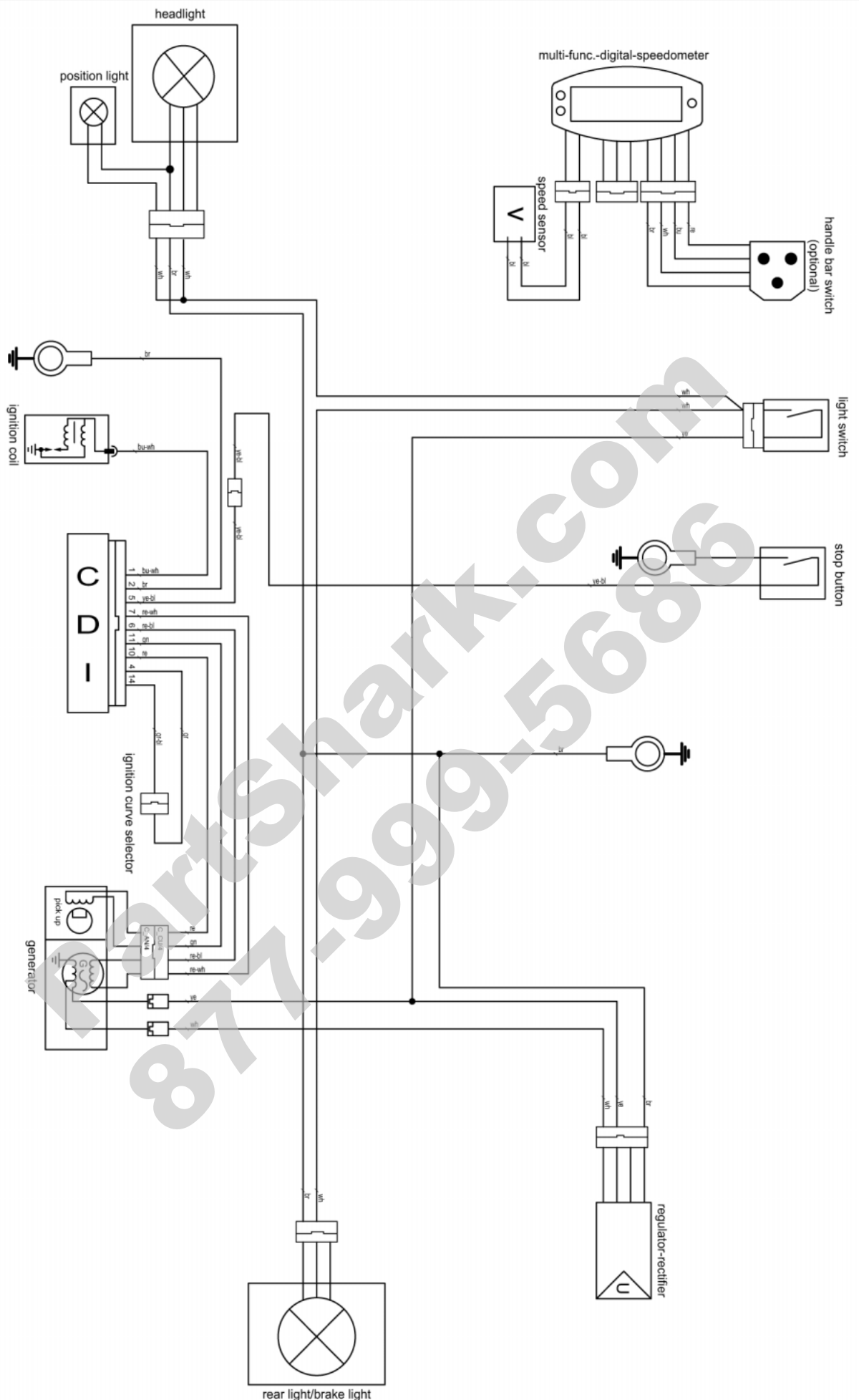

827-995686.com



125/200/250 EXC EU 2009  
125/250 EXC EU/EXC Six Days 2009  
200 EXC AUS 2009

wiring diagram

main harness 548.11.075.350  
CDI harness 548.39.032.300

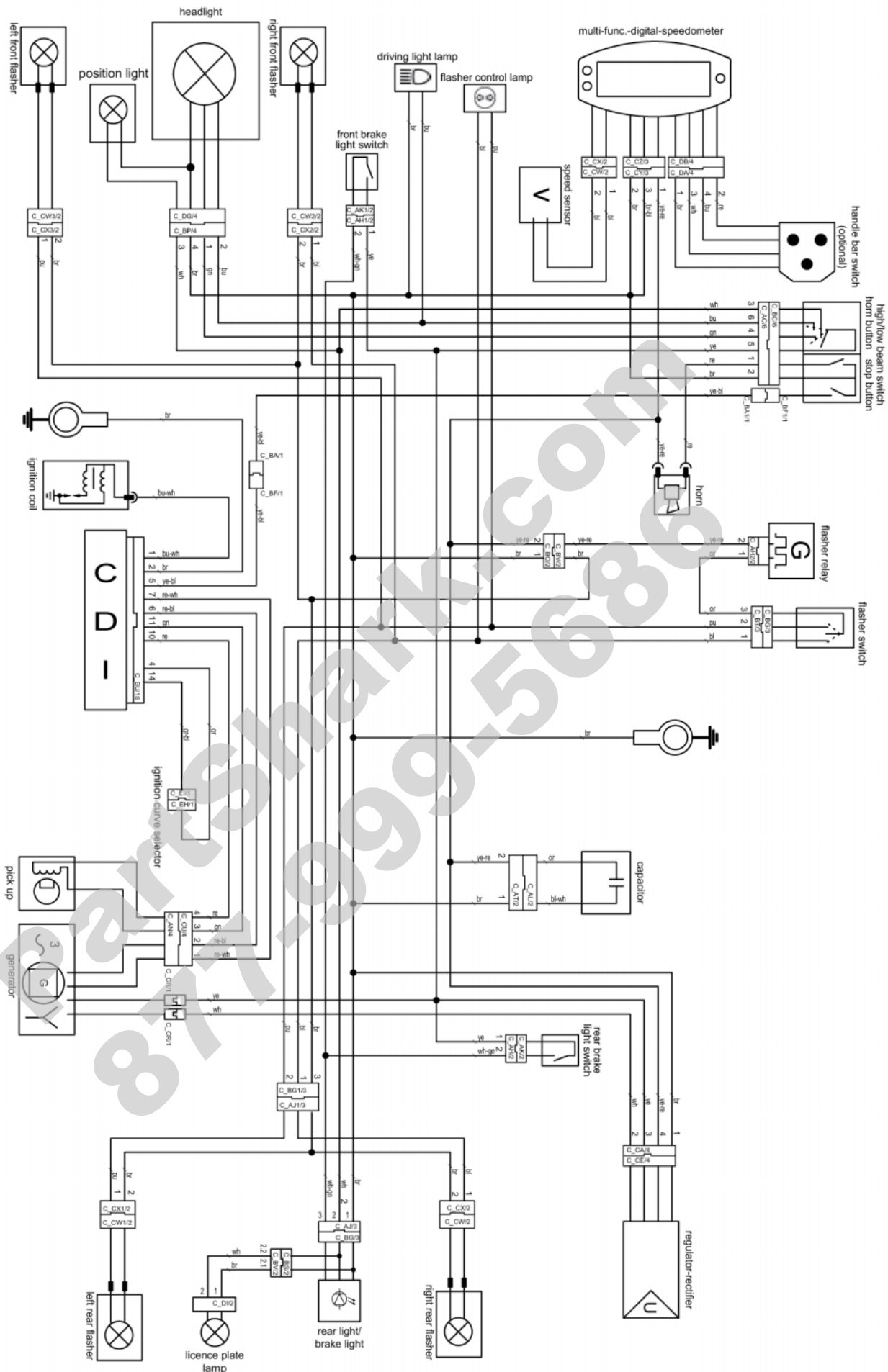

**Cable colours**

bl: black

ye: yellow

bu: blue

gn: green

re: red

wh: white

br: brown

or: orange

pi: pink

gr: grey

pu: purple

PartShark.com  
877-999-5686





125/150 SX 2010

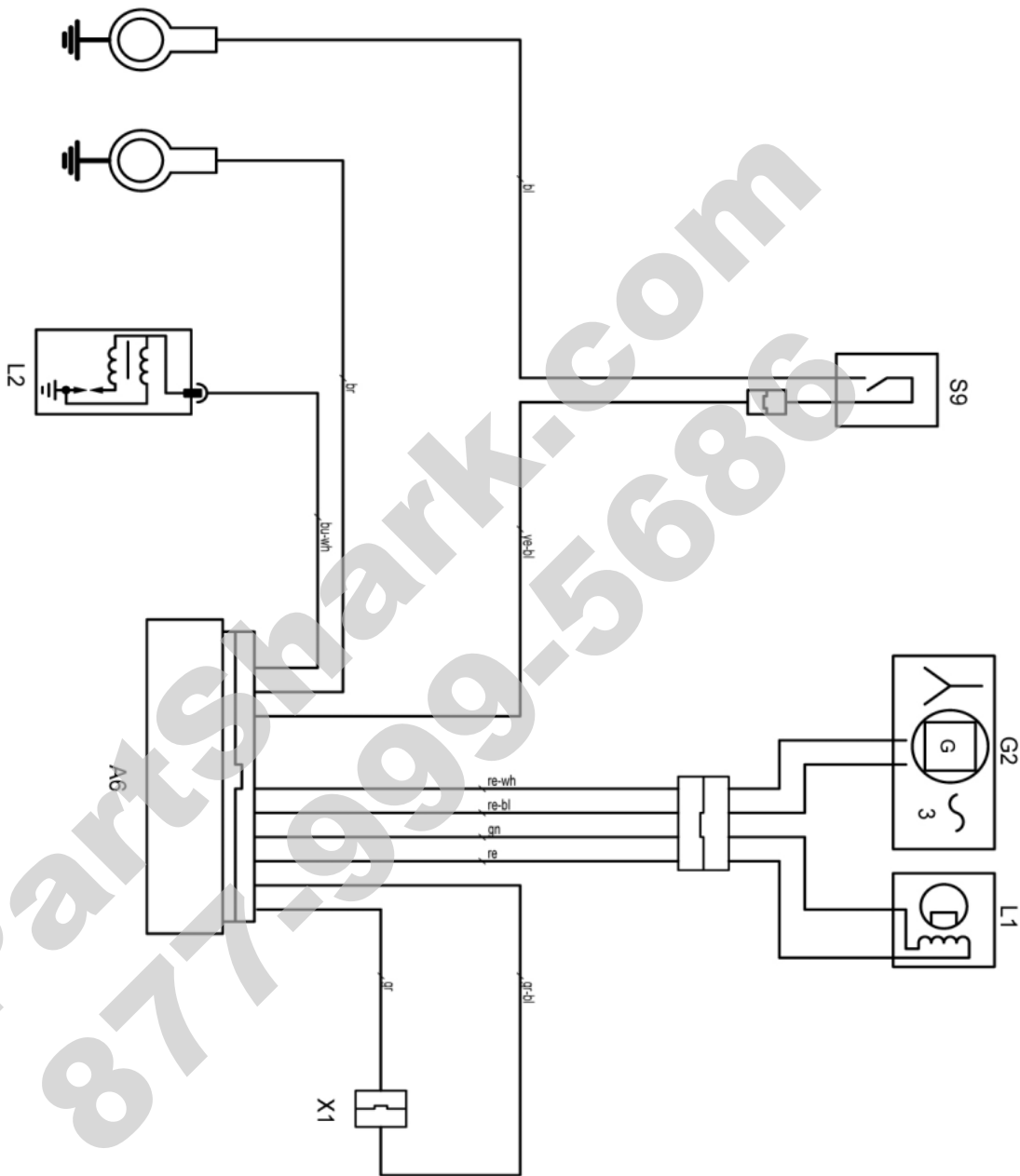

Art.-Nr. 3.206.062-E

Repair manual KTM 125 / 144 / 150 / 200



200 XC USA, 200 XC-W USA 2010

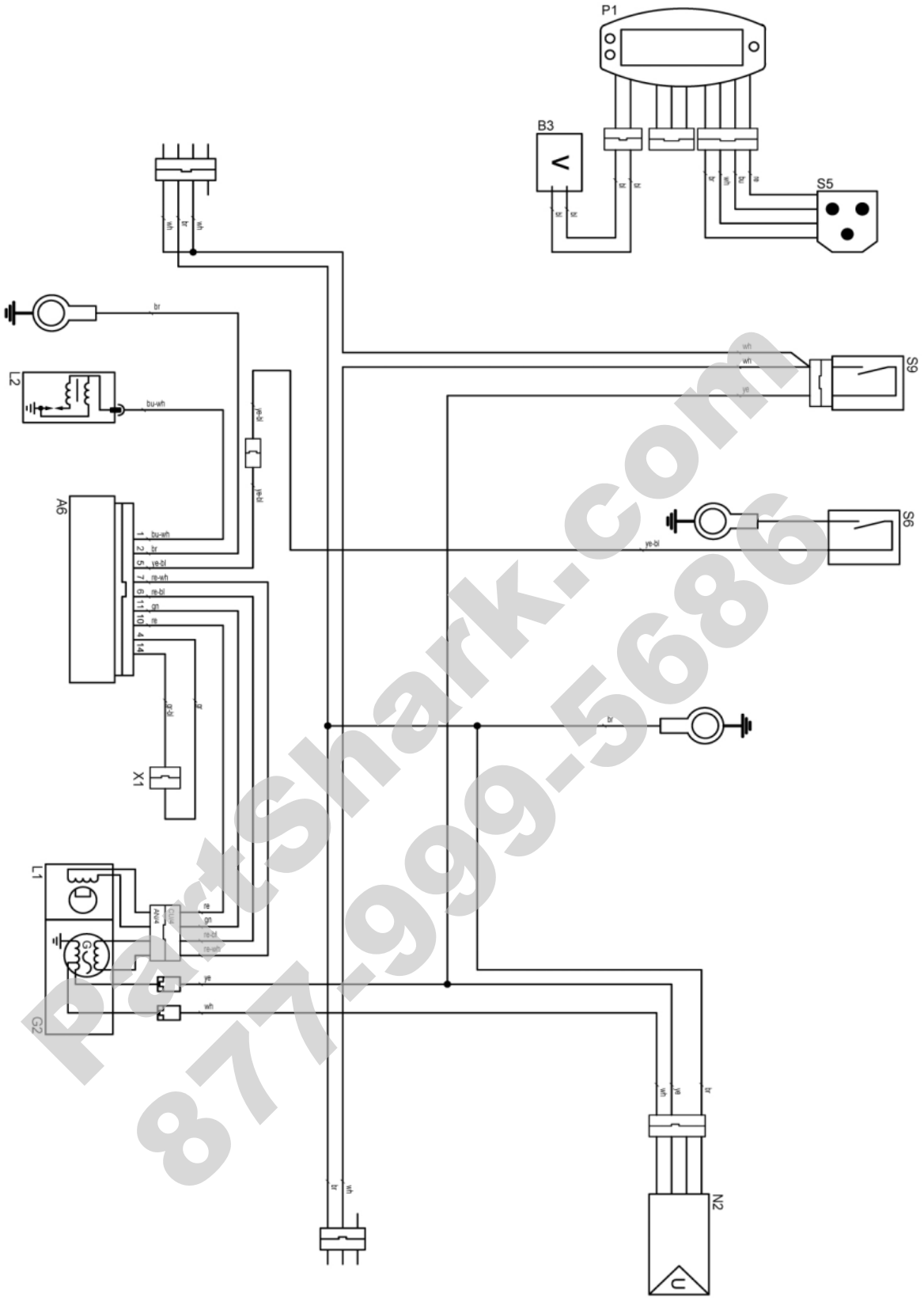



**Components**

A6	CDI controller
B3	Wheel speed sensor
G2	Alternator
H1	Right rear turn signal
H2	Left front turn signal
H3	Left rear turn signal
H4	Right front turn signal
H5	Brake/tail light
H7	Parking light
H9	License plate lamp
H11	Low/high beam
H13	Horn
H15	Turn signal indicator light
H18	High beam indicator light
K1	Starter relay with main fuse
K2	Turn signal relay
L1	Ignition pulse generator
L2	Ignition coil
N2	Voltage regulator/rectifier
P1	Speedometer
S1	Rear brake light switch
S2	Front brake light switch
S5	Tripmaster switch (optional)
S6	Light switch
S7	Horn button, short circuit button
S8	Turn signal switch
S11	Emergency OFF switch (EXC OFF)

**Cable colors**

bl	Black
bl-wh	Black-white
br	Brown
br-bl	Brown-black
bu	Blue
bu-wh	Blue-white
gn	Green
gr	Gray
or	Orange
pu	Violet
re	Red
re-bl	Red-black
re-wh	Red-white
wh	White
wh-gn	White-green
wh-re	White-red
ye	Yellow
ye-bl	Yellow-black
ye-re	Yellow-red